

**CATA
LOG
22**

**JULIUS
BLUM
& CO. INC.**

Juliusblum.com
800.526.6293

Stock Components
for Architectural
Metal Work



B

B

B

B



B

B

B

B

B



B

B

B

B



B

B

B

B

B



B

B

B

B



B

B

B

B

B





CATALOG 22

Villanova University, Mark B. Thompson Associates, LLC, Villanova, PA (Architect), Roy J. Shelton, Inc. (Fabricator), ML Baird & Company (Landscape Architect), Hunter Roberts Construction Group (General Contractor).

Since 1910, Julius Blum & Co., Inc. continues its tradition of excellence and innovation with the release of our latest comprehensive resource of stock components for architectural metal work.

A family business, operating under third and fourth generation leadership, Julius Blum & Co., Inc. has not lost sight of our founder's mission: to best serve our customers with prompt service and in-stock quality components.

In addition to our product descriptions, our Catalog and website contain Engineering Data to aid in the design of structurally sound and code compliant railing systems for various applications.

Additional information, including photographs of finished jobs and products, drawings files, and technical data is available online at juliusblum.com. We look forward to your calls and emails.

IN STOCK FOR PROMPT SHIPMENT

Julius Blum & Co., Inc. is unique in the industry. While most companies choose to maintain minimum stock, we have always had substantial quantities on hand of the items shown in our catalog. We take pride in our prompt service and generally ship within a day or two of receiving an order.

SHIPPING AND PACKAGING

All components are produced and handled with great care and protected for shipment by wrapping and/or crating to assure a product well-suited for architectural metal work.

Aluminum bars, angles, channels and tubing—except for structural shapes—are stocked in mill-wrapped bundles of approximately 100 pounds. Each bundle is paper-interleaved to protect the surface during storage and shipment.

Small package shipments are made via courier service. All other shipments are by common carrier, FOB, Carlstadt NJ.

PROTECTING THE ENVIRONMENT

With a firm belief that we must all do our part to protect the environment, Julius Blum & Co., Inc. has long worked to reduce waste in our daily operations. By using old newspapers as packing material, reusing storage boxes and bins in the warehouse, recycling unused business forms into memo pads, and placing solar panels on the roof of our building, we seek to lessen our impact on our surroundings.

The architectural metals we stock are largely composed of recycled material. We are glad to provide information on the recycled content of our material for those seeking LEED certification.

This brochure is printed on FSC® certified paper. 100% of the electricity used to make the paper is offset with Green-e® certified renewable energy. The paper contains a minimum of 10% post-consumer recovered fiber.



JB® GLASS RAILING COMPONENTS

Features 4
 JB® Glass Railing Components 6
 Wall Brackets 13

TREILLAGE AND ORNAMENTAL RAILINGS PANELS

Features 56
 Treillage and Ornamental Collars 57
 Treillage and Ornamental Railing Panels 58
 Ornamental Panels 64
 Ornamental Panels and Ornaments 65

ELEVATOR CAB COMPONENTS

Features 98
 Elevator Cab Components 99
 Thresholds and Saddles 100
 Door Elevator Saddles and Handrail Mouldings 101
 Handrail Mouldings 102
 Vertical Mounting Brackets 103
 Glass Framing Sections 104

PIPE RAILINGS

Features 14
 Connectorail® System 15
 Post Brackets and Adapters 22
 Wall Brackets 23
 Center Post Brackets 28
 Connectorail® System Installation 25
 Pipe Rail Fittings 28
 OD Tubing and Fittings 31

CARLSTADT® RAILING SYSTEM

Features 67
 Carlstadt® Railing System 67
 Carlsrail® Systems for Non-Welded Assembly 68
 Carlstadt® Post Systems 70
 Carlstadt® Post Brackets 82
 Carlstadt® Wall Brackets and Extensions 83
 Carlstadt® Vertical Mounting Brackets 84
 Carlstadt® Center Post Brackets 86
 Panel Clips 87

DOOR EDGINGS AND VARIOUS MOULDINGS

Door Edgings and Various Mouldings 105

TUBING, BARS AND SHAPES

Features 106
 Aluminum 108
 Steel 114
 Bronze 115
 Nickel-Silver 118
 Stainless Steel 120

TRADITIONAL RAILING COMPONENTS

Features 32
 Handrail Mouldings 34
 Handrail Fittings 39
 Starting Posts 44
 Post and Spindles Fittings 45
 Spindles 46
 Ornamental Spindles and Valance Bars 49
 Bases 50
 Tube Sockets and Flanges 51
 Tubes and Collars 52
 Urn and Ball Finials 53
 Spindle Tops and Cast Rosettes 54
 Ball and Post Caps 55

HANDRAIL BRACKETS

Features 88
 Wall, Post, and Vertical Brackets 89
 Wall Brackets 90
 Wall & Post Bracket for Pipe Railings 91
 Carlstadt® Self-Aligning Wall Brackets 92
 Carlstadt® Self-Aligning Post Brackets 93
 Extensions and Anchors 94
 Carlstadt® Center Post Brackets 95
 Glass Mounting and Vertical Brackets 96
 Vertical Mounting Brackets 97

ENGINEERING DATA AND INDEX

Engineering Data 122
 Product Index 130

Julius Blum & Co., Inc. supplies stock material only and does not offer custom design, fabricating or installation services. It has always been our philosophy never to compete with our customers. As Julius Blum wrote in 1938, "We want our customers to sell our goods at a profit... and for our Iron Master customers to be successful."

If you need help finding a local fabricator, we are always glad to suggest firms in your area that are familiar with our products.

Quality Control

Providing quality material is a tradition at Blum. With very few exceptions, all components are manufactured in the USA. Understanding that the majority of our items are purchased for architectural use, we take care to provide an excellent finish. We have a dedicated staff member whose responsibility includes careful scrutiny of all incoming material. Returns are subject to approval by Julius Blum & Co., Inc.

Finishes

Except as noted, all items shown in our catalog are supplied in a mill finish. Additional polishing, painting or anodizing of these components is not handled by Blum and would be handled by a professional polisher or the metal fabricator. For additional information on this subject, refer to the Metal Finishes Manual published by the National Association of Architectural Metal Manufacturers (www.naamm.org) and the National Ornamental & Miscellaneous Metals Association (www.nomma.org).

Dimensions, weights, and technical data published in this catalog and on our website have been assembled with care but cannot be guaranteed. Details and availability are subject to change. Please call with specific questions.

Nickel-Silver

Julius Blum & Co., Inc. is proud to have reintroduced nickel-silver to the architectural marketplace. When finished, nickel-silver has the appearance of stainless steel with golden highlights. Like bronze, it is a copper alloy which, if left unprotected, will oxidize, although at a much slower rate. Nickel-silver is best cold-worked and may crack when worked at high temperatures. Its chemical composition is 47.7% copper, 40.9% zinc, 7.4% nickel, 2% manganese and 2% lead. Samples are available upon request.

Bronze vs. Brass

One of the constant questions we get is, "What is the difference between bronze and brass?"

Brass and bronze are both copper alloys. In fact, architectural bronze is a sub-classification of brass—sometimes referred to as leaded brass. Blum stocks extrusions in architectural bronze, C38500, exclusively. We stock architectural bronze for several reasons:

1. It has a rich golden color as opposed to brass, which is more yellow.
2. It is more malleable than brass, making it easier to work with.
3. Architectural bronze tubing is extruded with a thicker wall (between .100" and .125" thick) than you will find in brass (usually .062" thick), making it a stronger section and better suited for bending.

All of our cast fittings and brackets are cast in alloy C86500 while our drawn pipe is stocked in alloy C23000—both of these alloys are considered a color match for architectural bronze. Because we exclusively use Architectural Bronze, our cast handrail fittings will not necessarily match with handrail supplied by others.

Fabricating Stainless Steel

Care should be taken when working with stainless steel so as not to contaminate it with ferrous particles. This will occur if the stainless is fabricated using steel or iron tools (i.e. steel files or steel wool). Ferrous particles from steel tools will embed themselves in the stainless steel and will eventually start to rust, which makes it seem that the stainless is rusting. Recovery of the finish is possible with appropriate chemical washes, but proper fabrication will avoid the problem entirely. It is important to note that roll-formed stainless steel handrail shapes require special attention at the joints to assure proper alignment.

Fittings

Julius Blum & Co., Inc. carries a wide range of fittings designed to match with our Connectorail® system and our traditional handrail styles. Due to differences in designs and tolerances, our fittings will not necessarily match with similar handrail and pipe supplied by others. It is important to be aware that differences in tolerances between lengths of handrail moulding and cast fittings require special attention to ensure proper match.

Handrail and Guardrail

Julius Blum & Co., Inc. has always stocked a wide range of handrail mouldings to suit many needs and conditions, but not all Blum handrails are suitable for all applications. Accessibility standards and code authorities often have dimensional limitations on handrail size which eliminate larger handrail mouldings from

consideration. Confirm whether size limitations apply to your installation before specifying.

Most building codes differentiate between handrails and guardrails. Handrails are generally defined as being used for guidance and support, while the purpose of guardrails is to prevent accidental falls. Handrail heights are commonly between 34" and 38", while guardrails are 42" in height.

Guardrails are often required to have an included handrail.

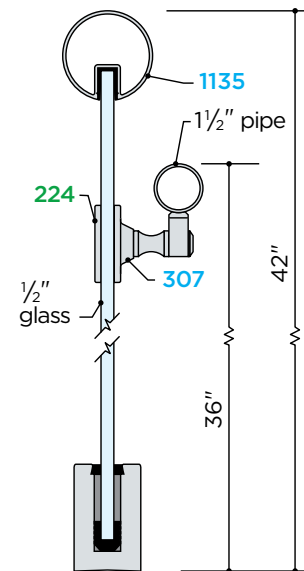

The detail above provides an example of a JB® Glass Railing used as both a guardrail and a handrail. The 3 1/2" cap rail is at a height of 42"—too high and too large for use as a handrail. A 1 1/2" pipe handrail section is mounted at a proper handrail height of 36". As shown, the handrail is mounted using a 307 bracket and a 224 glass mounting adapter kit. The tempered glass must be drilled prior to tempering to permit use of the adapter kit (see page 12 for more information).

Structural Strength and Testing

In recent years, load requirements for handrails and guardrails have increased significantly. It is important to perform the appropriate calculations to determine the suitability of your chosen handrail and support system.

For example, many of our ornamental handrail sections, while well suited for mounting above a picket rail, would tend to exhibit too much vertical deflection when wall mounted at a standard bracket spacing of 4'-0". Bracket spacing would have to be reduced dramatically, or a structural support bar added underneath the handrail, to allow for better bracket spacing.

Blum railing systems have been developed to meet industry standards and code safety requirements when designed in accordance with engineering data and instructions provided in this catalog. Handrail brackets and fascia mountings have been tested thoroughly. Copies of test reports are available upon request.

Construction Codes and Standards

Like all other aspects of building construction, handrails, balusters and guards must conform to various regulatory requirements. Unfortunately, the requirements are not uniform, therefore, they must be verified for the jurisdiction in which a project is located. Generally, in the United States, the following model building codes have been adopted.

International Code Council (ICC)

- International Building Code 2021
- International Residential Code 2021

The model code organizations known as BOCA, ICBO, and SBCCI merged and collaborated to develop a single model building code entitled the International Building Code (IBC), and a separate model code for one- and two-family dwellings and attached single-family dwellings not exceeding three stories entitled the International Residential Code (IRC). The IBC and IRC have gradually replaced the other model building codes in the United States.

Americans with Disabilities Act

In addition to the applicable building code, construction must comply with the requirements of the Americans with Disabilities Act (ADA) and the Architectural Barriers Act (ABA) adopted by Congress. These laws require that all new and certain existing places of public accommodation and commercial facilities be designed and constructed to be accessible to and usable by persons with disabilities.

The Americans with Disabilities Act adopted by Congress in 1992 required circular handrails to be 1 1/4" minimum and 1 1/2" maximum. However, the Guidance on the 2010 ADA Standards for Accessible Design, published by the US Department of Justice, has now properly clarified the intent of the dimensional requirements to be an outside diameter of 1 1/4" to 2".

Americans with Disabilities Act (ADA), 2010 ADA Standards for Accessible Design.

Code Requirements

Building code requirements and safety rules vary from one locality and from one type of structure to another, and are subject to periodic revision. Therefore, it is critical that designers acquaint themselves and comply with the various codes and regulations governing each project.

Handrail Dimensions

At the present time, the following handrail dimensions are specified by the International Building Code, the International Residential Code and the ICC/ANSI A117.1-17 Accessible and Usable Buildings and Facilities.

Circular Cross Section. Handrails shall have a circular cross section with an outside diameter of 1 1/4" (32mm) minimum and 2" (51mm) maximum.

Non-Circular Cross Section. Handrails with other shapes shall be permitted provided they have a perimeter dimension of 4" (100mm) minimum and 6 1/4" (160mm) maximum, and provided their largest cross-section dimension is 2 1/4" (57mm) maximum.

Handrail Clearance

During the past several years the amount of finger clearance required for handrails has been the subject of regulatory discussion. A consensus has emerged on the required clearance, based on the most predominantly enforced codes and standards. The traditional clear space between a wall or other surface and a handrail has been accepted as the most beneficial space by the following codes and standards:

- International Building Code 2021
- International Residential Code 2021
- ICC/ANSI A117.1-17

The Access Board Guidelines

At the present time, the Access Board rules in use are from September 15, 2010. The Access Board website, www.access-board.gov, contains information on the status of each edition and explains where each edition is to be followed and the effective date.

Another current regulatory issue has been finger clearance from handrail brackets. The International Building Code 2021, ICC/ANSI A117.1-17 and the Access Board Guidelines published in the Federal Register on September 15, 2010 all contain requirements for under-handrail clearance similar to those contained in the IBC, as shown below.

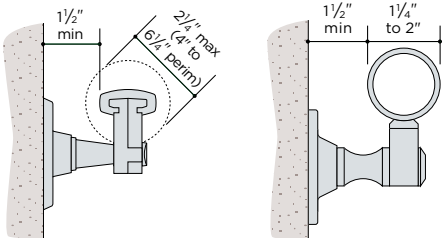

"1014.4 Continuity. Handrail gripping surfaces shall be continuous, without interruption by newel posts or other obstructions.

Exceptions: 3. Handrail brackets or balusters attached to the bottom surface of the handrail that do not project horizontally beyond the sides of the handrail within 1 1/2" (38mm) of the bottom of the handrail shall not be considered obstructions. For each 0.5" (12.7mm) of additional handrail perimeter dimension above 4" (102mm), the vertical clearance dimension of 1 1/2" (38mm) shall be permitted to be reduced by 0.125" (3mm).

The following table illustrates the approximate minimum clearance required from the bottom of a circular handrail with a perimeter of 4" or greater, to a handrail bracket.

| NOMINAL IPS DIAMETER | ACTUAL OUTSIDE DIAMETER |
|----------------------|-------------------------|
| N.A. | 1.25" |
| 1 1/4" | 1.66" |
| 1 1/2" | 1.90" |

| OUTSIDE PERIMETER | CLEARANCE REQUIRED |
|-------------------|--------------------|
| 3.93" | 1 1/4" |
| 5.21" | 1 1/2" |
| 5.97" | 1 5/8" |

Structural Requirements

Structural requirements for handrails, guardrails and grab bars are frequently expressed in two ways: 1) an applied load distributed uniformly along the rail, and, nonconcurrently, 2) a concentrated load applied at any point along the top rail. The designer should consult the governing codes, local ordinance, project specifications and regulatory authorities to determine specific structural requirements. An excellent source of design load requirements can be found in ASCE/ANSI 7-16 Minimum Design Loads for Buildings and Other Structures published by the American Society of Civil Engineers.

The information on this page is intended to be helpful to architects and specifiers. However it is imperative to contact the appropriate local code authority for current information.



© 2025 Julius Blum & Co., Inc.

We dedicate Catalog 22 to Ernie Hulsizer, our vice president for 56 years. Ernie studied metallurgical engineering at Lafayette College and holds an MBA from the Wharton School of Business.

A devoted husband, father, grandfather and great-grandfather and a lifelong Yankee fan, we wish Ernie many years of happy retirement.

JB® GLASS RAILING COMPONENTS

JB® Glass Railing is a system of metal railing components for use with 1/2" or 3/4" tempered glass panels as structural balusters. Matching stock parts speed fabrication and assembly.

Aluminum Shoe Mouldings are designed to support a design load of 300 lbs. applied at any point at the top of a railing up to 42" in height. **Proper mounting of the shoe moulding is crucial to the strength of JB® Glass Railing. Test results are available upon request or from our website, www.juliusblum.com.** Mechanical properties of glass may be verified with supplier of glass panels.

Shoe mouldings are supplied in two configurations and two alloys. Available for 1/2" and 3/4" tempered glass, the heavier sections, in alloy 6063-T52, may be anodized and are better suited for bending and fascia mounting. The lighter section is extruded in high-strength alloy 6061-T6 to provide the required strength with minimum weight. All three sections can be surface mounted—exposed or with a sheet metal trim—or set flush with the floor surface.

Protective Insert prevents direct metal to glass contact and fits closely inside the recess in the handrail mouldings that are mounted to the glass with an adhesive selected at the specifier's discretion.

The setting block supports and cushions the lower edge of the glass while centering it in the channel of the shoe moulding. Glass panels are set in the shoe moulding using a filler selected at the discretion of the architect or fabricator. Do not use epoxy-based fillers.

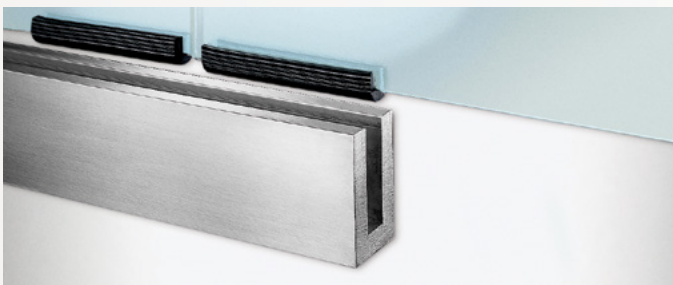

GLASS MOUNTING

Resilient setting blocks support and cushion glass panels as they are inserted into the shoe. Setting blocks should be 4" to 6" long and placed at points 1/4" and 3/4" distance from edge of the length of the panel from each end. Space is allowed for plumbing and setting of glass—choice of filler material is at the discretion of the specifier/fabricator. Spacer blocks, 1/4" thick, should be inserted between adjoining glass panels to prevent glass to glass contact.

For matching wall-mounted or glass-mounted handrails, use Carlstadt® wall brackets with matching tubing sections or JB® Glass Railing sections and concealed, inserted closure.

The glass tempering process requires that all fabrication be completed prior to tempering. Attempts to cut, drill, or grind the edges after tempering are likely to cause breakage.

- **Aluminum** glass rail sections are extruded from alloy 6063-T52 and, when properly fabricated, are suitable for anodizing, including most of the hard-coat anodic processes. Black anodizing may result in inconsistent matches. Consult your anodizer before specifying.
- **Bronze** glass rail sections are extruded from alloy C38500, architectural bronze.
- **Nickel-Silver** extrusions are of alloy C79800. Nickel-silver is a copper alloy, similar in appearance to stainless steel with golden highlights.
- **Stainless Steel** glass rail sections are roll-formed, type 302/304 (18-8). It is important to be aware that connections of roll-formed stainless steel shapes require special attention to assure proper alignment.

Bar stock is sold mill finish except as noted. All items are carried in stock in substantial quantities for prompt shipment.



HANDRAIL ASSEMBLY

A vinyl protective insert protects the top edge of the glass panel and fits closely inside the handrail moulding—a windshield sealer-type clear adhesive is recommended. Intermediate rails may be attached directly to the glass (holes must be drilled before tempering) using the JB® Glass-Mounted Handrail Adapter Kit and Carlstadt® wall brackets. Splice connections for tubular sections are accomplished with internal connector sleeves and structural epoxy.



Center of Theological Inquiry, Princeton, NJ, Capitol Steel Products, Inc., Trenton, NJ (Fabricator), Michael Graves Architect, Princeton, NJ (Architect), © Jeffrey Totaro, 2024 (Photo Credit).

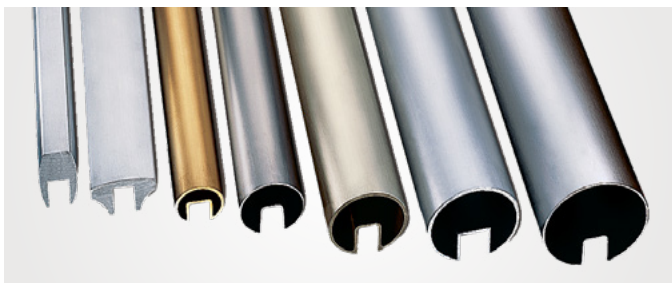

HANDRAILS AND TUBING

JB® Glass Railing top mouldings are available in several shapes and sizes in aluminum, bronze, nickel-silver, stainless steel, and oak acrylic/wood. Handrails may be wall mounted using Carlstadt® brackets with an anchor plug or by using available matching 1.900", 2 1/2", 3", 3 1/2" and 4" tubing. Handrails may be mounted directly to the glass using a JB® Glass-Mounted Handrail Adapter Kit with Carlstadt® wall brackets. Brackets may be mounted on 1/2" or 3/4" tempered glass using a JB® Glass-Mounted Handrail Adapter Kit.

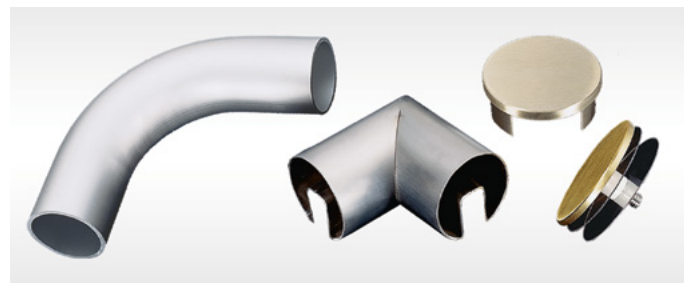

CORNER BENDS, MITER CORNERS, END CAPS

Radius and miter elbows match the contour of 1.900", 2 1/2", 3", 3 1/2", and 4" round tubing shapes. Either style of elbow may be used as a wall return and is attached to handrail by use of internal connector sleeves and structural adhesive. End caps are available for most sections and may be attached by structural adhesive.

SHOE MOULDING

Aluminum, 20' lengths
For use with 1/2" glass, except as noted

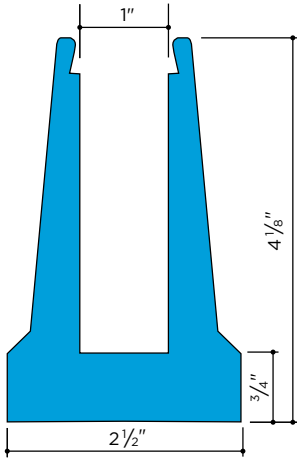

Alloy 6061-T6
● 1141 Aluminum 5.42 lb/ft

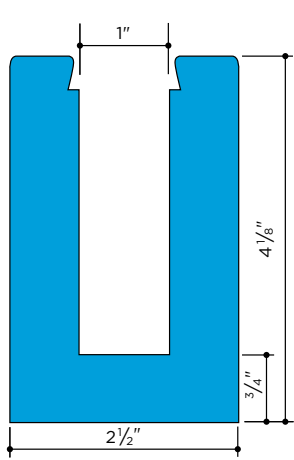

Alloy 6063-T52
● 1142 Aluminum 8.64 lb/ft

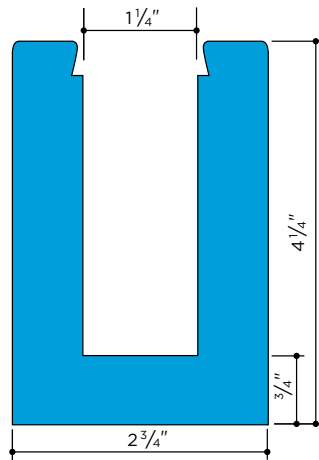

Alloy 6063-T52
● 1143* Aluminum 8.64 lb/ft
* For use with 3/4" glass

SETTING BLOCK

Polyvinyl Chloride

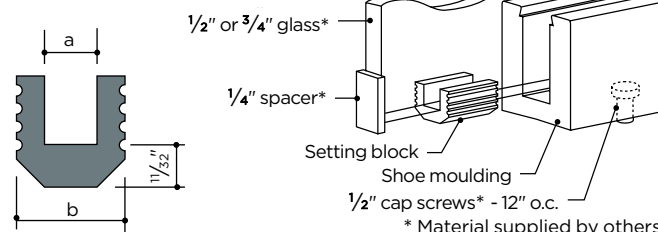

| | a | b | Coil Length |
|--------|------|--------|-------------|
| ● 8711 | 1/2" | 1" | 25' |
| ● 8710 | 3/4" | 1 1/4" | 40' |

SHOE MOUNTING DETAILS

Proper mounting of the shoe moulding is crucial to the strength of JB® Glass Railing. While there are alternate methods of attachment, the assembly details on this page depict the four ways in which the shoe mouldings have been tested.

Assembly Details

Flush Mounted

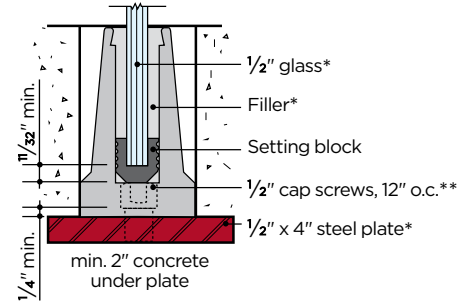

Surface Mounted

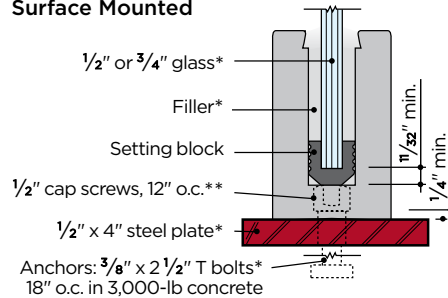

Fascia Mounted

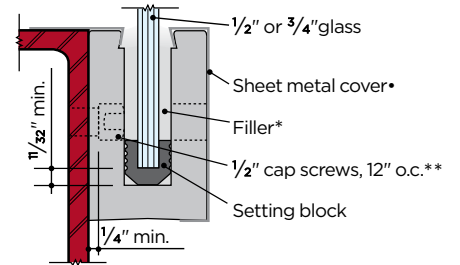

Shelf Angle Mounted

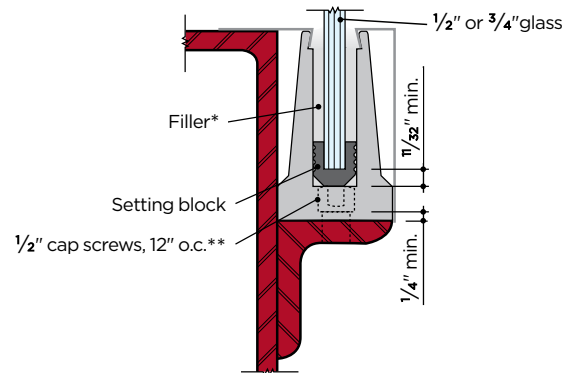

* Material supplied by others
**Mounting Bolt: 1/2" stainless steel socket head cap screw. Used on 12" centers

Aluminum must not be placed in direct contact with concrete or dissimilar metals. Use appropriate paint or primer.
(See Guide Specifications Section 057300 at juliusblum.com)



Center of Theological Inquiry, Princeton, NJ, Capitol Steel Products, Inc., Trenton, NJ (Fabricator), Michael Graves Architect, Princeton, NJ (Architect), © Jeffrey Totaro, 2024 (Photo Credit).

JULIUS BLUM & CO. INC.
 P.O. BOX 986, CARLESTADT, NJ 07072

December 4, 2019

ALUMINUM SHOE MOULDINGS FOR JULIUS BLUM GLASS RAILING TEST REPORT REVIEW

Project Summary

The test program was conducted by Wiss, Janney, Elstner and Associates, Inc. in 1983 for aluminum shoe mouldings 1141 and 1142 for the Julius Blum Glass Railing System. These tests applied a load in 50-lb increments up to maximum concentrated loads of either 400 to 800 pounds depending on the test, with deflection readings taken at each load level. The loads were applied at approximately 42 inches from the reference floor surface. The test sections used were 4 feet in length. Per the 1983 test report, the worst-case deflection in the aluminum shoe moulding under the IBC minimum required 2000 load was 0.039 inches, measured at one half inch from the moulding top. Per the 1983 test report, "no significant dimensional change in the mouldings was observed which would indicate yielding of the material under the test load." Therefore, the Julius Blum 1141 and 1142 aluminium shoe mouldings comply with all current code requirements for railing design. Julius Blum aluminium shoe mouldings are manufactured in the USA. A review of the 1983 Julius Blum Catalog and discussions with Julius Blum representatives have confirmed that the aluminium shoe mouldings tested in 1983 have not been altered in material, dimension or fabrication process. Per the letter dated July 13, 1999 by Estes and Associates, based on its dimensional properties compared with the 1142 moulding, the 1143 aluminium shoe moulding also would be expected to pass the testing. Alfred Benesch and Company has reviewed the test results dated January 13, 1983 (see attached) and as of December 4, 2019 have determined it to be in accordance with the following standards in effect at this time: 2018 IBC, ASTM E894 - 18, and ASTM E935 - 11.

Project Scope

The 1983 testing program evaluated the capability of the aluminum shoe moulding to meet the latest code mandated loadings set forth at the time by OSHA handrailing criteria. The Julius Blum aluminum shoe mouldings provide anchorage at the base of glass panels as a part of the overall glass railing system. The test was conducted by attaching the 4 foot segment of moulding onto a test bed. For the flush and surface mounted tests, the test bed was a section of concrete slab that was supported by timbers at each end and secured to the laboratory floor via anchor bolts. For the fascia mounted tests, the test bed consisted of steel angles which were bolted to the laboratory floor. To allow for testing up to 800 pounds, glass panels were replaced with half inch thick 4"x4" steel panels for this test. Therefore, the deflections in the test may not be used to demonstrate expected deflections of the overall glass handrail system, only the aluminum shoe moulding. Loads were measured using a spring scale for tests 1-4 and a calibrated load cell for all the other tests. Deflections were measured using dial gauges with accuracy to the thousandths of an inch. The test was performed in accordance with ASTM E935, Performance of Permanent Metal Railing Systems and Rails for Buildings. The 1983 testing procedure determined that a minimum of three specimens would be tested for each of the five mounting configurations in accordance with the recommendations of the ASTM specifications.

Section 1607.8.1 of the 2018 IBC requires that handrails and guards be designed to support a concentrated load of 200 pounds, or a 50 pound per foot uniform load. Since the aluminum shoe moulding was tested for a length of 4 feet, the concentrated loading condition governed the testing.

benesch

Julius Blum & Co. Inc. | Aluminum Shoe Mouldings for Julius Blum Glass Railing Test Report Review

STRUCTURAL TEST RESULTS

JB® Glass Rail shoe mouldings were subjected to structural testing by the independent testing lab of Wiss, Janney, Elstner Associates, Inc. of Northbrook, Illinois.

The complete JB® Glass Rail Shoe Moulding test report is available upon request.

Reprinted to the right is the summary, reviewed in 2019 by engineering firm Benesch, of the structural test of the JB® Glass Rail Shoe Moulding.

Complete test report available to download juliusblum.com.

● ALUMINUM ● STAINLESS ● PLASTIC

HANDRAIL MOULDINGS

20' lengths. For use with 1/2" glass, except as noted

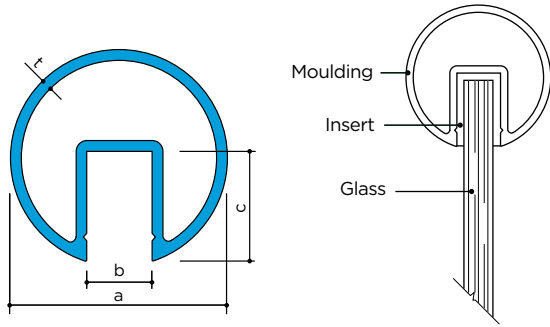

| | | a | b | c | t | lb/ft |
|---------|----------|--------|------|--------|-------|-------|
| ● 1130 | Aluminum | 1.900" | 3/4" | 1 1/4" | .109" | 1.01 |
| ● 1132 | Aluminum | 2 1/2" | 3/4" | 1 1/4" | .125" | 1.52 |
| ● 1137 | Aluminum | 3" | 3/4" | 1 1/4" | .125" | 1.72 |
| ● 1154† | Aluminum | 3" | 1" | 1 1/4" | .125" | 1.73 |
| ● 1135 | Aluminum | 3 1/2" | 3/4" | 1 1/4" | .125" | 1.95 |
| ● 1155† | Aluminum | 3 1/2" | 1" | 1 1/4" | .125" | 1.97 |

† For use with 3/4" glass

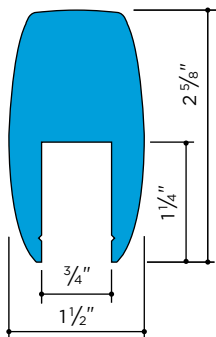

● 1133 Aluminum 3.02 lb/ft

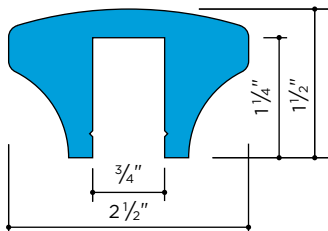

● 1134 Aluminum 2.40 lb/ft

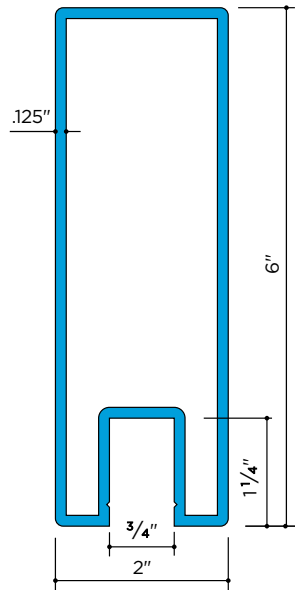

● 1136 Aluminum 2.70 lb/ft

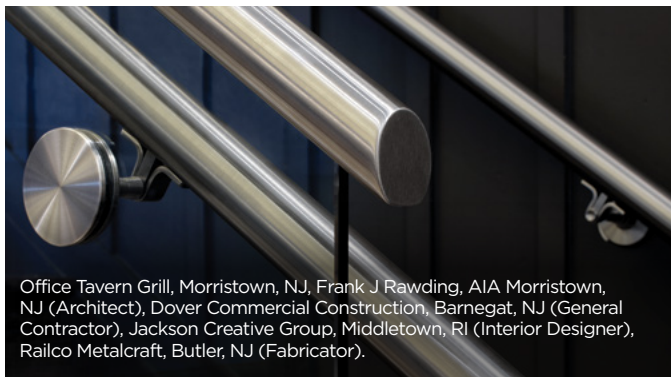

Office Tavern Grill, Morristown, NJ, Frank J Rawding, AIA Morristown, NJ (Architect), Dover Commercial Construction, Barnegat, NJ (General Contractor), Jackson Creative Group, Middletown, RI (Interior Designer), Railco Metalcraft, Butler, NJ (Fabricator).

20' lengths

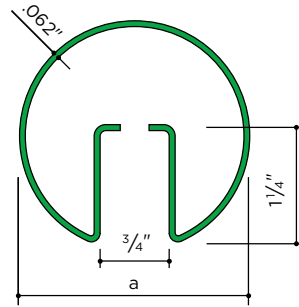

| | | a | lb/ft | Finish |
|---------|-----------|--------|-------|--------|
| ● 1430* | Stainless | 1.900" | 1.70 | No.2B |
| ● 1432* | Stainless | 2 1/2" | 1.96 | No.2B |
| ● 1452 | Stainless | 2 1/2" | 1.96 | No.4 |
| ● 1433* | Stainless | 3" | 2.46 | No.2B |
| ● 1453 | Stainless | 3" | 2.46 | No.4 |
| ● 1472* | Stainless | 4" | 3.17 | No.2B |
| ● 1473 | Stainless | 4" | 3.17 | No.4 |

* Suitable for polishing

It is important to be aware that connections of roll-formed stainless steel shapes require special attention to ensure proper alignment.

PROTECTIVE INSERTS

Polyvinyl Chloride, 7' lengths. Fasten with windshield sealer type of clear adhesive

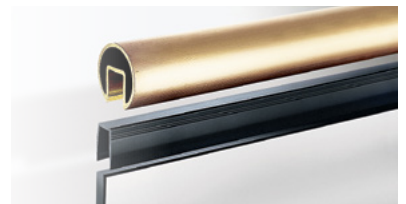
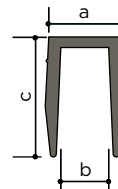

| | | Glass Size | a | b | c |
|--------|--------------------|------------|------|------|--------|
| ● 8709 | Polyvinyl Chloride | 1/2" | 3/4" | 1/2" | 1" |
| ● 8713 | Polyvinyl Chloride | 1/2" | 3/4" | 1/2" | 1 1/8" |
| ● 8714 | Polyvinyl Chloride | 3/4" | 1" | 3/4" | 1 1/4" |

EDGE PROTECTOR

Clear Copolymer, 7' lengths

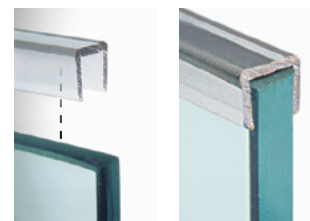
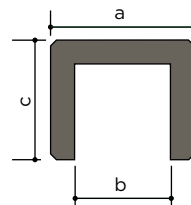

Fasten with windshield sealer type of clear adhesive or clear double-stick foam tape.

| | | Glass Size | a | b | c |
|--------|--|------------|-------|------|------|
| ● 8715 | | 1/2" | .510" | 1/2" | 5/8" |
| ● 8716 | | 3/4" | .760" | 3/4" | 5/8" |

● BRONZE ● NICKEL-SILVER ● PLASTIC

HANDRAIL MOULDINGS

20' lengths, except as noted

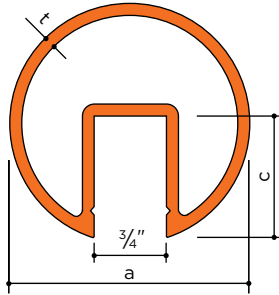

| | | a | c | t | lb/ft |
|----------|--------|--------|--------|-------|-------|
| ● 1230 | Bronze | 1.900" | 3/4" | .100" | 3.43 |
| ● 1233* | Bronze | 3" | 1 1/4" | .125" | 6.05 |
| ● 1235** | Bronze | 3 1/2" | 1 1/4" | .187" | 8.70 |

* 16' lengths ** 12' lengths

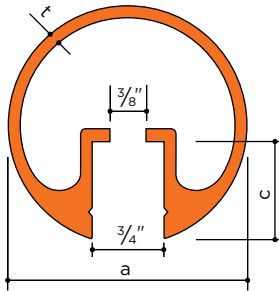

| | | a | c | t | lb/ft |
|--------|--------|--------|----|-------|-------|
| ● 1232 | Bronze | 2 1/2" | 1" | .125" | 5.19 |

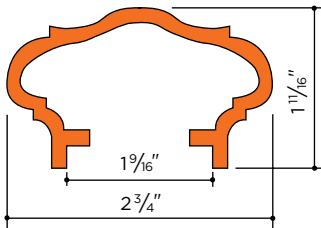

| | | | | | |
|---------|--------|--|--|--|------------|
| ● 4538* | Bronze | | | | 3.15 lb/ft |
|---------|--------|--|--|--|------------|

* 16' lengths Use with 8738 insert for 1/2" glass

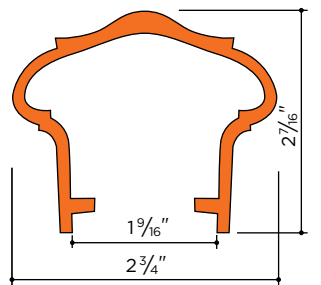

| | | | | | |
|---------|--------|--|--|--|------------|
| ● 4533* | Bronze | | | | 3.66 lb/ft |
|---------|--------|--|--|--|------------|

* 16' lengths; Use with 8738 insert for 1/2" glass

16' lengths, except as noted

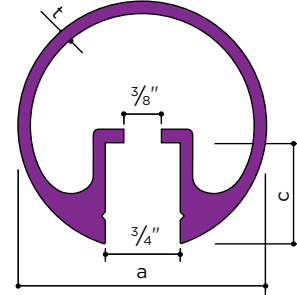

| | | a | c | t | lb/ft |
|--------|---------------|--------|------|-------|-------|
| ● 1330 | Nickel-Silver | 1.900" | 3/4" | .125" | 3.43 |
| ● 1332 | Nickel-Silver | 2 1/2" | 1" | .125" | 5.19 |

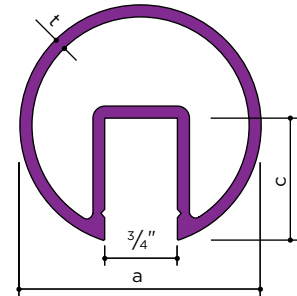

| | | a | c | t | lb/ft |
|--------|---------------|----|--------|-------|-------|
| ● 1333 | Nickel-Silver | 3" | 1 1/4" | .125" | 5.28 |

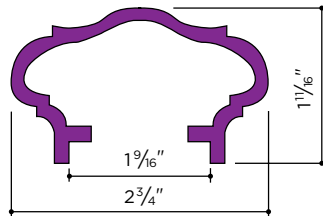

| | | | | | |
|---------|---------------|--|--|--|------------|
| ● 5538* | Nickel-Silver | | | | 2.96 lb/ft |
|---------|---------------|--|--|--|------------|

* 20' lengths; Use with 8738 insert for 1/2" glass

PROTECTIVE INSERTS

Polyvinyl Chloride
7' lengths.
Fasten with windshield sealer type of clear adhesive

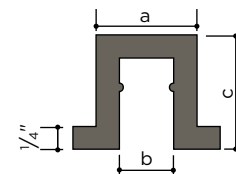
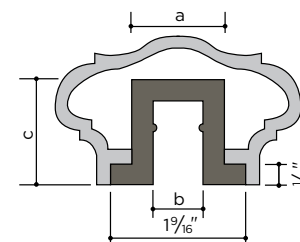

5538 or 4538 with 8738 insert used with 6121 moulding (see pg. 105) on 1/2" glass

| | a | b | c |
|--------|----|------|--------|
| ● 8738 | 1" | 1/2" | 1 1/4" |

● ALUMINUM ● BRONZE ● NICKEL-SILVER ● STAINLESS



Private Residence, Connecticut, Architectural Atlantic Stair NY, Inc. Brooklyn, NY (Fabricator), Tanner White Architects, Westport, CT (Architect), Asprea Studio, New York, NY/ Miami, FL (Designer) Quest Builders Group, NY, NY, Milford, CT, Miami, FL, Oakland, CA (Builder).

END CAPS

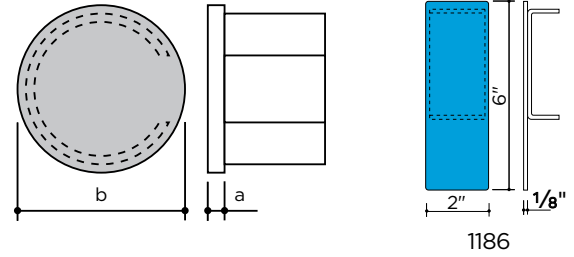

| | | a | b |
|----------|---------------|------|--------|
| ● 7280 | Aluminum | 1/8" | 1.900" |
| ● 1180 | Aluminum | 1/8" | 2 1/2" |
| ● 1182 | Aluminum | 1/8" | 3" |
| ● 1181 | Aluminum | 1/8" | 3 1/2" |
| ● 1186 • | Aluminum | 1/4" | 2" |
| ● 1282 | Bronze | 1/4" | 1.900" |
| ● 1280 | Bronze | 1/4" | 2 1/2" |
| ● 1283 | Bronze | 1/4" | 3" |
| ● 1281 | Bronze | 1/4" | 3 1/2" |
| ● 4538N | Bronze | 2" | • |
| ● 1330N | Nickel-Silver | 1/4" | 1.900" |
| ● 1332N | Nickel-Silver | 1/4" | 2 1/2" |
| ● 1333N | Nickel-Silver | 1/4" | 3" |
| ● 5538N | Nickel-Silver | 2" | • |
| ● 9380 | Stainless | 1/8" | 1.900" |
| ● 1480 | Stainless | 1/8" | 2 1/2" |
| ● 1482 | Stainless | 1/8" | 3" |
| ● 1473N | Stainless | 1/8" | 4" |

• Matches profile

FITTINGS AVAILABILITY FOR JB® GLASS RAILING

| Handrail Moulding | 90° Radius Elbow | 90° Miter Elbow | Connector Sleeve | End Cap | Matching Tubing |
|-------------------|------------------|-----------------|------------------|-----------|-----------------|
| ● 1130 | ● 7210 | | ● 1160 | ● 7280 | ● Yes |
| ● 1132 | ● 1110 | ● 1111 | ● 1163 | ● 1180 | ● Yes |
| ● 1135 | ● 1122 | ● 1112 | ● 1164 | ● 1181 | ● Yes |
| ● 1136 | | | | ● 1186 | ● Yes |
| ● 1137 | ● 1120 | ● 1115 | ● 1170 | ● 1182 | ● Yes |
| ● 1154 | ● 1120 | ● 1113 | ● 1170 | ● 1182 | ● Yes |
| ● 1155 | ● 1122 | ● 1114 | ● 1164 | ● 1181 | ● Yes |
| ● 1230 | ● 1222 | ● 1214† | ● 1160 | ● 1282† | ● Yes |
| ● 1232 | ● 1210 | ● 1211† | ● 1163 | ● 1280† | ● Yes |
| ● 1233 | ● 1220 | ● 1213† | ● 1170 | ● 1283† | ● Yes |
| ● 1235 | | ● 1212† | ● 1264 | ● 1281† | ● Yes |
| ● 1330 | ● 1330C | | ● 1363 | ● 1330N† | ● Yes |
| ● 1332 | ● 1332C | | ● 1163 | ● 1332N† | ● Yes |
| ● 1333 | ● 1333C | | ● 1170 | ● 1333N† | ● Yes |
| ● 1430 | ● 9310** | ● 1414** | ● 9363 | ● 9380** | ● Yes |
| ● 1432/52 | ● 1410* | ● 1411** | ● 1463 | ● 1480** | ● Yes |
| ● 1433/53 | ● 1420* | ● 1413** | ● 1464 | ● 1482** | ● Yes |
| ● 1472/73 | | ● 1473M** | ● 1474 | ● 1473N** | ● Yes |
| ● 4538 | | | | ● 4538N† | |
| ● 5538 | | | | ● 5538N† | |

* No. 2B Finish ** No. 4 Finish

† Polished and lacquered, 180 grit • Matches profile

90° RADIUS ELBOW

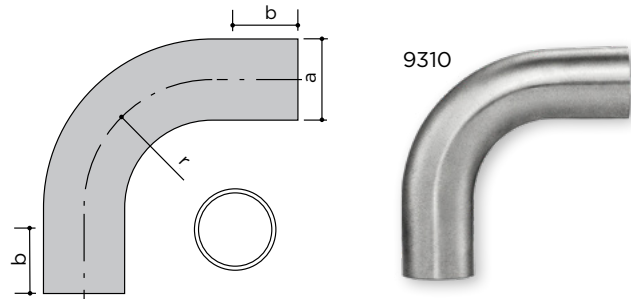

| | | a | r | Wall | b |
|---------|---------------|--------|----|-------|--------|
| ● 7210 | Aluminum | 1.900" | 3" | .109" | 2" |
| ● 1110 | Aluminum | 2 1/2" | 5" | .125" | 2 1/2" |
| ● 1120 | Aluminum | 3" | 5" | .125" | 2 1/2" |
| ● 1122 | Aluminum | 3 1/2" | 5" | .125" | 2 1/2" |
| ● 1222 | Bronze | 1.900" | 3" | .100" | 2 1/2" |
| ● 1210 | Bronze | 2 1/2" | 5" | .125" | 2 1/2" |
| ● 1220 | Bronze | 3" | 6" | .125" | 2 1/2" |
| ● 1330C | Nickel-Silver | 1.900" | 3" | .109" | 2 1/2" |
| ● 1332C | Nickel-Silver | 2 1/2" | 5" | .125" | 2 1/2" |
| ● 1333C | Nickel-Silver | 3" | 5" | .125" | 2 1/2" |
| ● 9310 | Stainless | 1.900" | 3" | .062" | 2" |
| ● 1410 | Stainless | 2 1/2" | 5" | .062" | 2 1/2" |
| ● 1420 | Stainless | 3" | 5" | .062" | 2 1/2" |

● ALUMINUM ● BRONZE ● NICKEL-SILVER ● STAINLESS

90° MITER ELBOW

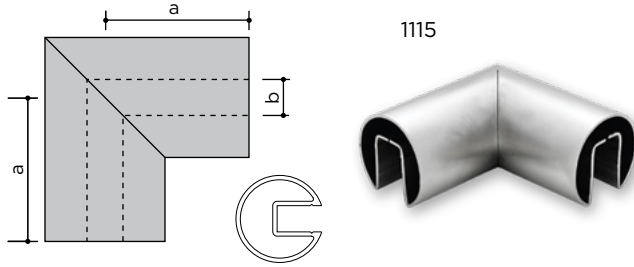

| | | OD | Wall | a | b |
|---------|-----------|--------|-------|--------|------|
| ● 1111 | Aluminum | 2 1/2" | .125" | 3" | 3/4" |
| ● 1115 | Aluminum | 3" | .125" | 4 1/2" | 3/4" |
| ● 1113 | Aluminum | 3" | .125" | 4 1/2" | 1" |
| ● 1112 | Aluminum | 3 1/2" | .125" | 4 1/2" | 3/4" |
| ● 1114 | Aluminum | 3 1/2" | .125" | 4 1/2" | 1" |
| ● 1214 | Bronze | 1.900" | .100" | 3" | 3/4" |
| ● 1211 | Bronze | 2 1/2" | .125" | 3" | 3/4" |
| ● 1213 | Bronze | 3" | .125" | 4 1/2" | 3/4" |
| ● 1212 | Bronze | 3 1/2" | .187" | 4 1/2" | 3/4" |
| ● 1414 | Stainless | 1.900" | .062" | 3" | 3/4" |
| ● 1411 | Stainless | 2 1/2" | .062" | 3" | 3/4" |
| ● 1413 | Stainless | 3" | .062" | 4 1/2" | 3/4" |
| ● 1473M | Stainless | 4" | .062" | 4 1/2" | 3/4" |

OD ROUND TUBING

Mill finish only, except as noted .
20' lengths, except as noted

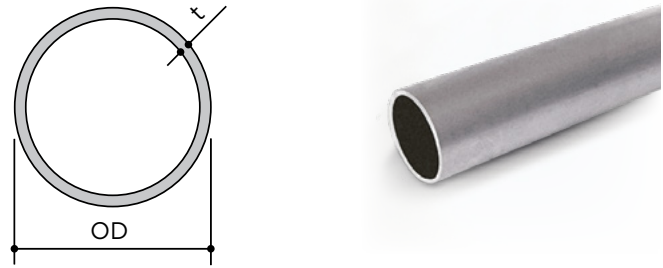

| | |
|-----------------|----------|
| ● Aluminum | 6063-T52 |
| ● Bronze | C38500 |
| ● Nickel-Silver | C79800 |
| ● Stainless | Type 304 |

| | OD | t | lb/ft | Area | l | s |
|------------------|--------|-------|-------|-------|-------|-------|
| ● Aluminum | 1.900" | .109" | .721 | .614 | .247 | .260 |
| ● Aluminum | 2 1/2" | .125" | 1.119 | .933 | .659 | .527 |
| ● Aluminum | 3" | .125" | 1.328 | 1.129 | 1.169 | .779 |
| ● Aluminum | 3 1/2" | .125" | 1.559 | 1.325 | 1.890 | 1.080 |
| ● Bronze | 1.900" | .100" | 2.070 | .565 | .230 | .242 |
| ● Bronze | 2 1/2" | .125" | 3.441 | .933 | .659 | .527 |
| ● Bronze | 3" | .125" | 4.500 | 1.129 | 1.169 | .779 |
| ● Bronze†† | 3 1/2" | .125" | 4.850 | 1.325 | 1.890 | 1.080 |
| ● Nickel-Silver | 1.900" | .109" | 2.250 | .614 | .247 | .260 |
| ● Nickel-Silver† | 2 1/2" | .125" | 3.400 | .933 | .659 | .527 |
| ● Nickel-Silver† | 3" | .125" | 4.500 | 1.129 | 1.169 | .779 |
| ● Stainless** | 1.900" | .062" | 1.274 | .375 | .158 | .166 |
| ● Stainless | 2 1/2" | .062" | 1.691 | .479 | .356 | .285 |
| ● Stainless | 3" | .062" | 1.930 | .577 | .622 | .415 |
| ● Stainless | 4" | .062" | 2.550 | .804 | 1.556 | .778 |

** No. 4 Finish † 16' lengths †† 12' lengths

CONNECTOR SLEEVE

5" lengths

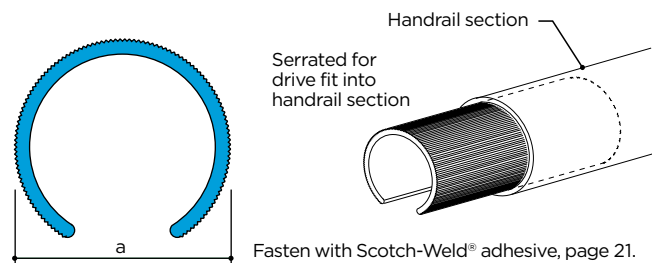

| | | a |
|--------|--------------------------------------------------|--------|
| ● 7063 | Aluminum for 6489 Bronze and 5289 Nickel-Silver | 1.500" |
| ● 1363 | Aluminum for 1330 handrail | 1.650" |
| ● 1160 | Aluminum for 1130 and 1230 handrails | 1.682" |
| ● 9363 | Aluminum for 1430 handrail | 1.770" |
| ● 1163 | Aluminum for 1132, 1232, and 1332 handrails | 2.250" |
| ● 1463 | Aluminum for 1432 and 1452 handrails | 2.375" |
| ● 1170 | Aluminum for 1137, 1154, 1233 and 1333 handrails | 2.750" |
| ● 1464 | Aluminum for 1433 and 1453 handrails | 2.875" |
| ● 1264 | Aluminum for 1235 handrail | 3.125" |
| ● 1164 | Aluminum for 1135 and 1155 handrails | 3.250" |
| ● 1474 | Aluminum for 1472 and 1473 handrails | 3.875" |

COVER FLANGE

Satin Finish

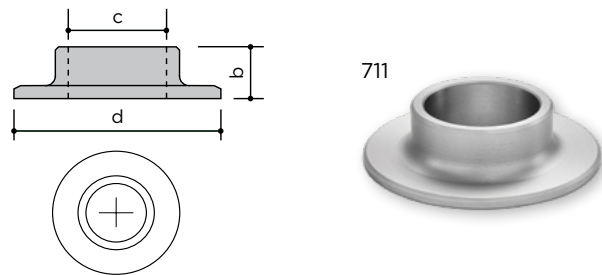

| | | OD | b | c | d |
|--------|---------------|--------|---------|-------|--------|
| ● 711 | Aluminum | 1.900" | 1" | 1.94" | 4" |
| ● 1125 | Aluminum | 2 1/2" | 1" | 2.54" | 4 3/4" |
| ● 1123 | Aluminum | 3" | 1" | 3.04" | 5" |
| ● 811 | Bronze | 1.900" | 1" | 1.94" | 4" |
| ● 1225 | Bronze | 2 1/2" | 1" | 2.54" | 4 3/4" |
| ● 1223 | Bronze | 3" | 1" | 3.04" | 5" |
| ● 411 | Nickel-Silver | 1.900" | 1" | 1.94" | 4" |
| ● 1325 | Nickel-Silver | 2 1/2" | 1" | 2.54" | 4 3/4" |
| ● 1323 | Nickel-Silver | 3" | 1" | 3.04" | 5" |
| ● 211 | Stainless | 1.900" | 7/8" | 1.94" | 4 1/2" |
| ● 1425 | Stainless | 2 1/2" | 1 1/16" | 2.54" | 4 7/8" |
| ● 1423 | Stainless | 3" | 1 7/16" | 3.04" | 6 1/8" |

● ALUMINUM ● BRONZE ● NICKEL-SILVER ● STAINLESS

WALL-MOUNTED HANDRAIL

Matching tubing sections are available for wall mount using Carlstadt® rail wall brackets. JB® Glass Rail sections may also be wall mounted using the appropriate hardware. An anchor plug slips into the recess of the handrail and is locked in place by the bracket mounting screws. The handrail bracket flange is concealed inside the recess of the handrail. The underside of the handrail may be closed with an aluminum closure or stainless flat.

CLOSURES

5' lengths, Flat

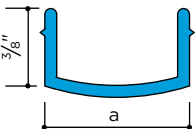

| | a | lb/ft |
|-----------------|------|-------|
| ● 1138 Aluminum | 3/4" | .10 |
| ● 1139 Aluminum | 1" | .13 |

For use with aluminum, nickel-silver and bronze handrails

TRUE BAR

12' to 14' lengths, sharp corners

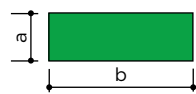

| | a | b | lb/ft |
|-------------|-------|------|-------|
| ● Stainless | 3/16" | 3/4" | .48 |

For use with stainless steel handrails

ANCHOR PLUG

Fits recess in handrail

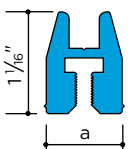

| | a |
|-----------------|------|
| ● 1162 Aluminum | 3/4" |
| ● 1161 Aluminum | 1" |

Bottom of anchor plug has continuous thread for #10-32 screw

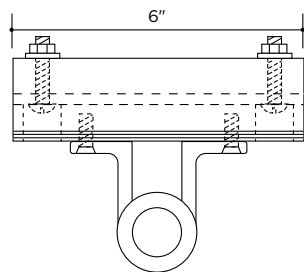
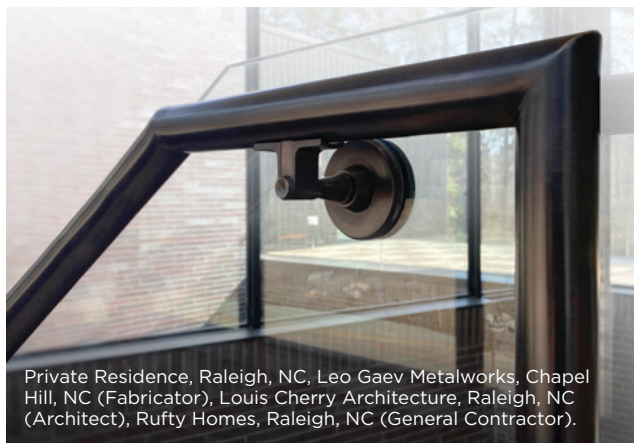

GLASS-MOUNTED HANDRAIL

Handrail may be mounted to the face of the tempered glass balustrade using a combination of wall brackets and our JB® Glass-Mounted Handrail Adapter Kit. The kit contains a disc with a 3/8" stud weld, a bushing, and two gaskets.

TO ASSEMBLE:

1. Prior to tempering, for 1/2" glass drill a 5/8" clear hole; for 3/4" glass drill a 7/8" clear hole.
(Do not attempt to drill a hole in tempered glass—it will most likely break).
2. Insert the bushing in the hole.
3. Insert the stud welded disc with gasket through the bushing; place the gasket on the other side.
4. Thread on bracket and tighten.

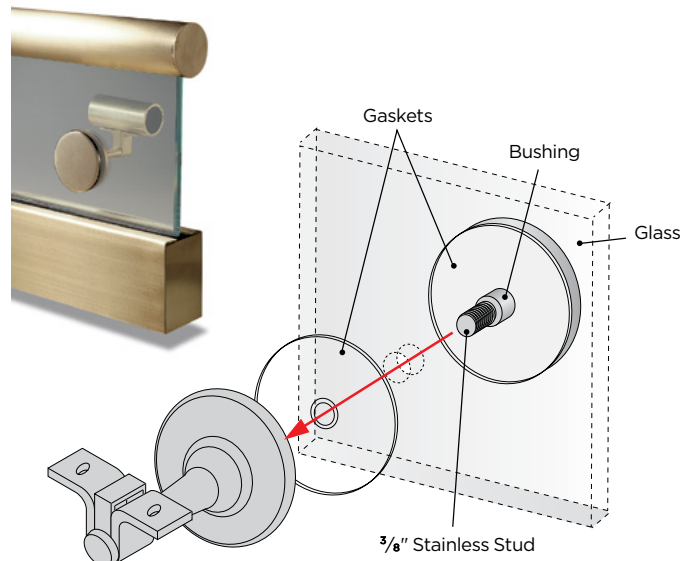

GLASS-MOUNTED HANDRAIL ADAPTER KIT

For 1/2" and 3/4" glass
Satin Finish

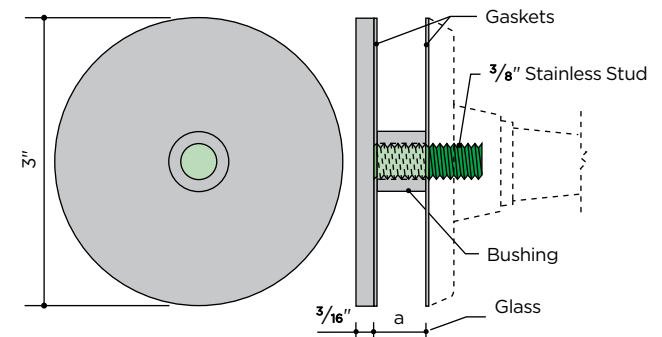

| | | Glass Size | a | Bushing Diameter |
|--------|---------------|------------|------|------------------|
| ● 824 | Bronze | 1/2" | 1/2" | 5/8" |
| ● 840 | Bronze | 3/4" | 3/4" | 7/8" |
| ● 224* | Stainless | 1/2" | 1/2" | 5/8" |
| ● 240* | Stainless | 3/4" | 3/4" | 7/8" |
| ● 1624 | Nickel-Silver | 1/2" | 1/2" | 5/8" |
| ● 1640 | Nickel-Silver | 3/4" | 3/4" | 7/8" |

* For use with aluminum and stainless brackets

● ALUMINUM ● BRONZE ● NICKEL-SILVER ● STAINLESS

CARLSTADT® SELF-ALIGNING WALL BRACKETS

Satin Finish

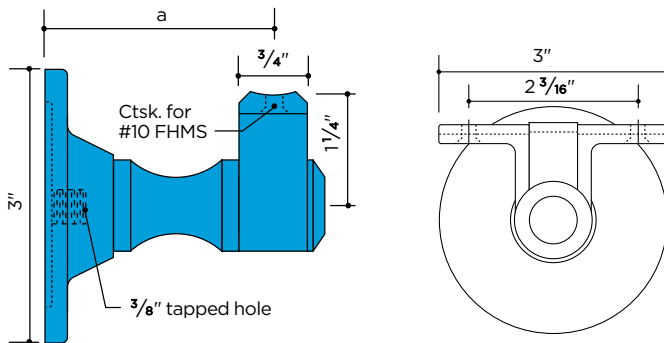

| | a |
|----------------|--------|
| ● 307 Aluminum | 2 1/2" |
| ● 308 Aluminum | 3" |



WALL BRACKETS

Cast, Satin Finish, for use with pipe railing

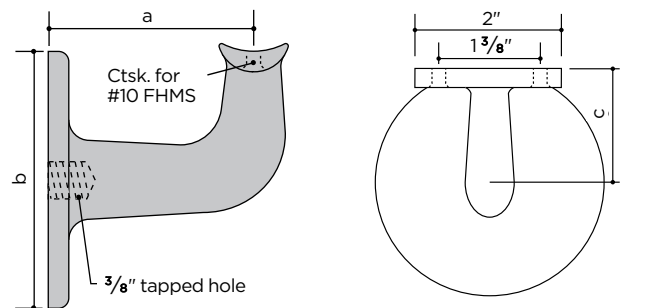

| | a | b | c |
|---------------------|--------|--------|---------|
| ● 376 Aluminum | 2 1/2" | 3 1/8" | 1 9/16" |
| ● 389 Aluminum | 3 1/8" | 3 3/4" | 1 7/8" |
| ● 375 Bronze | 2 1/2" | 3 1/8" | 1 9/16" |
| ● 319 Bronze | 3 1/8" | 3 3/4" | 1 7/8" |
| ● 176 Nickel-Silver | 2 1/2" | 3 1/8" | 1 9/16" |
| ● 275 Stainless | 2 1/2" | 3 1/8" | 1 9/16" |

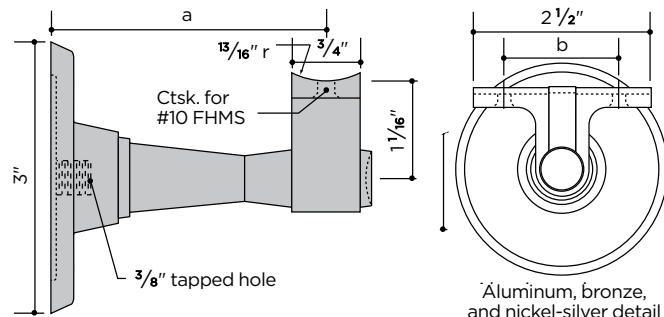

| | a | b |
|----------------------|--------|----------|
| ● 321 Aluminum | 2 1/4" | 1 5/8" |
| ● 403 Aluminum | 3" | 1 5/8" |
| ● 405 Aluminum | 3 1/2" | 1 5/8" |
| ● 842 Bronze | 2 1/4" | 1 5/8" |
| ● 801 Bronze | 2 1/2" | 1 5/8" |
| ● 803 Bronze | 3" | 1 5/8" |
| ● 1342 Nickel-Silver | 2 1/4" | 1 5/8" |
| ● 1303 Nickel-Silver | 3" | 1 5/8" |
| ● 242 Stainless | 2 1/4" | 1 13/16" |
| ● 221 Stainless | 2 1/2" | 1 13/16" |
| ● 223 Stainless | 3" | 1 13/16" |

Aluminum, bronze, and nickel-silver detail

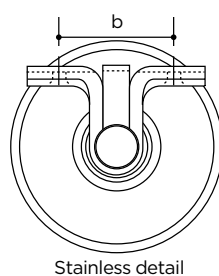

Stainless detail

WALL BRACKETS

Cast, Satin Finish

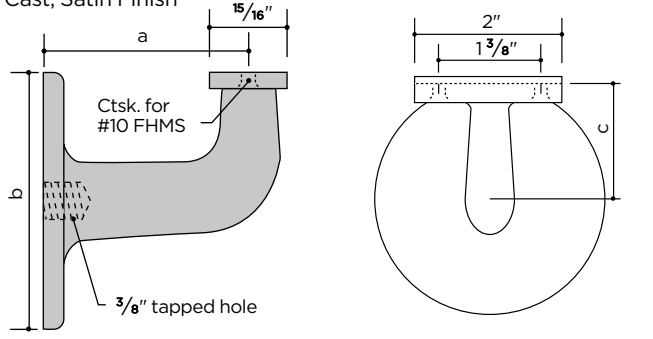

| | a | b | c |
|---------------------|--------|--------|---------|
| ● 371 Aluminum | 2 1/2" | 3 1/8" | 1 9/16" |
| ● 302 Aluminum | 3 1/8" | 3 3/4" | 1 7/8" |
| ● 370 Bronze | 2 1/2" | 3 1/8" | 1 9/16" |
| ● 304 Bronze | 3 1/8" | 3 3/4" | 1 7/8" |
| ● 170 Nickel-Silver | 2 1/2" | 3 1/8" | 1 9/16" |
| ● 270 Stainless | 2 1/2" | 3 1/8" | 1 9/16" |

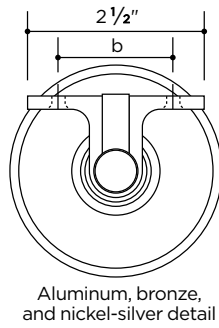
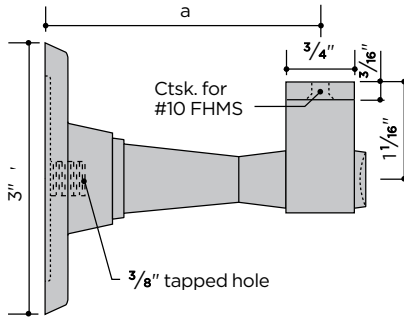

Aluminum, bronze, and nickel-silver detail

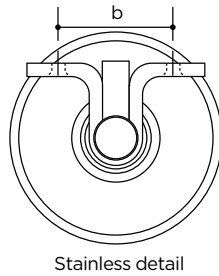

Stainless detail

| | a | b |
|----------------------|--------|----------|
| ● 443 Aluminum | 3" | 1 5/8" |
| ● 444 Aluminum | 3 1/2" | 1 5/8" |
| ● 844 Bronze | 2 1/2" | 1 5/8" |
| ● 843 Bronze | 3" | 1 5/8" |
| ● 1343 Nickel-Silver | 3" | 1 5/8" |
| ● 271 Stainless | 2 1/4" | 1 13/16" |
| ● 243 Stainless | 3" | 1 13/16" |

PIPE RAILINGS

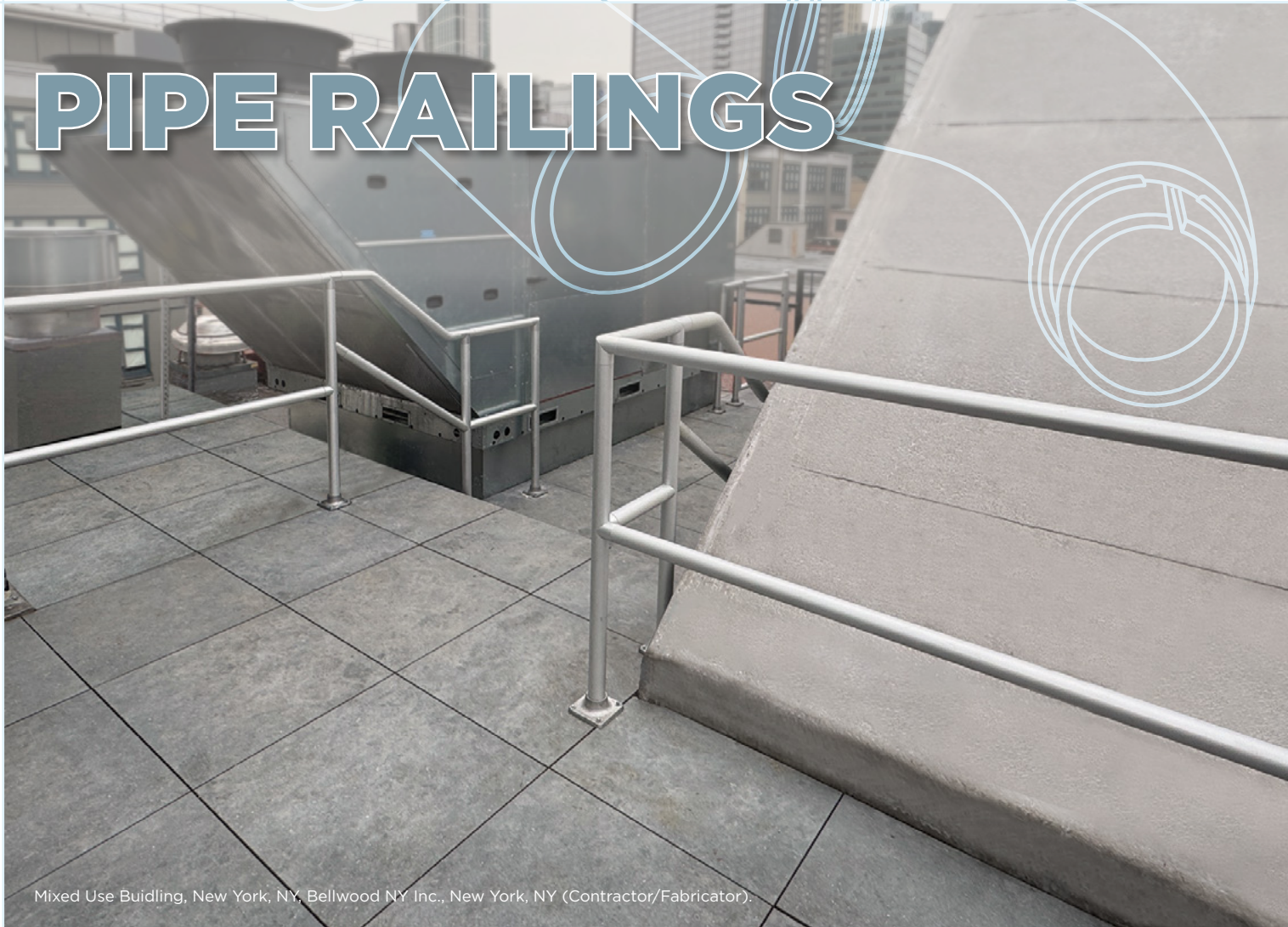

Mixed Use Building, New York, NY, Bellwood NY Inc., New York, NY (Contractor/Fabricator).

Connectorail® is an easy-to-assemble pipe railing system that is fabricated quickly without welding. Components slip together and are joined by concealed mechanical fasteners at intersections and by epoxy structural adhesive at splice joints.

The Connectorail® system has been engineered and tested to ensure structural strength and integrity when properly installed. Test results are available upon request. Connectorail® meets established safety standards when installed in accordance with our data and instructions.

- **Aluminum** Connectorail® components are stocked in 1¼" and 1½" pipe sizes—schedules 10 and 40—in alloy 6063 with either clear anodized—AA-M10-C22-A31 (204R1)—or smooth mill finish. Connectorail® pipe is specially extruded to close dimensional tolerances with a clean smooth surface finish. Aluminum pipe is stocked in mill-wrapped, paper-interleaved bundles of approximately 100 pounds. Aluminum pipe is suitable for powder coating and anodizing, including most of the hard coat anodic processes. Black anodizing may result in inconsistent matches. Consult your anodizer before specifying.
- **Bronze** Connectorail® is supplied in 1¼" and 1½" pipe sizes in drawn pipe alloy C23000 (Red Brass) with a smooth mill finish. Bronze fittings are satin finished—(180 grit)—and lacquered.

- **Nickel-Silver** Connectorail® is available in extruded 1½" schedule 10 pipe in alloy C79800 with a smooth mill finish. Radius elbows are supplied similarly. All other components are satin finished—(180 grit)—and lacquered.

- **Stainless Steel** (type 304) components are furnished with a No. 4 satin finish in 1½" schedule 5 pipe size in an Ornamental Grade with a guaranteed expected yield of 55,000 [psi]. The pipe is sleeved for surface protection.

Stainless Connectorail® can also be fabricated by welding. The use of Connectorail® stainless steel fittings eliminates notching and grinding and permits rapid welding with a minimum addition of weld metal.

Fittings for welded assembly are available in cast aluminum, bronze, iron, malleable iron, formed steel, and stainless steel. Flanges and elbows are available for aluminum, bronze, nickel-silver, and stainless OD tubing. All items are carried in stock in substantial quantities and are available for immediate shipment. The *Americans with Disabilities Act* adopted by Congress in 1992 specified circular handrails to be 1¼" minimum and 1½" maximum. However, the *Guidance on the 2010 ADA Standards for Accessible Design - September 2010*, published by the US Department of Justice, has now properly clarified the intent of the dimensional requirements to be an outside diameter of 1¼" to 2".

| | | | | | | |
|--------------------|-------------------|---------------------------|-------------------|---------------------|-----------------|----------------|
| FITTING KEY: | | D Heavy-Duty Floor Flange | G Angle Tee | L Gate Latch & Stop | Q Toe Board | U Return Elbow |
| A 90° Radius Elbow | E Rail Elbow | H Post Elbow | J Gate Hinge | M 90° Corner Tee | R Ramp Rail Tee | W Wall Bracket |
| B 90° Tee | F Ramp Rail Elbow | K Post Bracket | N 90° Miter Elbow | P 90° 3-Way Elbow | S Cover Flange | X Socket |
| C Connector Sleeve | | | | | T Fascia Flange | Y Panel Clip |

Verify all dimensions before cutting. Aluminum components and pipe are carried in stock with a mill finish or a clear anodized finish—AA-M10-C22-A31 (204R1). When specifying anodized fittings, add the suffix -A to catalog number listed (e.g. **7140-A**).

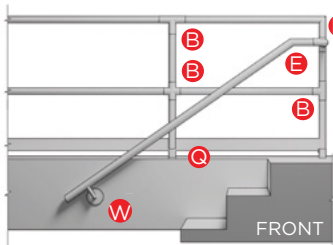
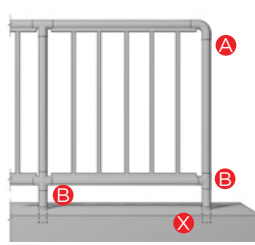
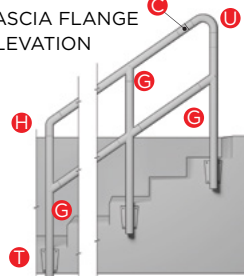
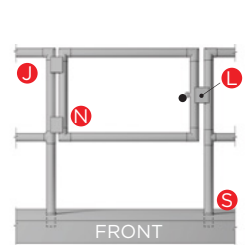
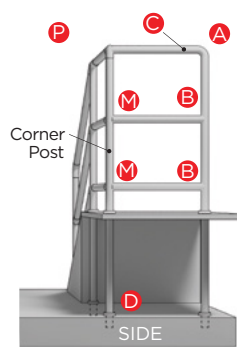
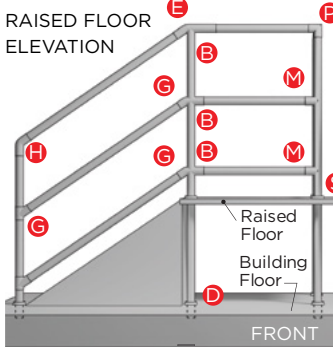
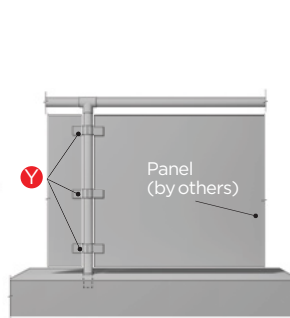
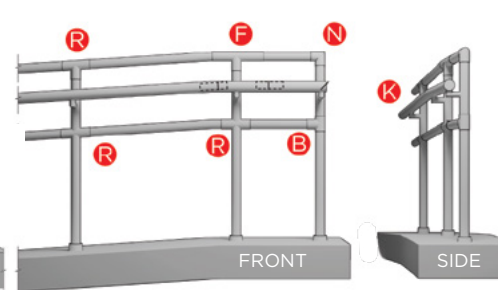
STAIR ELEVATION

BALUSTER RAIL

FASCIA FLANGE ELEVATION

GATE ASSEMBLY

RAISED FLOOR ELEVATION

PANEL RAIL

RAMP RAIL ELEVATION (Offset Handrail Optional)

FULL RANGE OF FITTINGS

A complete selection of fittings is offered for the Connectorail® system. A suitable fitting is available for practically any stair or ramp railing condition. Adjustable handrail brackets and ramp rail tees are recommended for unusual ramp or stair angles.



MECHANICAL CONNECTIONS

Non-welded connections eliminate welding discoloration and expensive grinding. Structural adhesive, stainless steel machine screws with lock washers, and threaded tubular rivets provide positive connections at joints. Mechanical connections avoid the reduced allowable design stress effect of welding heat on the structural properties of aluminum handrail pipe.



OPTIONS FOR MOUNTING

Connectorail® posts may be embedded in floor slab with a cover flange, surface mounted with a heavy-duty floor flange, or side mounted on fascia or stringer by means of a fascia flange. A reinforcing insert is used at the base of the post for added strength and stiffness. A socket for removable railings—with cover—is also available.



CONTINUOUS POSTS AND RAILS

Posts and top rails run in continuous lengths, thus providing a system that is inherently stronger than one with cast tee and cross connections. Connectorail® has a continuous, smooth top surface as required by established safety standards and code requirements. The structural integrity of the railing depends on the proper selection of components, location of posts, and proper assembly and installation.

● ALUMINUM ● BRONZE ● NICKEL-SILVER ● STAINLESS

CONNECTORAIL® PIPE

20' Lengths

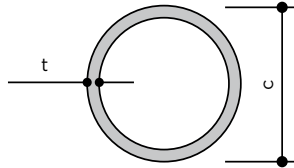

- Aluminum: Alloy 6063-T52 and Alloy 6063-T832 clear anodized or mill finish
- Bronze: C23000, smooth mill finish
- Nickel-Silver: C79800, smooth mill finish
- Stainless: Type 304, ornamental grade, No. 4 finish

| | Pipe | Sched. | t | c | lb/ft |
|-----------------|--------|--------|-------|--------|-------|
| ● Aluminum | 1 1/4" | 10 | .109" | 1.660" | .625 |
| ● Aluminum | 1 1/4" | 40 | .140" | 1.660" | .785 |
| ● Aluminum | 1 1/2" | 10 | .109" | 1.900" | .721 |
| ● Aluminum | 1 1/2" | 40 | .145" | 1.900" | .940 |
| ● Bronze | 1 1/4" | 40 | .146" | 1.660" | 2.630 |
| ● Bronze | 1 1/2" | 40 | .150" | 1.900" | 3.130 |
| ● Nickel-Silver | 1 1/2" | 10 | .109" | 1.900" | 2.250 |
| ● Stainless | 1 1/2" | 5 | .062" | 1.900" | 1.274 |

HIGH STRENGTH CONNECTORAIL® POSTS

Aluminum only

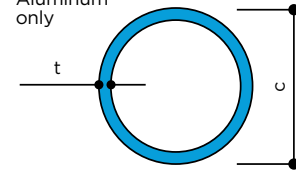

Alloy 6063-T832
Drawn pipe precut to post lengths.
Clear anodized or mill finish

| | Pipe | Sched. | Length | c | t | |
|--------|----------|--------|--------|-----|--------|-------|
| ● 7103 | Aluminum | 1 1/4" | 10 | 38" | 1.660" | .109" |
| ● 7104 | Aluminum | 1 1/4" | 10 | 50" | 1.660" | .109" |
| ● 7403 | Aluminum | 1 1/4" | 40 | 38" | 1.660" | .140" |
| ● 7404 | Aluminum | 1 1/4" | 40 | 50" | 1.660" | .140" |
| ● 7203 | Aluminum | 1 1/2" | 10 | 38" | 1.900" | .109" |
| ● 7204 | Aluminum | 1 1/2" | 10 | 50" | 1.900" | .109" |
| ● 7503 | Aluminum | 1 1/2" | 40 | 38" | 1.900" | .145" |
| ● 7504 | Aluminum | 1 1/2" | 40 | 50" | 1.900" | .145" |

90° TEE

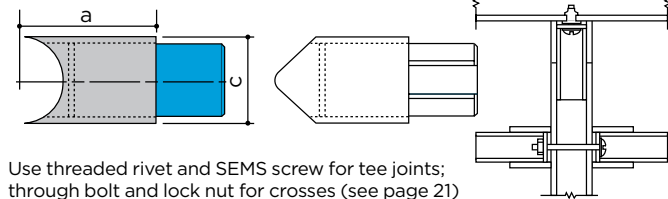

Use threaded rivet and SEMS screw for tee joints;
through bolt and lock nut for crosses (see page 21)

| | Pipe | Sched. | c | a | |
|--------|---------------|--------|----|--------|----|
| ● 7140 | Aluminum | 1 1/4" | 10 | 1.660" | 2" |
| ● 7440 | Aluminum | 1 1/4" | 40 | 1.660" | 2" |
| ● 7240 | Aluminum | 1 1/2" | 10 | 1.900" | 2" |
| ● 7540 | Aluminum | 1 1/2" | 40 | 1.900" | 2" |
| ● 8640 | Bronze | 1 1/4" | 40 | 1.660" | 3" |
| ● 8840 | Bronze | 1 1/2" | 40 | 1.900" | 3" |
| ● 1340 | Nickel-Silver | 1 1/2" | 10 | 1.900" | 2" |
| ● 9340 | Stainless | 1 1/2" | 5 | 1.900" | 3" |

90° CORNER TEE

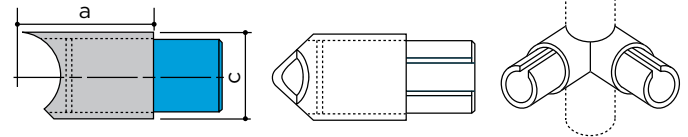

| | Pipe | Sched. | c | a | |
|--------|-----------|--------|----|--------|----|
| ● 7141 | Aluminum | 1 1/4" | 10 | 1.660" | 2" |
| ● 7441 | Aluminum | 1 1/4" | 40 | 1.660" | 2" |
| ● 7241 | Aluminum | 1 1/2" | 10 | 1.900" | 2" |
| ● 7541 | Aluminum | 1 1/2" | 40 | 1.900" | 2" |
| ● 9341 | Stainless | 1 1/2" | 5 | 1.900" | 3" |

90° 6" TEE

Aluminum only

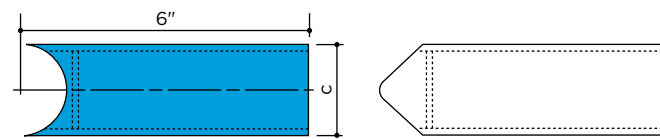

| | Pipe | Sched. | c | |
|--------|----------|--------|----|--------|
| ● 7150 | Aluminum | 1 1/4" | 10 | 1.660" |
| ● 7450 | Aluminum | 1 1/4" | 40 | 1.660" |
| ● 7250 | Aluminum | 1 1/2" | 10 | 1.900" |
| ● 7550 | Aluminum | 1 1/2" | 40 | 1.900" |

90° RADIUS ELBOW

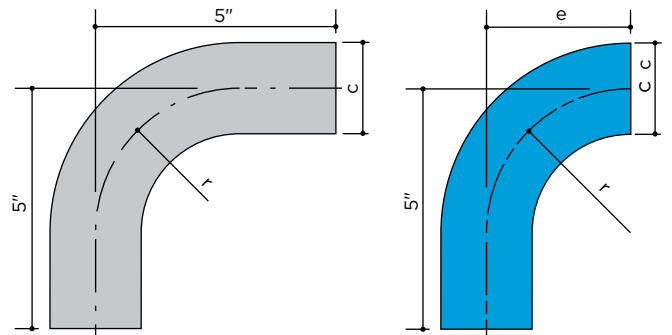

| | Pipe | Sched. | c | r | e | |
|---------|---------------|--------|----|--------|--------|--------|
| ● 7110 | Aluminum | 1 1/4" | 10 | 1.660" | 2 1/2" | |
| ● 7120* | Aluminum | 1 1/4" | 10 | 1.660" | 2 1/2" | 2 1/2" |
| ● 7410 | Aluminum | 1 1/4" | 40 | 1.660" | 2 1/2" | |
| ● 7420* | Aluminum | 1 1/4" | 40 | 1.660" | 2 1/2" | 2 1/2" |
| ● 7210 | Aluminum | 1 1/2" | 10 | 1.900" | 3" | |
| ● 7220* | Aluminum | 1 1/2" | 10 | 1.900" | 3" | 3" |
| ● 7510 | Aluminum | 1 1/2" | 40 | 1.900" | 3" | |
| ● 7520* | Aluminum | 1 1/2" | 40 | 1.900" | 3" | 3" |
| ● 8610 | Bronze | 1 1/4" | 40 | 1.660" | 2 1/2" | |
| ● 8810 | Bronze | 1 1/2" | 40 | 1.900" | 3" | |
| ● 1330C | Nickel-Silver | 1 1/2" | 10 | 1.900" | 3" | |
| ● 9310 | Stainless | 1 1/2" | 5 | 1.900" | 3" | |

*For wall return

CONNECTOR SLEEVES

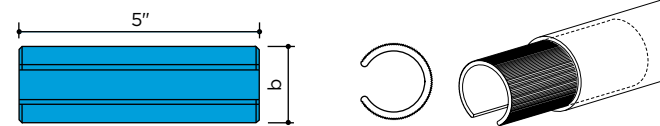

Serrated for drive fit into Connectorail® pipe

| | Pipe | Sched. | b | |
|--------|----------|--------|----|--------|
| ● 7163 | Aluminum | 1 1/4" | 10 | 1.442" |
| ● 7463 | Aluminum | 1 1/4" | 40 | 1.380" |
| ● 7263 | Aluminum | 1 1/2" | 10 | 1.682" |
| ● 7563 | Aluminum | 1 1/2" | 40 | 1.610" |
| ● 9363 | Aluminum | 1 1/2" | 5 | 1.770" |

● ALUMINUM ● BRONZE ● NICKEL-SILVER ● STAINLESS

90° THREE-WAY ELBOW

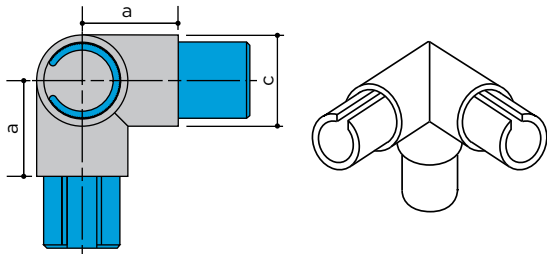

| | | Pipe | Sched. | c | a |
|--------|-----------|--------|--------|--------|----|
| ● 7130 | Aluminum | 1 1/4" | 10 | 1.660" | 2" |
| ● 7430 | Aluminum | 1 1/4" | 40 | 1.660" | 2" |
| ● 7230 | Aluminum | 1 1/2" | 10 | 1.900" | 2" |
| ● 7530 | Aluminum | 1 1/2" | 40 | 1.900" | 2" |
| ● 9330 | Stainless | 1 1/2" | 5 | 1.900" | 3" |

90° MITER ELBOW

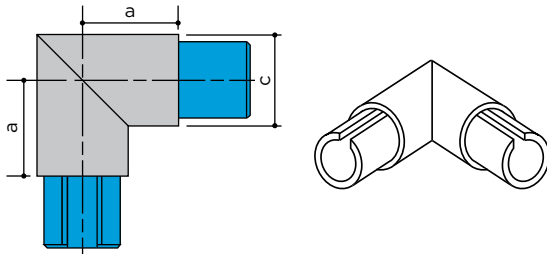

| | | Pipe | Sched. | c | a |
|--------|-----------|--------|--------|--------|----|
| ● 7111 | Aluminum | 1 1/4" | 10 | 1.660" | 2" |
| ● 7411 | Aluminum | 1 1/4" | 40 | 1.660" | 2" |
| ● 7211 | Aluminum | 1 1/2" | 10 | 1.900" | 2" |
| ● 7511 | Aluminum | 1 1/2" | 40 | 1.900" | 2" |
| ● 9311 | Stainless | 1 1/2" | 5 | 1.900" | 3" |

WALL RETURN

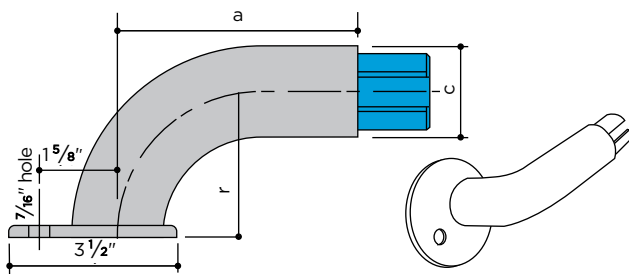

| | | Pipe | Sched. | c | r | a |
|----------|---------------|--------|--------|--------|--------|----|
| ● 7173 | Aluminum | 1 1/4" | 10 | 1.660" | 2 1/2" | 5" |
| ● 7473 | Aluminum | 1 1/4" | 40 | 1.660" | 2 1/2" | 5" |
| ● 7473-3 | Aluminum | 1 1/4" | 40 | 1.660" | 3" | 5" |
| ● 7273 | Aluminum | 1 1/2" | 10 | 1.900" | 3" | 5" |
| ● 7573 | Aluminum | 1 1/2" | 40 | 1.900" | 3" | 5" |
| ● 8673 | Bronze | 1 1/4" | 40 | 1.660" | 2 1/2" | 5" |
| ● 8873 | Bronze | 1 1/2" | 40 | 1.900" | 3" | 5" |
| ● 1373 | Nickel-Silver | 1 1/2" | 10 | 1.900" | 3" | 6" |
| ● 9373 | Stainless | 1 1/2" | 5 | 1.900" | 3" | 5" |
| ● 9372 | Stainless | 1 1/2" | 5 | 1.900" | 2 1/2" | 5" |

RAMP RAIL TEE

Aluminum only

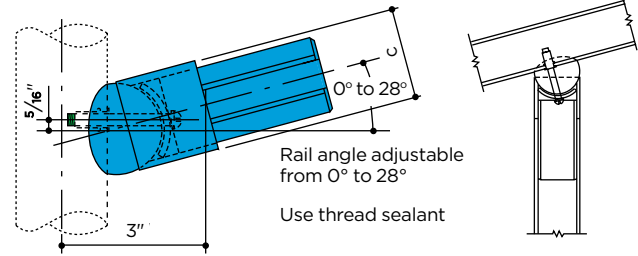

| | | Pipe | Sched. | c |
|--------|----------|--------|--------|--------|
| ● 7443 | Aluminum | 1 1/4" | 40 | 1.660" |
| ● 7243 | Aluminum | 1 1/2" | 10 | 1.900" |
| ● 7543 | Aluminum | 1 1/2" | 40 | 1.900" |

POST CAPS

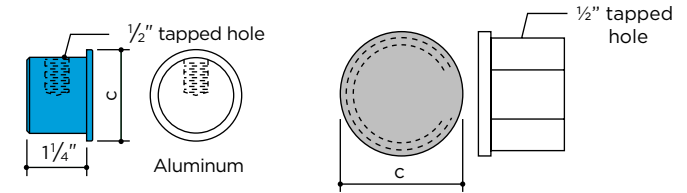

| | | Pipe | Sched. | c |
|---------|---------------|--------|--------|--------|
| ● 7180 | Aluminum | 1 1/4" | 10 | 1.660" |
| ● 7480 | Aluminum | 1 1/4" | 40 | 1.660" |
| ● 7280 | Aluminum | 1 1/2" | 10 | 1.900" |
| ● 7580 | Aluminum | 1 1/2" | 40 | 1.900" |
| ● 1330N | Nickel-Silver | 1 1/2" | 10 | 1.900" |
| ● 9380 | Stainless | 1 1/2" | 5 | 1.900" |

Flat post caps are drilled and tapped to provide secure mounting for handrail brackets

END CAPS

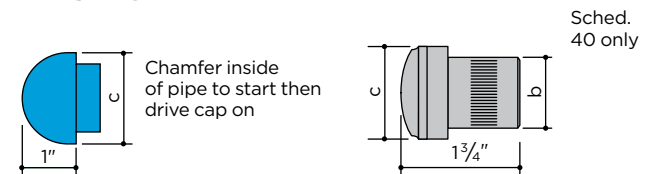

| | | Pipe | Sched. | c | Pipe | b | c | |
|--------|-----|--------|--------|--------|--------|-----|--------|-------------|
| ● 7181 | Al. | 1 1/4" | 10 | 1.660" | ● 707* | Al. | 1 1/4" | 1.38 1.660" |
| ● 7481 | Al. | 1 1/4" | 40 | 1.660" | ● 708* | Al. | 1 1/2" | 1.61 1.900" |
| ● 7281 | Al. | 1 1/2" | 10 | 1.900" | ● 807* | Br. | 1 1/4" | 1.37 1.660" |
| ● 7581 | Al. | 1 1/2" | 40 | 1.900" | ● 808* | Br. | 1 1/2" | 1.60 1.900" |

* Satin Finish



9330



807

ANGLE FITTING SELECTOR CHART

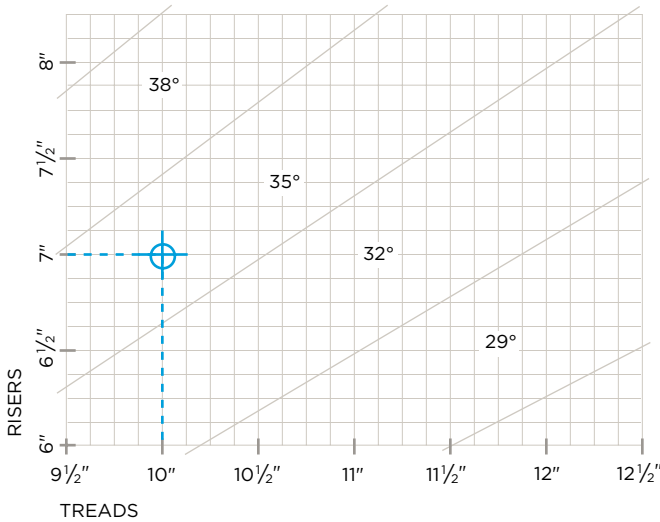

Angle fittings are carried in stock for 29°, 32°, 35°, and 38° angles of inclination. To select the correct angle fitting for a stairway, plot the intersection of riser and tread dimensions on the chart above. The zone into which the intersection falls will indicate the correct angle value for fittings.

Example: A 7" riser and a 10" tread require 35° angle fittings.

POST ELBOW

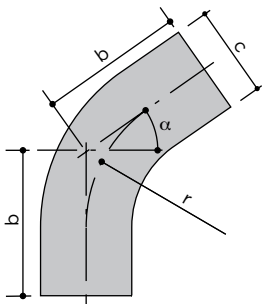

b = 4" for 4° post elbows, while
b = 3" for all other post elbows.

| 45°α | Pipe | Sched. | c | r |
|------|-------|--------|----|---------------|
| 7408 | Alum. | 1 1/4" | 40 | 1.660" 2 1/2" |
| 7208 | Alum. | 1 1/2" | 10 | 1.900" 3" |
| 7508 | Alum. | 1 1/2" | 40 | 1.900" 3" |

| 4°α | 29°α | 32°α | 35°α | 38°α | Pipe | Sched. | c | r |
|------|------|------|------|------|---------|--------|----|---------------|
| 7119 | 7122 | 7125 | 7128 | | Alum. | 1 1/4" | 10 | 1.660" 2 1/2" |
| 7416 | 7419 | 7422 | 7425 | 7428 | Alum. | 1 1/4" | 40 | 1.660" 2 1/2" |
| 7216 | 7219 | 7222 | 7225 | 7228 | Alum. | 1 1/2" | 10 | 1.900" 3" |
| 7516 | 7519 | 7522 | 7525 | 7528 | Alum. | 1 1/2" | 40 | 1.900" 3" |
| 9316 | 9319 | 9322 | 9325 | 9328 | St. St. | 1 1/2" | 5 | 1.900" 3" |

RAIL ELBOW

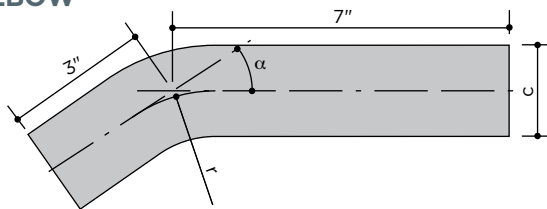

| 29°α | 32°α | 35°α | 38°α | Pipe | Sched. | c | r |
|------|------|------|------|---------|--------|----|---------------|
| 7109 | 7112 | 7115 | 7118 | Alum. | 1 1/4" | 10 | 1.660" 2 1/2" |
| 7409 | 7412 | 7415 | 7418 | Alum. | 1 1/4" | 40 | 1.660" 2 1/2" |
| 7209 | 7212 | 7215 | 7218 | Alum. | 1 1/2" | 10 | 1.900" 3" |
| 7509 | 7512 | 7515 | 7518 | Alum. | 1 1/2" | 40 | 1.900" 3" |
| 9309 | 9312 | 9315 | 9318 | St. St. | 1 1/2" | 5 | 1.900" 3" |

ALUMINUM (blue dot) STAINLESS (green dot)

RETURN ELBOW

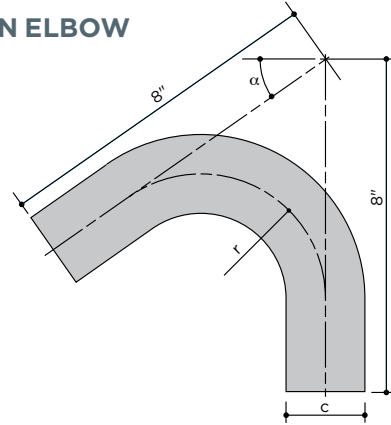

| 29°α | 32°α | 35°α | 38°α | Pipe | Sched. | c | r |
|------|------|------|------|---------|--------|----|---------------|
| 7179 | 7182 | 7185 | 7188 | Alum. | 1 1/4" | 10 | 1.660" 2 1/2" |
| 7479 | 7482 | 7485 | 7488 | Alum. | 1 1/4" | 40 | 1.660" 2 1/2" |
| 7279 | 7282 | 7285 | 7288 | Alum. | 1 1/2" | 10 | 1.900" 3" |
| 7579 | 7582 | 7585 | 7588 | Alum. | 1 1/2" | 40 | 1.900" 3" |
| 9379 | 9382 | 9385 | 9388 | St. St. | 1 1/2" | 5 | 1.900" 3" |

ANGLE TEE

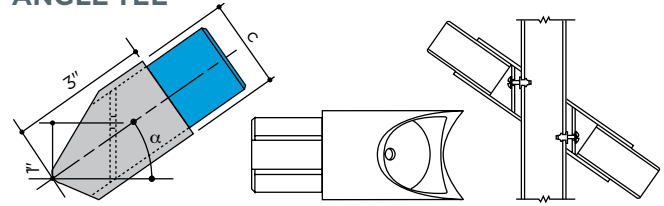

| 45°α | Pipe | Sched. | c |
|------|-------|--------|-----------|
| 7451 | Alum. | 1 1/4" | 40 1.660" |
| 7551 | Alum. | 1 1/2" | 40 1.900" |

| 4°α | 29°α | 32°α | 35°α | 38°α | Pipe | Sched. | c |
|-------|------|------|------|------|---------|--------|-----------|
| 7139 | 7142 | 7145 | 7148 | | Alum. | 1 1/4" | 10 1.660" |
| 7444* | 7439 | 7442 | 7445 | 7448 | Alum. | 1 1/4" | 40 1.660" |
| 7244* | 7239 | 7242 | 7245 | 7248 | Alum. | 1 1/2" | 10 1.900" |
| 7544* | 7539 | 7542 | 7545 | 7548 | Alum. | 1 1/2" | 40 1.900" |
| 9344* | 9339 | 9342 | 9345 | 9348 | St. St. | 1 1/2" | 5 1.900" |

*On 4° angle tees, the screw hole is located in the center of the washer.

RAMP RAIL ELBOW

| angle | slope | gradient |
|-------|-------|----------|
| 4° | 14:1 | 7.0% |
| 7° | 8:1 | 12.3% |
| 10° | 6:1 | 17.6% |

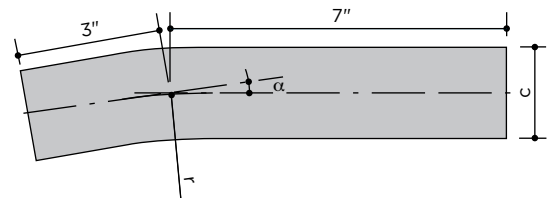

| 4°α | 7°α | 10°α | Pipe | Sched. | c | r |
|------|------|------|---------|--------|----|---------------|
| 7405 | 7406 | 7407 | Alum. | 1 1/4" | 40 | 1.660" 2 1/2" |
| 7205 | 7206 | 7207 | Alum. | 1 1/2" | 10 | 1.900" 3" |
| 7505 | 7506 | 7507 | Alum. | 1 1/2" | 40 | 1.900" 3" |
| 9305 | | | St. St. | 1 1/2" | 5 | 1.900" 3" |

● ALUMINUM ● BRONZE ● NICKEL-SILVER ● STAINLESS

COVER FLANGE

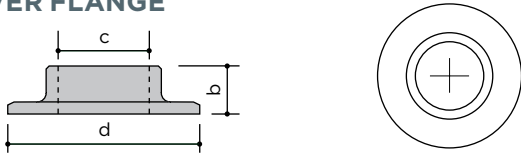

| | | Pipe | Sched. | b | c | d |
|-------|---------------|--------|--------|------|--------|----------|
| ● 710 | Aluminum | 1 1/4" | all | 1" | 1.688" | 3 13/16" |
| ● 711 | Aluminum | 1 1/2" | all | 1" | 1.938" | 4" |
| ● 810 | Bronze | 1 1/4" | all | 1" | 1.688" | 3 13/16" |
| ● 811 | Bronze | 1 1/2" | all | 1" | 1.938" | 4" |
| ● 411 | Nickel-Silver | 1 1/2" | all | 1" | 1.938" | 4" |
| ● 211 | Stainless | 1 1/2" | all | 7/8" | 1.938" | 4 1/2" |

HEAVY-DUTY FLOOR FLANGE

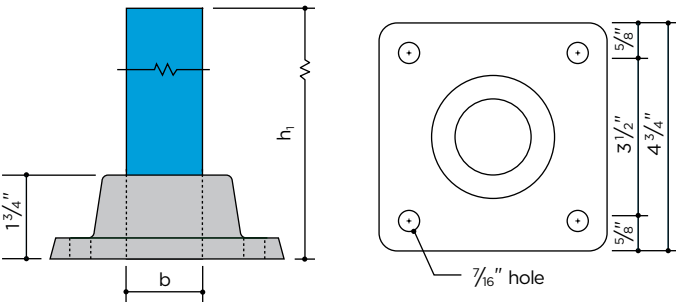

| | | Pipe | Sched. | h ₁ | b |
|---------|----------|--------|--------|----------------|--------|
| ● 7471 | Aluminum | 1 1/4" | 40 | 12" | 1.360" |
| ● 7271 | Aluminum | 1 1/2" | 10 | 12" | 1.667" |
| ● 7571 | Aluminum | 1 1/2" | 40 | 12" | 1.585" |
| ● 9371* | Aluminum | 1 1/2" | 5 | 18" | 1.750" |

* For use with Stainless Steel System. See page 21 for anchor bolt.

FLOOR FLANGE †

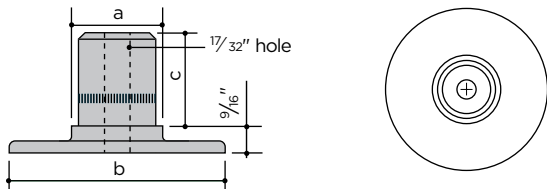

| | | Pipe | Sched. | a | b | c |
|--------|---------------|--------|--------|--------|--------|----------|
| ● 7170 | Aluminum | 1 1/4" | 10 | 1.660" | 4" | 1 13/16" |
| ● 727 | Aluminum | 1 1/4" | 40 | 1.660" | 4" | 1 13/16" |
| ● 7270 | Aluminum | 1 1/2" | 10 | 1.900" | 4 1/2" | 2 1/16" |
| ● 728 | Aluminum | 1 1/2" | 40 | 1.900" | 4 1/2" | 2 1/16" |
| ● 827 | Bronze | 1 1/4" | 40 | 1.660" | 4" | 1 13/16" |
| ● 828 | Bronze | 1 1/2" | 40 | 1.900" | 4 1/2" | 2 1/16" |
| ● 1328 | Nickel-Silver | 1 1/2" | 10 | 1.900" | 4 1/2" | 2 1/16" |

OVAL FLOOR FLANGE †

Aluminum only

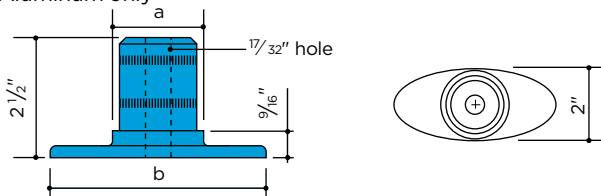

| | | Pipe | Sched. | a | b |
|-------|----------|--------|--------|--------|--------|
| ● 749 | Aluminum | 1 1/4" | 40 | 1.660" | 4" |
| ● 750 | Aluminum | 1 1/2" | 40 | 1.900" | 4 1/2" |

† When using these floor flanges for surface mounting of posts, care must be taken to provide adequate lateral bracing or end support. For freestanding railings, use the heavy-duty floor flange.

FASCIA FLANGE

Fascia flanges are supplied complete with two 3/8" stainless steel bolts for assembly to pipe posts. Stainless steel fascia flanges use two round stand-offs and a stainless steel tubular reinforcing bar. The aluminum and bronze fascia flanges use a single adapter bar and a solid aluminum reinforcing bar.

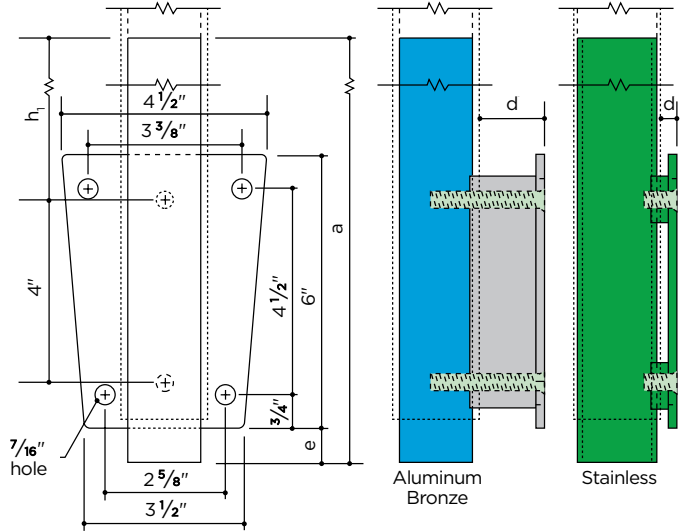
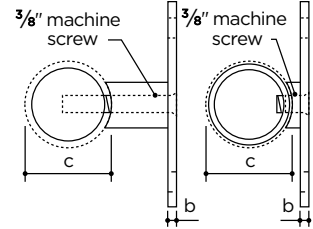

| | | Pipe | Sched. | a | b | c | d | e | h ₁ |
|--------|---------|--------|--------|-----|-------|--------|--------|------|----------------|
| ● 7190 | Alum. | 1 1/4" | 10 | 15" | 5/16" | 1.660" | 7/16" | 3/4" | 9 1/4" |
| ● 7191 | Alum. | 1 1/4" | 10 | 15" | 5/16" | 1.660" | 19/16" | 3/4" | 9 1/4" |
| ● 755 | Alum. | 1 1/4" | 40 | 15" | 5/16" | 1.660" | 7/16" | 3/4" | 9 1/4" |
| ● 756 | Alum. | 1 1/4" | 40 | 15" | 5/16" | 1.660" | 19/16" | 3/4" | 9 1/4" |
| ● 7290 | Alum. | 1 1/2" | 10 | 15" | 5/16" | 1.900" | 7/16" | 1" | 9 1/4" |
| ● 7291 | Alum. | 1 1/2" | 10 | 15" | 5/16" | 1.900" | 19/16" | 3/4" | 9 1/4" |
| ● 7293 | Alum. | 1 1/2" | 10 | 24" | 5/16" | 1.900" | 7/16" | 3/4" | 18 1/4" |
| ● 7294 | Alum. | 1 1/2" | 10 | 24" | 5/16" | 1.900" | 19/16" | 1" | 18 1/4" |
| ● 757 | Alum. | 1 1/2" | 40 | 15" | 5/16" | 1.900" | 7/16" | 1/2" | 9 1/4" |
| ● 758 | Alum. | 1 1/2" | 40 | 15" | 5/16" | 1.900" | 19/16" | 1/2" | 9 1/4" |
| ● 7593 | Alum. | 1 1/2" | 40 | 24" | 5/16" | 1.900" | 7/16" | 1" | 18 1/4" |
| ● 7594 | Alum. | 1 1/2" | 40 | 24" | 5/16" | 1.900" | 19/16" | 1/2" | 18 1/4" |
| ● 8893 | Bronze | 1 1/2" | 40 | 24" | 5/16" | 1.900" | 7/16" | 3/4" | 18 1/4" |
| ● 8894 | Bronze | 1 1/2" | 40 | 24" | 5/16" | 1.900" | 19/16" | 3/4" | 18 1/4" |
| ● 9390 | St. St. | 1 1/2" | 5 | 26" | 1/4" | 1.900" | 3/8" | 1/2" | 20 1/2" |
| ● 9391 | St. St. | 1 1/2" | 5 | 26" | 1/4" | 1.900" | 1 1/2" | 1/2" | 20 1/2" |

See page 21 for anchor bolt.

ROOF RAILING FLANGE

Aluminum only

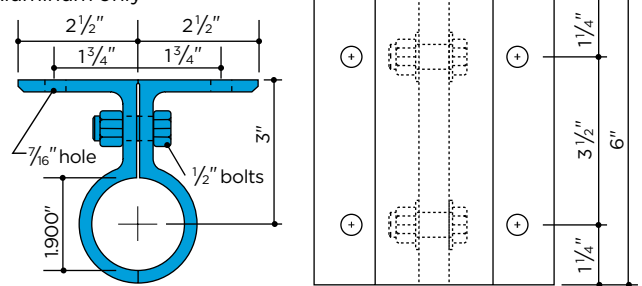

| | | Pipe | Sched. |
|-------|----------|--------|--------|
| ● 748 | Aluminum | 1 1/2" | all |

See page 21 for anchor bolt.

PIPE
RAILINGS

● ALUMINUM ● BRONZE ● NICKEL-SILVER ● STAINLESS

TOE BOARD

20' lengths

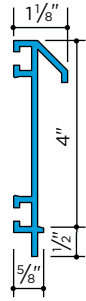

| | lb/ft |
|--------------|-------|
| ● 6446 Alum. | 1.13 |

TOE BOARD CLAMPS

For 1 1/2" pipe

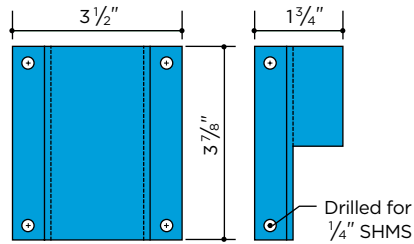
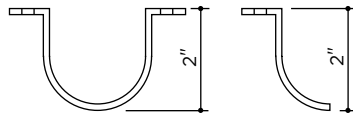

| | |
|----------------|----------------|
| ● 746 Aluminum | ● 747 Aluminum |
|----------------|----------------|



Mixed Use Building, New York, NY, Bellwood NY Inc., New York, NY (Contractor/Fabricator).

Toe board clamps are supplied with stainless steel screws and nuts.

Assembly Details

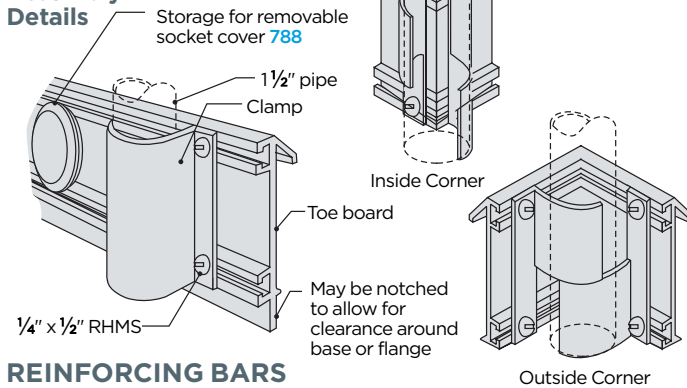

REINFORCING BARS

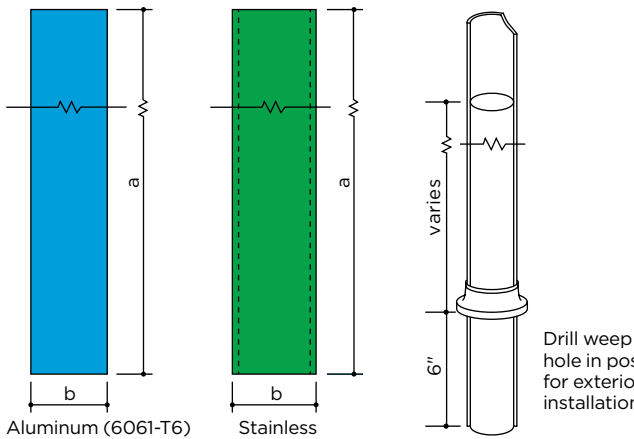

| | Pipe | Sched. | b | a |
|-------------------|--------|--------|---------------------|-----|
| ● 7192 Aluminum | 1 1/4" | 10 | 1.427" | 15" |
| ● 7492** Aluminum | 1 1/4" | 40 | 1.360" | 15" |
| ● 7292* Aluminum | 1 1/2" | 10 | 1.667" | 15" |
| ● 7295* Aluminum | 1 1/2" | 10 | 1.667" | 24" |
| ● 7592** Aluminum | 1 1/2" | 40 | 1.585" | 15" |
| ● 7595** Aluminum | 1 1/2" | 40 | 1.585" | 24" |
| ● 9392 Stainless | 1 1/2" | 5 | 1.750" x .120" wall | 26" |

* For use with aluminum and nickel-silver pipe.
 ** For use with aluminum and bronze pipe.

Floor mounting is best accomplished by mounting in concrete. Post inserts are recommended for reinforcing floor-mounted posts.



REMOVABLE RAIL SOCKET, COVER AND COLLAR

SOCKET

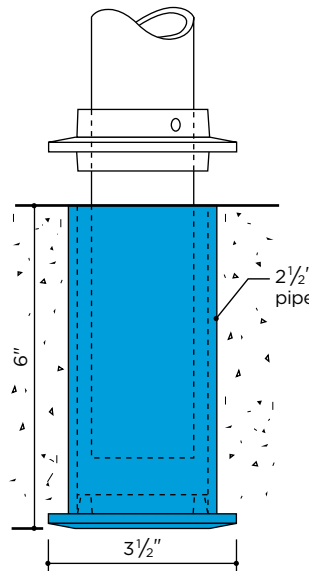

| | |
|-------|----------|
| ● 786 | Aluminum |
|-------|----------|

PIPE COLLAR
For 1 1/2" pipe only

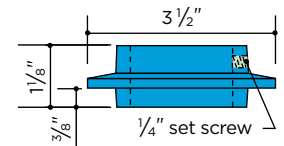

| | |
|-------|----------|
| ● 787 | Aluminum |
|-------|----------|

SOCKET COVER

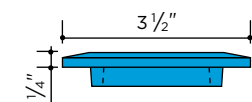

| | |
|-------|----------|
| ● 788 | Aluminum |
|-------|----------|

Socket cover fits tightly but can be pried loose with a screwdriver. When railing is in place, cover may be stored in the side of the toe board.

● ALUMINUM ● STAINLESS ● STEEL

GATE HINGE

For 1½" aluminum pipe only

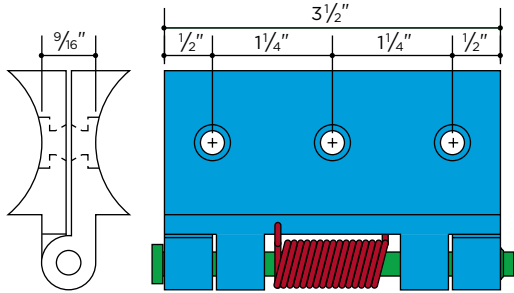

● 782/3 Aluminum

Supplied in sets of two—one plain and one with a self-closing spring

GATE LATCH AND STOP

For 1½" aluminum pipe only

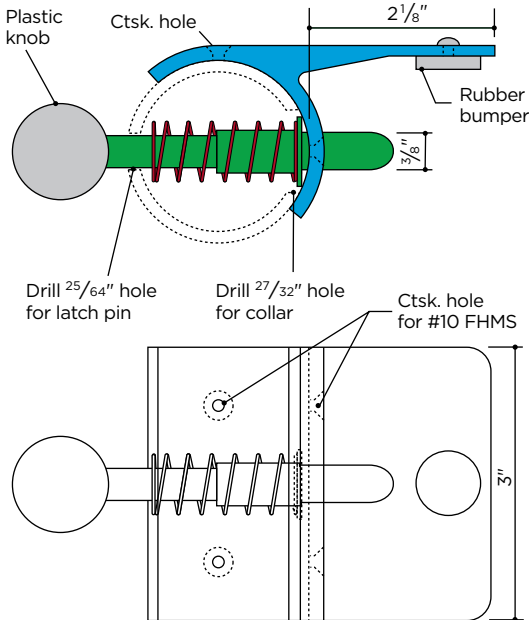

● 784 Aluminum

SCOTCH-WELD® EPOXY ADHESIVE

Catalog No. 3M EC-2216 B/A ClearAmber
Recommended for splice joints using connector sleeves.
The areas to be joined should be cleaned thoroughly.
The adhesive is mixed according to manufacturer's directions.



Tubes — 4 oz. total

MANUAL RIVET HEADER

The Manual Rivet Header is a low-cost hand tool for setting the internally threaded tubular rivets.



Thread Setter™

TUBULAR RIVETS

● Aluminum

Set tubular rivet in hole, using setting tool. Upset rivet by pressing handles together.

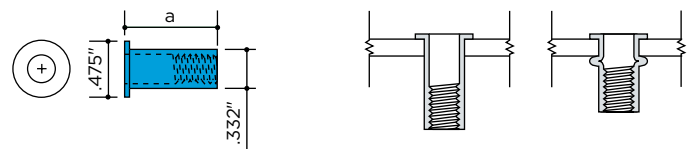

| | a | |
|--------------------|-------|--------------------------------|
| ● A25-140 Aluminum | .745" | Use with schedule 5 or 10 pipe |
| ● A25-200 Aluminum | .808" | Use with schedule 40 pipe |

The internally threaded tubular rivet is easily set in Connectorail® pipe wall. The rivet provides high-strength ¼"- 20 threads for blind attachment of Connectorail® tee fittings.

SEMS SCREWS AND THROUGH BOLT

● Stainless Steel



SEMS Screw
RHMS ¼"- 20 x 1"
with lock washer



RHMS ¼"- 20 x 2 ½" or 3"
with lock nut

SEMS Screws: SEMS Screws prevent accidental omission of lock washers and subsequent loosening of joints. The combination of ¼"- 20 x 1" stainless steel RHMS with lock washers and internally threaded tubular rivet fasteners provides connections of ample strength to develop the full loading capacity of Connectorail® pipe.

Through Bolts: Where two 90° tees are mounted opposite each other to form a cross assembly, a stainless steel through bolt with lock nut may be used.

For 1¼" pipe, use ¼"-20 x 2 ½" RHMS with lock nut.

For 1½" pipe, use ¼"-20 x 3" RHMS with lock nut.

SLEEVE ANCHOR BOLT

● ¾" x 3" Steel



GSA Spec. FF-S-325, 3.2.2.3.1.2

The **Sleeve Anchor Bolt** is an all steel, rust-proofed, multi-purpose anchor bolt intended for use in a wide range of masonry materials. The ¾" bolt is recommended for use with **Heavy-Duty Floor Flanges**.

● ALUMINUM ● BRONZE ● NICKEL-SILVER ● STAINLESS

Aluminum brackets are available with a mill finish or a clear anodized finish—AA-M32-C22-A31 (204R1). When designating clear anodized brackets, add the suffix -A to catalog number listed (e.g. 322-A).

POST BRACKETS

Satin Finish

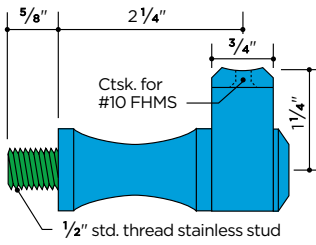

● 322 Aluminum

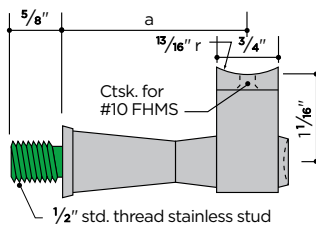

| | For use with pipe railings | a | b |
|--------|----------------------------|--------|----------|
| ● 402 | Aluminum | 2 1/4" | 1 5/8" |
| ● 402L | Aluminum | 2 1/2" | 1 5/8" |
| ● 404 | Aluminum | 2 3/4" | 1 5/8" |
| ● 802 | Bronze | 2 1/4" | 1 5/8" |
| ● 1302 | Nickel-Silver | 2 1/4" | 1 5/8" |
| ● 222 | Stainless | 2 1/4" | 1 13/16" |
| ● 222L | Stainless | 2 1/2" | 1 5/8" |

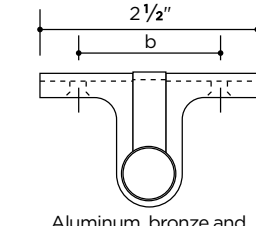
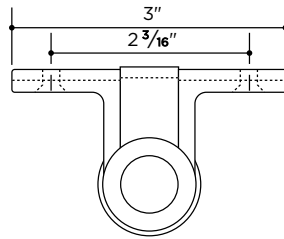

Aluminum, bronze and nickel-silver detail

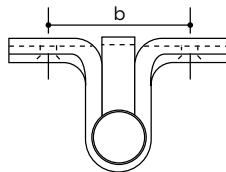

Stainless detail

BRACKET POST ADAPTERS

Satin Finish

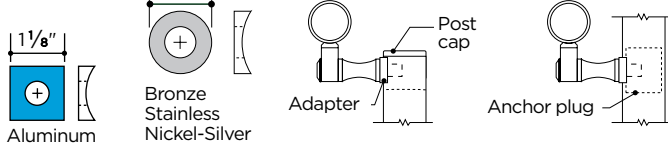

| | | Pipe Size | Schedule | Clear Hole |
|--------|---------------|-----------|----------|------------|
| ● 7161 | Aluminum | 1 1/4" | all | 1/2" |
| ● 7261 | Aluminum | 1 1/2" | all | 1/2" |
| ● 8661 | Bronze | 1 1/4" | all | 1/2" |
| ● 8861 | Bronze | 1 1/2" | all | 1/2" |
| ● 1361 | Nickel-Silver | 1 1/2" | all | 1/2" |
| ● 9161 | Stainless | 1 1/4" | all | 1/2" |
| ● 9361 | Stainless | 1 1/2" | all | 1/2" |

ANCHOR PLUGS

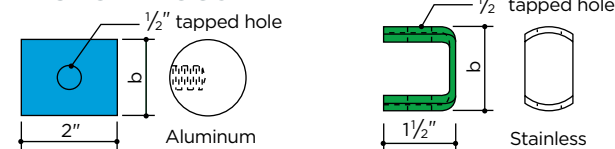

| | | Pipe Size | Schedule | b |
|--------|-----------|-----------|----------|--------|
| ● 7162 | Aluminum | 1 1/4" | 10 | 1.427" |
| ● 7462 | Aluminum | 1 1/4" | 40 | 1.360" |
| ● 7262 | Aluminum | 1 1/2" | 10 | 1.667" |
| ● 7562 | Aluminum | 1 1/2" | 40 | 1.585" |
| ● 9362 | Stainless | 1 1/2" | 5 | 1.750" |

Anchor plugs provide secure mounting for brackets supporting intermediate rails. Aluminum anchor plugs are machined from solid extruded stock; the stainless steel anchor plug is fabricated from heavy metal.

TWO-PIECE MOUNTING BRACKETS

Satin Finish

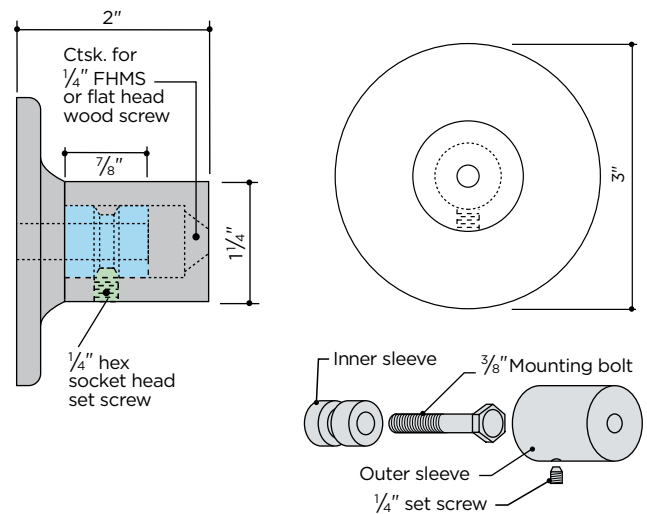

● 168 Aluminum
● 898 Bronze
● 298 Stainless

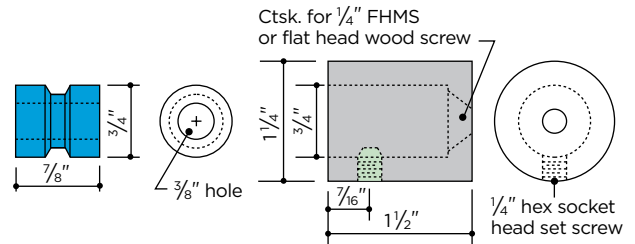

For elevator car handrails

● 166 Aluminum
● 896 Bronze
● 196 Nickel-Silver
● 296 Stainless

ADAPTERS

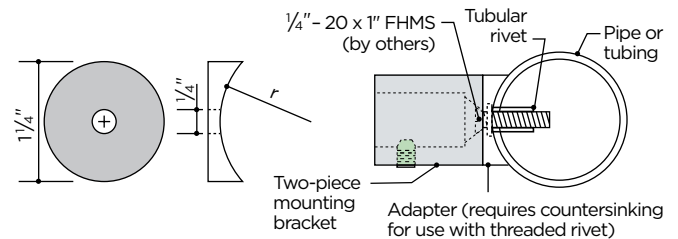

| | | r | Use With |
|--------|---------------|-------|-----------|
| ● 7164 | Aluminum | .830" | 1.660" OD |
| ● 7264 | Aluminum | .950" | 1.900" OD |
| ● 8864 | Bronze | .950" | 1.900" OD |
| ● 8964 | Bronze | .750" | 1.500" OD |
| ● 5264 | Nickel-Silver | .750" | 1.500" OD |
| ● 5364 | Nickel-Silver | .950" | 1.900" OD |
| ● 9164 | Stainless | .830" | 1.660" OD |
| ● 9364 | Stainless | .950" | 1.900" OD |

● ALUMINUM ● BRONZE ● NICKEL-SILVER ● STAINLESS

Aluminum brackets are available with a mill finish or a clear anodized finish—AA-M32-C22-A31 (204R1). When designating clear anodized brackets, add the suffix -A to catalog number listed (e.g. 307-A).

SELF-ALIGNING

Satin Finish, except as noted

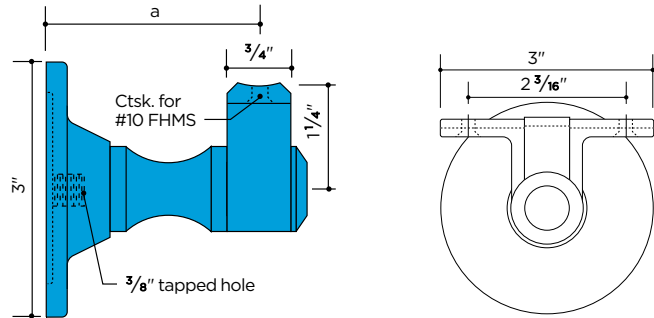

| | a |
|----------------|--------|
| ● 307 Aluminum | 2 1/2" |
| ● 308 Aluminum | 3" |

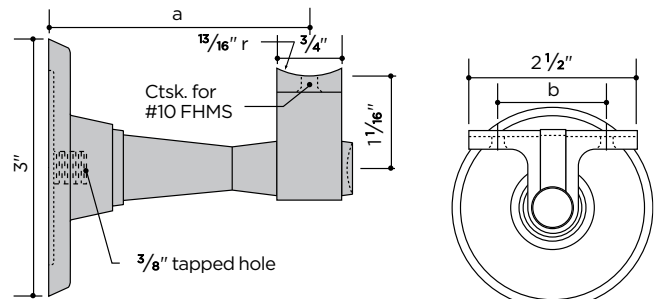

| | a | b |
|-----------------------|--------|----------|
| ● 321 Aluminum | 2 1/4" | 1 5/8" |
| ● 403 Aluminum | 3" | 1 5/8" |
| ● 405 Aluminum | 3 1/2" | 1 5/8" |
| ● 842* Bronze | 2 1/4" | 1 5/8" |
| ● 801* Bronze | 2 1/2" | 1 5/8" |
| ● 803* Bronze | 3" | 1 5/8" |
| ● 1303* Nickel-Silver | 3" | 1 5/8" |
| ● 1342* Nickel-Silver | 2 1/4" | 1 5/8" |
| ● 242 Stainless | 2 1/4" | 1 13/16" |
| ● 221 Stainless | 2 1/2" | 1 13/16" |
| ● 223 Stainless | 3" | 1 13/16" |

*Lacquered

EXTRUDED-UNPOLISHED

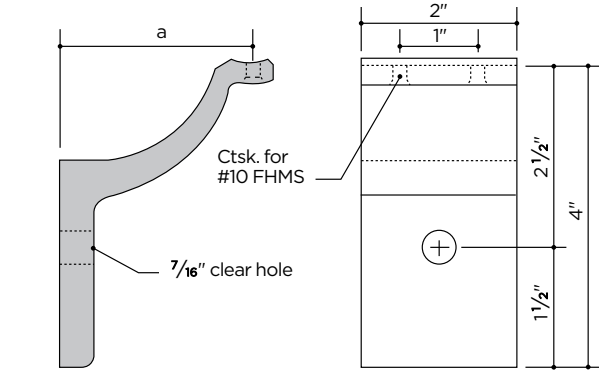

| | a |
|---------------------|--------|
| ● 478 Aluminum | 2 1/2" |
| ● 498 Aluminum | 3" |
| ● 892 Bronze | 2 1/2" |
| ● 894 Bronze | 3" |
| ● 192 Nickel-Silver | 2 1/2" |
| ● 218† Stainless | 2 1/2" |
| ● 220† Stainless | 3" |

† Satin Finish

CAST

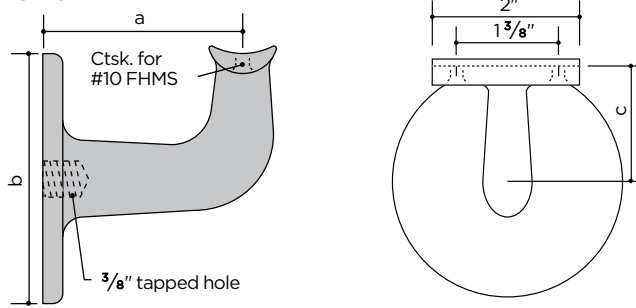

| | a | b | c |
|----------------------|--------|--------|---------|
| ● 376 Aluminum | 2 1/2" | 3 1/8" | 1 9/16" |
| ● 389 Aluminum | 3 1/8" | 3 3/4" | 1 7/8" |
| ● 375* Bronze | 2 1/2" | 3 1/8" | 1 9/16" |
| ● 319* Bronze | 3 1/8" | 3 3/4" | 1 7/8" |
| ● 176* Nickel-Silver | 2 1/2" | 3 1/8" | 1 9/16" |
| ● 275 Stainless | 2 1/2" | 3 1/8" | 1 9/16" |

STAMPED

Burnished Finish

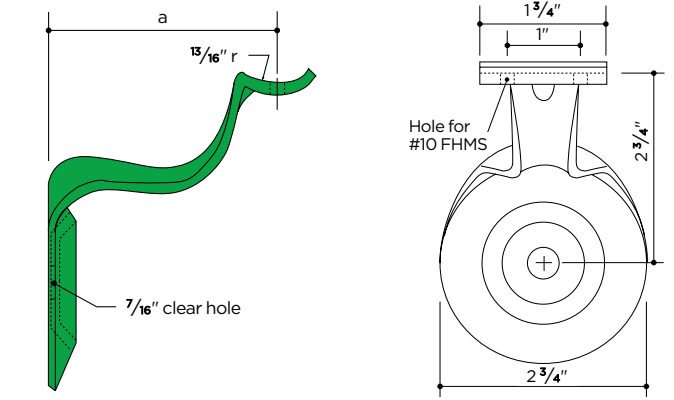

| | a |
|------------------|--------|
| ● 1022 Stainless | 2 1/2" |
| ● 1026 Stainless | 3" |

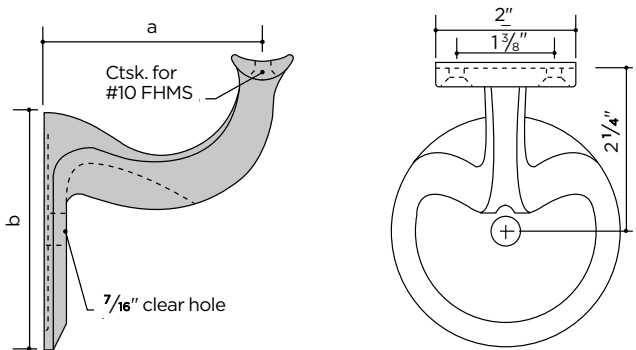

| | a | b |
|------------------|--------|--------|
| ● 384 Aluminum | 2 1/2" | 2 3/4" |
| ● 316 Aluminum | 3" | 3 1/4" |
| ● 388* Bronze | 2 1/2" | 2 3/4" |
| ● 318* Bronze | 3" | 3 1/4" |
| ● 1088 Stainless | 2 1/2" | 2 3/4" |

*Lacquered

CENTER POST BRACKETS

Mill Finish

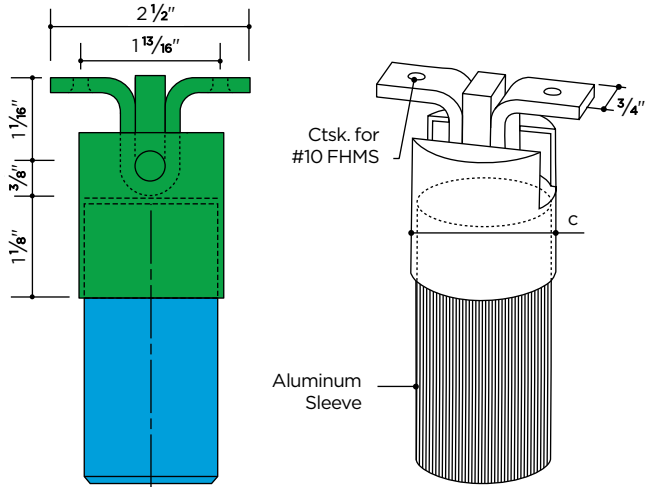

For center mounting of flat-bottomed handrail moulding onto stainless Connectorail® posts

| Flat | Pipe | Sched. | c |
|-----------------------|--------|--------|--------|
| ● 207 Stainless Steel | 1 1/2" | 5 | 1.900" |

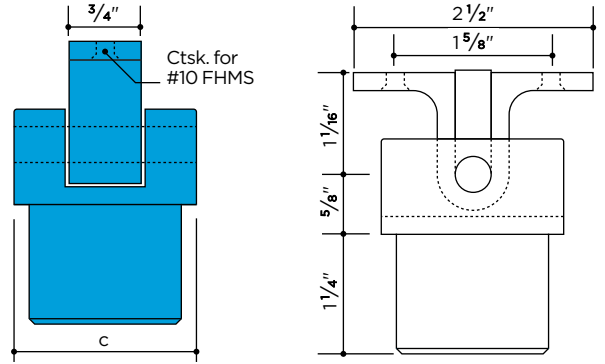

For center mounting of flat-bottomed handrail onto aluminum Connectorail® posts

| Flat | Pipe | Sched. | c |
|----------------|--------|--------|--------|
| ● 144 Aluminum | 1 1/4" | 40 | 1.660" |
| ● 145 Aluminum | 1 1/2" | 40 | 1.900" |

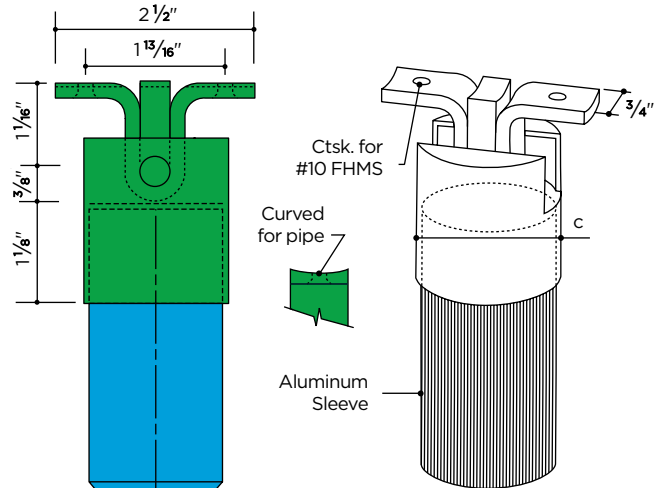

For center mounting of handrail pipe or rounded handrail onto stainless Connectorail® posts

| Curved | Pipe | Sched. | c |
|-----------------------|--------|--------|--------|
| ● 208 Stainless Steel | 1 1/2" | 5 | 1.900" |

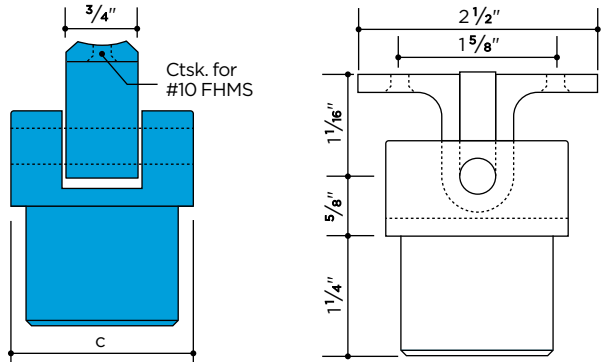

For center mounting of pipe or rounded handrail onto aluminum Connectorail® posts

| Curved | Pipe | Sched. | c |
|-----------------|--------|--------|--------|
| ● 142* Aluminum | 1 1/4" | 40 | 1.660" |
| ● 143* Aluminum | 1 1/2" | 40 | 1.900" |

* Also available in clear anodized AA-M32-C22-A31 (204R1)



Weldon E Howitt School, Farmingdale, NY, Hamilton Metal Works, Westbury, NY (Fabricator).

Assembly Details

Angle may be adjusted as required

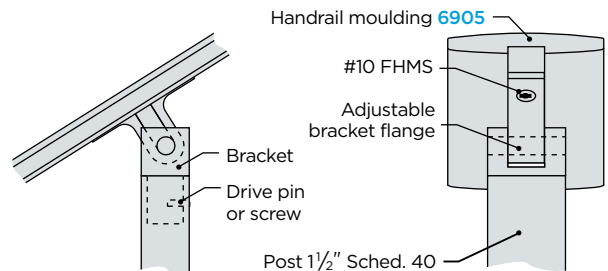

Verify all dimensions before cutting.

● ALUMINUM ● BRONZE ● NICKEL-SILVER ● STAINLESS ● PVC

INSTALLATION OF PICKET RAILS

Most current safety codes require reduced openings in railings where they might present a hazard to small children. Pipe railings, including the Connectorail® System, are easily adapted to comply with this requirement, where it applies, by adding balusters or panels. Typical details are shown on this page.

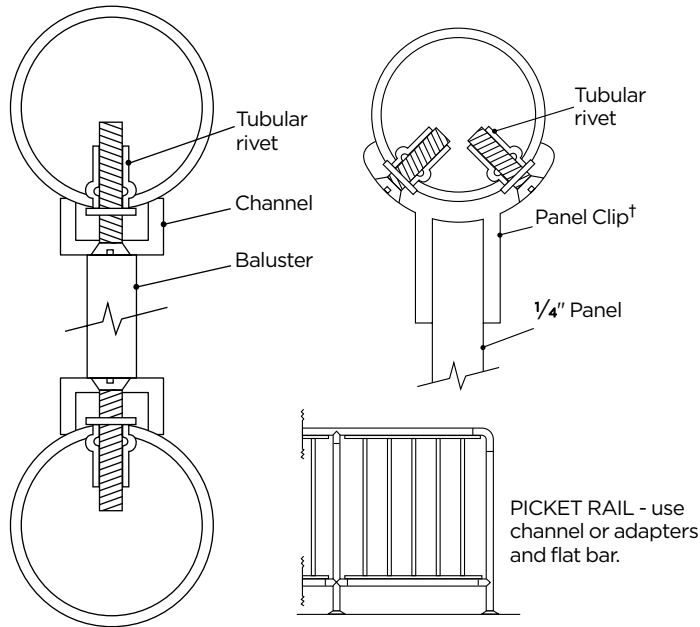

| †Panel Clip—Aluminum only | 1 1/4" Pipe | 1 1/2" Pipe |
|---------------------------|-------------|-------------|
| ● Aluminum | 7160* | 7260* |
| ● Aluminum | 7460 | 7560 |

* Two-piece panel clips, see below

PANEL CLIPS

For aluminum pipe only

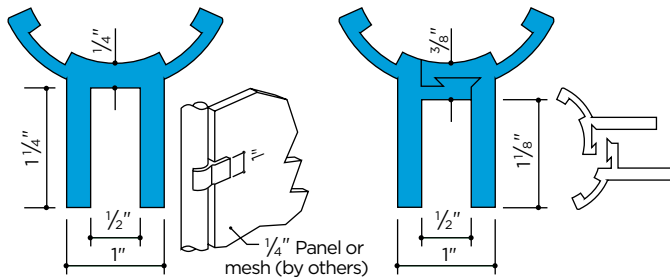

| | Pipe | Packages of 4 sets | Pipe |
|-----------|-----------------|--------------------|-----------------|
| ● 7460-5* | Aluminum 1 1/4" | ● 7260** | Aluminum 1 1/2" |
| ● 7460† | Aluminum 1 1/4" | | |
| ● 7560-5* | Aluminum 1 1/2" | | |
| ● 7560† | Aluminum 1 1/2" | | |

† Packages of 4 pieces

* 5' Length

** Two-piece assembly

INSTALLATION OF PANEL RAILS

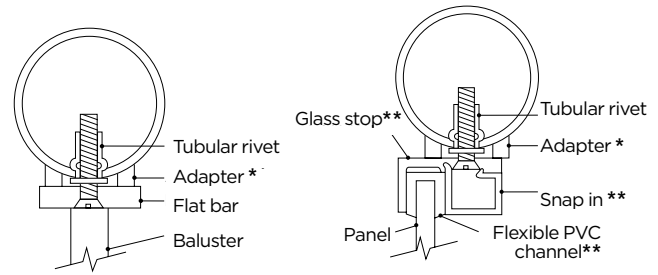

| * Adapters | 1 1/4" Pipe | 1 1/2" Pipe |
|-------------|-------------|-------------|
| ● Aluminum | 7161 | 7261 |
| ● Bronze | 8661 | 8861 |
| ● Stainless | 9161 | 9361 |

| ** Glass Stop | Glass Stop | Snap-in |
|-------------------------|------------|---------|
| ● Aluminum, Mill Finish | 8106 | 8107 |
| ● Aluminum, Anodized | 8206 | 8207 |
| ● Bronze | 4506 | 4507 |
| ● Flexible PVC | 8708 | |

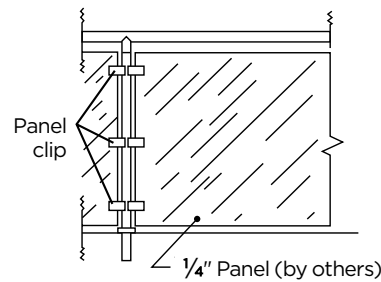

PANEL CLIPS

For mounting to flat surface, Satin Finish

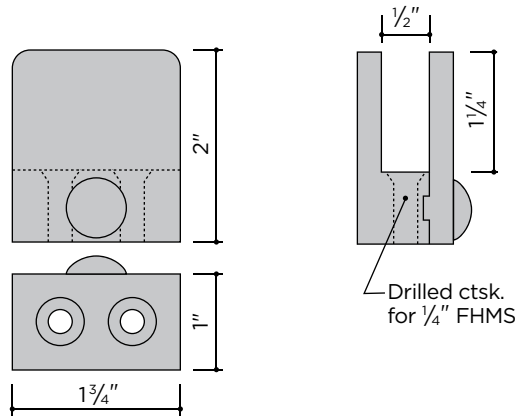

| | | | |
|-------|----------|-------|---------------|
| ● 113 | Aluminum | ● 413 | Nickel-Silver |
| ● 813 | Bronze | ● 213 | Stainless |

Plug (packed separately) is inserted following installation and may be held in place with epoxy or other sealant.

SPECIAL CHARACTERISTICS

Connectorail® is a pre-engineered pipe railing system with pre-fabricated components. It is fabricated with ordinary tools and without welding. It is designed to meet established safety standards.

The structural integrity of the railing system depends on proper selection of components, proper number and location of supports, and correct assembly and installation. The data and instructions in this catalog make it easy to meet these conditions (see engineering data on pages 122-129). Most fittings are dimensioned in whole inches to facilitate layout. Confirm dimensions prior to cutting and assembly.

POSTS

High-strength posts and the use of reinforcing inserts are recommended to permit longer spans and to comply with the most stringent loading requirements. Fascia Flanges and Heavy-Duty Floor Flanges include reinforcing inserts. Refer to page 129 for post spacing tables.

EXPANSION JOINTS

Expansion joints should be provided for continuous runs in excess of 40' or at places where building structure provides expansion joints. If a joint is provided every 20', the width of the gap should allow $\frac{1}{8}$ " expansion for each 40°F of expected temperature rise. To make an expansion joint, the internal connector sleeve is left unattached at one end so that it is free to move in and out of the pipe.

SPLICE JOINTS

Splice joints are secured by internal connector sleeves with the use of epoxy adhesive. Connector sleeves must be ordered separately unless a sleeve is already welded into the fitting, as it is in tees, wall returns, and miter elbows. Sleeves are made for a tight press fit and must be compressed with pliers or "C" clamps to permit them to slip into the pipe. Care must be taken to keep the sleeves round. Pipe ends must be cut square and to accurate length to assure smooth, tight joints.

The areas to be joined should be cleaned thoroughly. The adhesive is mixed according to manufacturer's directions. Do not mix more than you can use within 1/2 hour. Apply adhesive to inside of pipe. Fit components together and wipe off excess adhesive. Leave undisturbed for eight hours—longer in cold weather.

All splices should be made as near as possible to a post, in no event more than 12" from the nearest post.

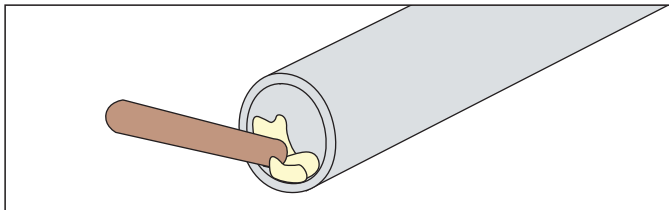

Apply adhesive to inside of pipe.

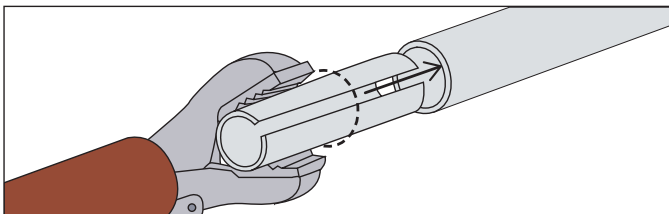

About one half of the 5"-long sleeve should be inside each of the pipe ends.

TEE FITTINGS

Tee fittings are secured to the post or rail by means of an internally threaded tubular rivet inserted into the wall of the pipe and a stainless steel machine screw and lock washer. When two 90° tees are mounted directly opposite each other to form a cross, a stainless steel through bolt and lock nut may be used.

Drill pipe with drill size Q or $\frac{11}{32}$ " hole. Screw a rivet sleeve-side first onto the mandrel of the tool. Hold the tool in one hand. Using the tool, insert the rivet into the hole until the tool comes to rest against the parent material. Upset rivet by pressing handles together.

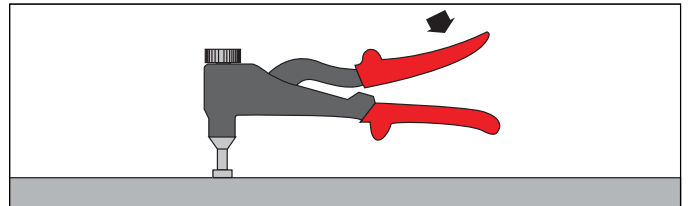

Set tubular rivet in hole, using setting tool. Upset rivet by pressing handles together.

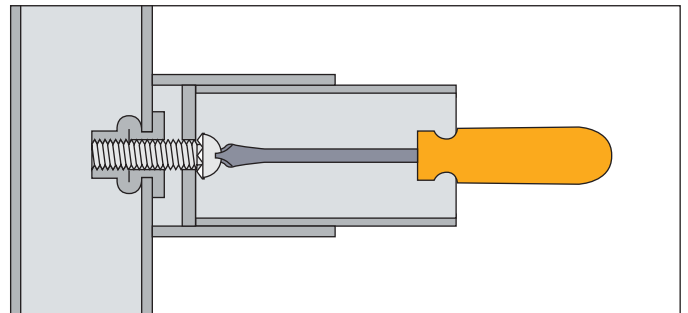

Draw the fitting up tight with a stainless steel screw and lock washer.

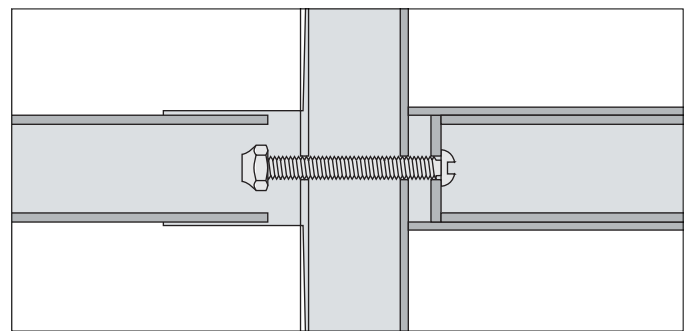

Draw the fittings up tightly from both sides, using a stainless steel lock nut.

The use of a lock washer or lock nut is essential because the assembly must remain tight once it is completed. There is no way to re-tighten an assembled railing. Stainless steel screws are required because they provide maximum strength. The 1"-long screws are supplied with the lock washer already in place.

To locate holes to be drilled for angle tees and crosses, request our drilling template or make your own template as follows: Draw a rectangle of a width equal to the circumference of the pipe (5.21" for $\frac{1}{4}$ " pipe, 5.97" for $\frac{1}{2}$ " pipe), about 3" to 4" high.

ANGLED TEE FITTINGS

Draw the horizontal and vertical center lines. Draw two more vertical lines at half the distance between center line and edges of the rectangle. On the new lines, mark 1" above and below the horizontal center line. Wrap the template around the post so that its horizontal center line is on a level with the intersection of center lines of the post and the rail. The marks on the template will indicate the location of holes.

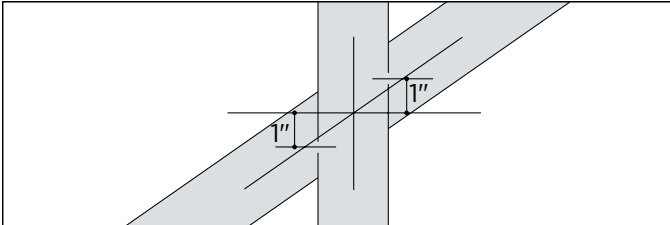

Holes for angle tees, except 4° ramp tee, are located 1" above and below intersection of center lines of pipe, regardless of stair angle.

MOUNTING POSTS

Embedding in concrete: Posts embedded in concrete should be set to a depth of 5" below the surface of the floor or tread. Allow for a 1" grout pad beneath post. Provide a hole 2 1/2" to 3" in diameter to leave room for grouting cement and to allow for adjustment to field variations. A quick-setting grout is recommended for setting posts. For outdoor installation, weep holes should be drilled in the posts just above the ground. The reinforcing insert will prevent water from collecting below ground level. Where aluminum surfaces are embedded in concrete that contains corrosive components, a coat of zinc chromate primer or equivalent must be applied.

Surface Mounting: Sleeve anchor bolt 3/8" x 3" is recommended for use with heavy-duty floor flange. Drill 3/8" hole in concrete or masonry to 3" depth. Drill holes which conform to ANSI standard carbide bit dimension (.390" to .398"). Clean out dust in hole after drilling. Insert sleeve bolt in hole, hand tighten, then tighten with wrench to a maximum torque of 30 ft. lbs. Use heavy-duty floor flange as a template for locating holes. Minimum distance from centerline of hole to edge of concrete is 2".

Fascia Mounting: Disassemble the fascia flange, which includes a reinforcing bar, by removing two screws from the back of the plate. Drill two 7/16" holes in the post, one hole 1 1/4" from the lower end, the second one 4" on center from the first, so that they align with holes in the reinforcing insert. The reinforcing insert is slipped inside the post, and the unit is reassembled and mounted, using 3/8" bolts. While the unit is disassembled, the plate of the fascia flange may be used as a template to locate the holes for mounting the flange.

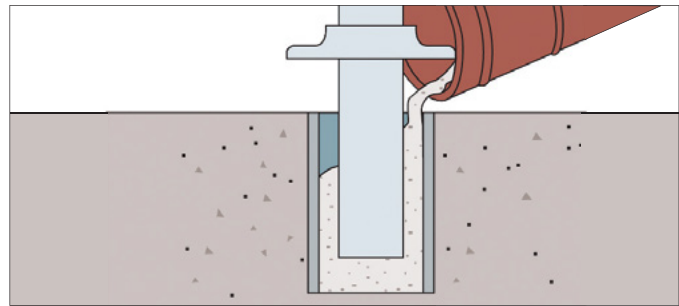

Use reinforcing bar and cover flange. Drill weep hole 1/4" above cover flange. Apply zinc chromate primer or equivalent to surfaces embedded in concrete. Set in floor to a depth of 5" and grout.

For outdoor installation of aluminum, the metal must be kept from direct contact with concrete or dissimilar metal by application of bituminous paint or methacrylate lacquer.

ANODIZED FINISHES

When clear anodized components are supplied, no further finishing is necessary. Any other specified finishes are the fabricator's responsibility and components will be supplied with mill finish only.

All stainless steel fasteners must be removed before anodizing.



Weldon E. Howitt School, Farmingdale, NY, Hamilton Metalcraft, Westbury, NY (Fabricator).

● ALUMINUM ● BRONZE ● NICKEL-SILVER ● STAINLESS ● MALLEABLE IRON / STEEL

CAST FLUSH FITTINGS FOR WELDED ASSEMBLY

Stainless fittings are furnished with a satin finish. Aluminum components are 6063 alloy, mill finish. Cast aluminum components are Almag 35. Satin finish. Cast bronze fittings are lacquered bronze alloy (C86500), which matches the color of red brass (C23000) satin finish. Cast nickel-silver components are lacquered nickel-silver alloy, which matches the color of nickel-silver (C79800), satin finish. Cast iron fittings are cast to match carbon steel (C1010). Fittings shown are made to fit standard pipe sizes.

See pages 16 through 24 for other non-ferrous pipe fittings for 1 1/4" and 1 1/2" pipe.

PIPE COVER FLANGE

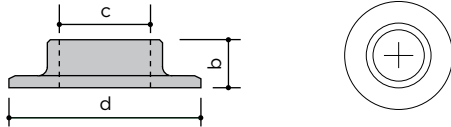

| | | Pipe | Sched. | b | c | d |
|--------|-----------------|--------|--------|-------|-------|--------|
| ● 714 | Aluminum | 1" | all | .813" | 1.34" | 3.625" |
| ● 710 | Aluminum | 1 1/4" | all | 1" | 1.69" | 3.813" |
| ● 711 | Aluminum | 1 1/2" | all | 1" | 1.94" | 4" |
| ● 712 | Aluminum | 2" | all | 1" | 2.41" | 5" |
| ● 810 | Bronze | 1 1/4" | all | 1" | 1.69" | 3.810" |
| ● 811 | Bronze | 1 1/2" | all | 1" | 1.94" | 4" |
| ● 411 | Nickel-Silver | 1 1/2" | all | 1" | 1.94" | 4" |
| ● 214 | Stainless | 1" | all | 7/8" | 1.34" | 3.750" |
| ● 210 | Stainless | 1 1/4" | all | 7/8" | 1.69" | 3.750" |
| ● 211 | Stainless | 1 1/2" | all | 7/8" | 1.94" | 4.500" |
| ● 913 | Pressed Steel | 3/4" | all | 3/4" | 1.08" | 3.500" |
| ● 914 | Pressed Steel | 1" | all | 7/8" | 1.34" | 3.750" |
| ● 910 | Pressed Steel | 1 1/4" | all | 7/8" | 1.69" | 3.750" |
| ● 911 | Pressed Steel | 1 1/2" | all | 7/8" | 1.94" | 4.500" |
| ● 912 | Pressed Steel | 2" | all | 7/8" | 2.41" | 4.750" |
| ● 614 | Cast Iron/Black | 1" | all | .813" | 1.34" | 3.625" |
| ● 610 | Cast Iron/Black | 1 1/4" | all | .813" | 1.69" | 3.875" |
| ● 611 | Cast Iron/Black | 1 1/2" | all | .813" | 1.94" | 4.188" |
| ● 612 | Cast Iron/Black | 2" | all | .813" | 2.41" | 4.625" |
| ● 1614 | Cast Iron/Galv. | 1" | all | .813" | 1.34" | 3.625" |
| ● 1610 | Cast Iron/Galv. | 1 1/4" | all | .813" | 1.69" | 3.875" |
| ● 1611 | Cast Iron/Galv. | 1 1/2" | all | .813" | 1.94" | 4.188" |
| ● 1612 | Cast Iron/Galv. | 2" | all | .813" | 2.41" | 4.625" |

90° ELBOWS

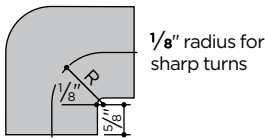

| | | Pipe | R |
|--------|-----------|--------|--------|
| ● 958 | Steel | 1 1/4" | 15/16" |
| ● 959 | Steel | 1 1/2" | 11/16" |
| ● 258* | Stainless | 1 1/4" | 15/16" |
| ● 259* | Stainless | 1 1/2" | 11/16" |

* Satin Finish

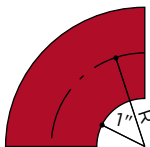

| | | Pipe | R |
|-------|-------|--------|----------|
| ● 917 | Steel | 1" | 11 1/16" |
| ● 918 | Steel | 1 1/4" | 13 1/16" |
| ● 919 | Steel | 1 1/2" | 15 1/16" |
| ● 920 | Steel | 2" | 23 1/16" |

FITTINGS FOR WELDED ASSEMBLY

All fittings are for IPS Schedule 40 pipe, except as noted.

TEES

In welded railings, no fittings are used for tee and cross connections. The ends of the pipe are notched with a special tool known as the Arc Fit Pipe Notcher to match the contour of the pipe to be joined. The joint is then welded.

90° ELBOWS

Detail showing 1 5/8" radius 90° elbow as wall return

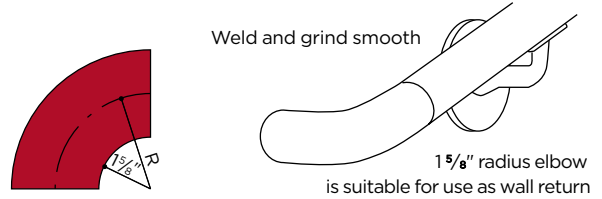

| | | Pipe | R |
|-------|-------|--------|--------|
| ● 948 | Steel | 1 1/4" | 27/16" |
| ● 949 | Steel | 1 1/2" | 29/16" |

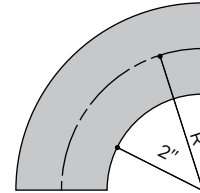

| | | Pipe | R |
|--------|-----------|--------|----------|
| ● 232* | Stainless | 1" | 2 11/16" |
| ● 225* | Stainless | 1 1/4" | 2 13/16" |
| ● 226* | Stainless | 1 1/2" | 2 15/16" |
| ● 915 | Steel | 1" | 2 11/16" |
| ● 925 | Steel | 1 1/4" | 2 13/16" |
| ● 926 | Steel | 1 1/2" | 2 15/16" |

* Satin Finish

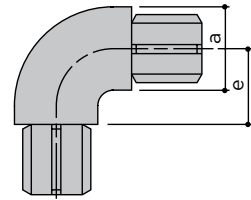

| Black | Galv. | | Pipe | a | e |
|--------|-------|----------------|--------|----------|--------|
| ● 618 | 1618 | Malleable Iron | 1 1/4" | 1 21/32" | 1 1/4" |
| ● 619 | 1619 | Malleable Iron | 1 1/2" | 1 29/32" | 1 1/2" |
| ● 620 | | Malleable Iron | 2" | 2 3/8" | 1 7/8" |
| ● 720* | | Aluminum | 2" | 2 3/8" | 1 7/8" |

* Satin Finish

OVAL POST FLANGES

Flour

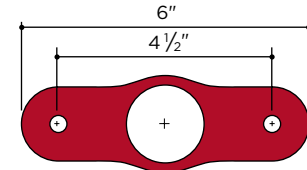

Angle

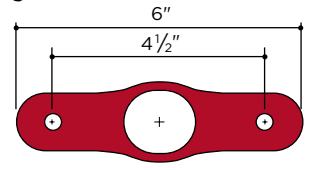

| | | Pipe | | Pipe | |
|-------|-------|--------|-------|-------|--------|
| ● 927 | Steel | 1 1/4" | ● 942 | Steel | 1 1/4" |
| ● 928 | Steel | 1 1/2" | ● 943 | Steel | 1 1/2" |

● ALUMINUM ● BRONZE ● STAINLESS ● MALLEABLE IRON / STEEL

FITTINGS FOR WELDED ASSEMBLY

All fittings are for IPS Schedule 40 pipe, except as noted.



90° THREE-WAY ELBOW



For corner posts

| | Pipe | r | R |
|-------------|--------|------|---------|
| ● 903 Steel | 1 1/4" | 1/8" | 5/16" |
| ● 904 Steel | 1 1/2" | 1/8" | 1 1/16" |

45° ELBOWS

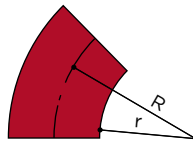

| | Pipe | r | R |
|-------------|--------|----|----------|
| ● 929 Steel | 1" | 1" | 1 11/16" |
| ● 930 Steel | 1 1/4" | 1" | 1 13/16" |
| ● 933 Steel | 1 1/4" | 2" | 2 13/16" |
| ● 931 Steel | 1 1/2" | 1" | 1 15/16" |
| ● 934 Steel | 1 1/2" | 2" | 2 15/16" |
| ● 932 Steel | 2" | 1" | 2 3/16" |

DRIVE-ON CAPS

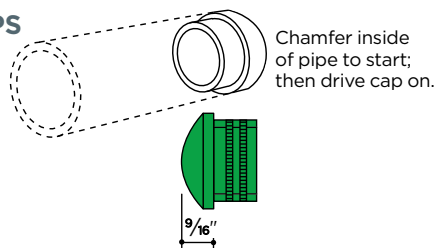

Chamfer inside of pipe to start; then drive cap on.

| | Pipe | m | | Pipe |
|-------------|--------|--------|------------------|----------------|
| ● 906 Steel | 1" | 1" | ● 212* Stainless | 1" |
| ● 907 Steel | 1 1/4" | 1 1/8" | ● 277* Stainless | 1 1/4" |
| ● 908 Steel | 1 1/2" | 1 1/4" | ● 278* Stainless | 1 1/2" |
| ● 909 Steel | 2" | 1 3/8" | | * Satin Finish |

END CAPS

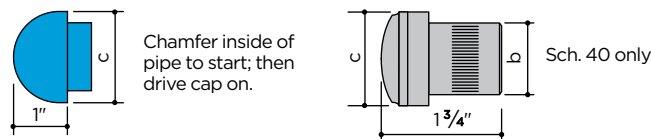

Chamfer inside of pipe to start; then drive cap on.

| | Pipe | Sched. | c | | Pipe | b | c |
|------------|--------|--------|--------|------------|--------|------|--------|
| ● 7181 Al. | 1 1/4" | 10 | 1.660" | ● 707* Al. | 1 1/4" | 1.38 | 1.660" |
| ● 7481 Al. | 1 1/4" | 40 | 1.660" | ● 708* Al. | 1 1/2" | 1.61 | 1.900" |
| ● 7281 Al. | 1 1/2" | 10 | 1.900" | ● 807* Br. | 1 1/4" | 1.37 | 1.660" |
| ● 7581 Al. | 1 1/2" | 40 | 1.900" | ● 808* Br. | 1 1/2" | 1.60 | 1.900" |

* Satin Finish

WALL RETURN

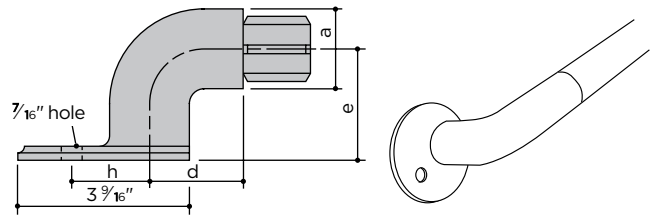

For schedule 40 pipe

| Black | Galv. | Pipe | a | d | h | e |
|-------|----------------|--------|----------|----------|----------|--------|
| ● 604 | 1604 Cast Iron | 1 1/4" | 1 21/32" | 1 15/16" | 1 5/8" | 2 1/2" |
| ● 664 | 1664 Cast Iron | 1 1/4" | 1 21/32" | 1 15/16" | 1 5/8" | 3" |
| ● 605 | 1605 Cast Iron | 1 1/2" | 1 29/32" | 2 1/16" | 1 11/16" | 2 1/2" |
| ● 665 | 1665 Cast Iron | 1 1/2" | 1 29/32" | 2 1/16" | 1 11/16" | 3" |

For light wall structural pipe schedule 10

| | | | | | | |
|--------|-----------|--------|----------|----------|----------|--------|
| ● 3604 | Cast Iron | 1 1/4" | 1 21/32" | 1 15/16" | 1 5/8" | 2 1/2" |
| ● 3605 | Cast Iron | 1 1/2" | 1 29/32" | 2 1/16" | 1 11/16" | 2 1/2" |

For schedule 40 pipe

| | | | | | | |
|--------|----------|--------|----------|----------|----------|--------|
| ● 705* | Aluminum | 1 1/2" | 1 29/32" | 2 1/16" | 1 11/16" | 2 1/2" |
| ● 759* | Aluminum | 1 1/4" | 1 21/32" | 1 15/16" | 1 5/8" | 3" |

* Satin Finish

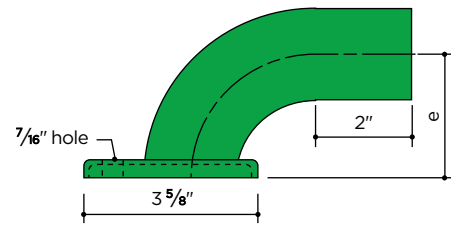

Schedule 40 pipe return and 1/8" formed flange are joined by a concealed weld.

| | Pipe | e |
|-------------------|--------|--------|
| ● 215F* Stainless | 1 1/4" | 2 1/2" |
| ● 216F* Stainless | 1 1/2" | 2 1/2" |

* Satin Finish

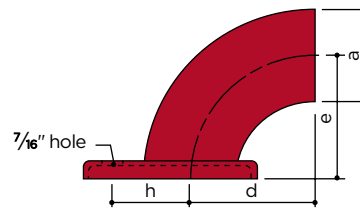

| | Pipe | a | d | h | e |
|-------------|--------|----------|----------|----------|--------|
| ● 983 Steel | 1 1/4" | 1 21/32" | 2 7/16" | 1 5/8" | 2 1/2" |
| ● 984 Steel | 1 1/4" | 1 21/32" | 2 13/16" | 1 5/8" | 3" |
| ● 985 Steel | 1 1/2" | 1 29/32" | 2 1/4" | 1 15/32" | 2 1/2" |
| ● 986 Steel | 1 1/2" | 1 29/32" | 2 15/16" | 1 15/32" | 3" |

POST BRACKET

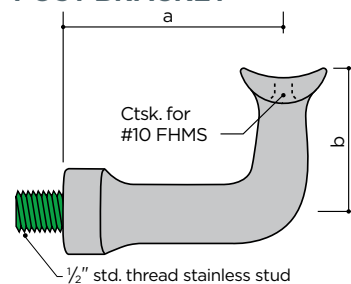

1/2" std. thread stainless stud

| | a | b |
|-----------------|--------|---------|
| ● 373 Aluminum | 2 1/2" | 1 9/16" |
| ● 303 Bronze | 2 1/2" | 1 9/16" |
| ● 374 Mal. Iron | 2 1/2" | 1 9/16" |

• Post bracket adapter, pg. 94

PIPE RAILINGS

● ALUMINUM ● STAINLESS ● CAST IRON / MALLEABLE IRON / STEEL

FITTINGS FOR WELDED ASSEMBLY

All fittings are for IPS Schedule 40 pipe, except as noted.

WELD-ON CAPS

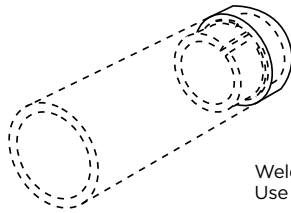
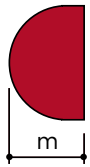

Weld and grind smooth.
Use of connector is optional.

| | | Pipe | m |
|-------|-------|--------|--------|
| ● 936 | Steel | 1" | 1" |
| ● 937 | Steel | 1 1/4" | 1 1/8" |
| ● 938 | Steel | 1 1/2" | 1 1/4" |
| ● 939 | Steel | 2" | 1 3/8" |

CONNECTOR

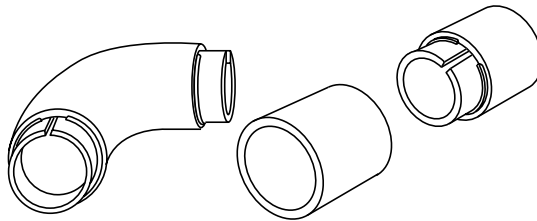
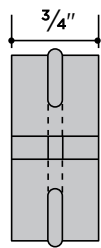

Connector snaps in place with a spring fit, holding elbow and pipe in position for welding.

| | | | Pipe |
|-------|-------|-------|------------------|
| ● 951 | Steel | ● 291 | Stainless 1" |
| ● 952 | Steel | ● 292 | Stainless 1 1/4" |
| ● 953 | Steel | ● 293 | Stainless 1 1/2" |
| ● 954 | Steel | | 2" |

SQUARE POST FITTING

Cast

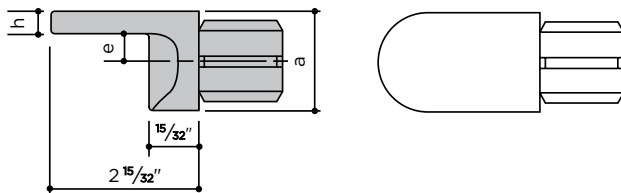

| For schedule 40 pipe | | Pipe | a | h | e |
|--------------------------------------------|----------------|--------|---------|-------|--------|
| ● 601 | Malleable Iron | 1 1/4" | 121/32" | 3/8" | 29/64" |
| ● 602 | Malleable Iron | 1 1/2" | 129/32" | 7/16" | 33/64" |
| For light wall structural pipe schedule 10 | | | | | |
| ● 3601 | Malleable Iron | 1 1/4" | 121/32" | 3/8" | 29/64" |
| ● 3602 | Malleable Iron | 1 1/2" | 129/32" | 7/16" | 33/64" |
| For schedule 40 pipe | | | | | |
| ● 701* | Aluminum | 1 1/4" | 121/32" | 3/8" | 29/64" |
| ● 702* | Aluminum | 1 1/2" | 129/32" | 7/16" | 33/64" |

* Satin Finish

PIPE SPLICE LOCK

A single allen screw locks the joint

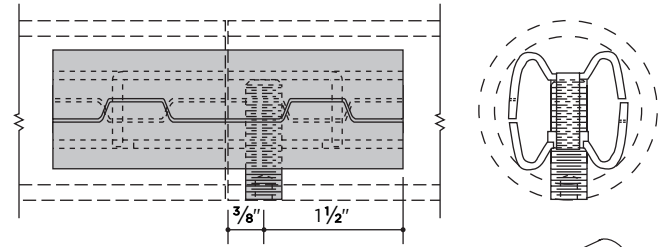

For quick, weldless end-to-end connection of pipe in the shop or in the field. Connections made with the pipe splice lock are flush, permanent, and in perfect alignment. Also suited for expansion joints.

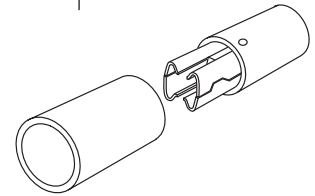

| For schedule 40 pipe | | | | For light wall structural pipe schedule 10 | |
|----------------------|-------------|-----------|-------|--------------------------------------------|---------------------|
| Steel | Galv. Steel | Stainless | Steel | Steel | Pipe |
| ● 921 | | ● 289 | | | 1" |
| ● 922 | ● 1922 | ● 287 | ● 901 | | 1 1/4" |
| ● 923 | ● 1923 | ● 288 | | | 1 1/2" |
| ● 924 | | | | | 2" |
| | | | | | For schedule 5 pipe |
| | | ● 286 | | | 1 1/4" |

PIPE PLUGS



| For schedule 40 pipe | | | For light wall structural pipe schedule 10 | |
|----------------------|-------|------------------|--------------------------------------------|------------------|
| Black | Galv. | Pipe | Black | Pipe |
| ● 606 | 1606 | Cast Iron 1" | ● 3607 | Cast Iron 1 1/4" |
| ● 607 | 1607 | Cast Iron 1 1/4" | ● 3608 | Cast Iron 1 1/2" |
| ● 608 | | Cast Iron 1 1/2" | | |
| ● 609 | 1609 | Cast Iron 2" | | |

SQUARE POST FITTING

Stamped Steel

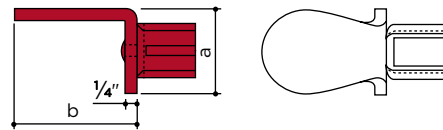

| For schedule 40 pipe | | Pipe | a | b |
|----------------------|----------------|--------|--------|--------|
| ● 987 | Malleable Iron | 1 1/4" | 1 5/8" | 2 5/8" |



Sun Valley Music Pavillion, Sun Valley, Idaho, Ruscitto/Latham/Blanton, Sun Valley, Idaho (Architect), Diversified Metal Products, Inc., Idaho Falls, Idaho (Fabricator).

● ALUMINUM ● BRONZE ● NICKEL-SILVER ● STAINLESS

OD ROUND TUBING

20' lengths, except as noted
Mill Finish only, except as noted

| | |
|-----------------|----------|
| ● Aluminum | 6063-T52 |
| ● Bronze | C38500 |
| ● Nickel-Silver | C79800 |
| ● Stainless | Type 304 |

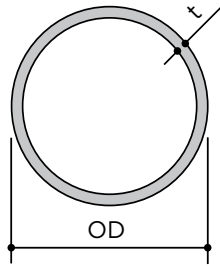

| | OD | t | lb/ft | Area | I | S |
|------------------|--------|-------|-------|-------|-------|-------|
| ● Aluminum | 1.900" | .109" | .721 | .614 | .247 | .260 |
| ● Aluminum | 2 1/2" | .125" | 1.119 | .933 | .659 | .527 |
| ● Aluminum | 3" | .125" | 1.328 | 1.129 | 1.169 | .779 |
| ● Aluminum | 3 1/2" | .125" | 1.559 | 1.325 | 1.890 | 1.080 |
| ● Bronze | 1.900" | .100" | 1.750 | .440 | .108 | .144 |
| ● Bronze | 1.900" | .100" | 2.070 | .565 | .230 | .242 |
| ● Bronze | 2 1/2" | .125" | 3.441 | .933 | .659 | .527 |
| ● Bronze | 3" | .125" | 4.500 | 1.129 | 1.169 | .779 |
| ● Bronze†† | 3 1/2" | .125" | 4.850 | 1.325 | 1.890 | 1.080 |
| ● Nickel-Silver | 1.900" | .100" | 1.750 | .440 | .108 | .144 |
| ● Nickel-Silver | 1.900" | .109" | 2.250 | .614 | .247 | .260 |
| ● Nickel-Silver† | 2 1/2" | .125" | 3.400 | .933 | .659 | .527 |
| ● Nickel-Silver† | 3" | .125" | 4.500 | 1.129 | 1.169 | .779 |
| ● Stainless** | 1.900" | .062" | 1.274 | .375 | .158 | .166 |
| ● Stainless | 2 1/2" | .062" | 1.691 | .479 | .356 | .285 |
| ● Stainless | 3" | .062" | 1.930 | .577 | .622 | .415 |
| ● Stainless | 4" | .062" | 2.550 | .804 | 1.556 | .778 |

** No. 4 Finish
† 16' lengths †† 12' lengths

END CAPS

Satin Finish, except as noted



| | | a | b |
|---------|---------------|------|--------|
| ● 7280* | Aluminum | 1/8" | 1.900" |
| ● 1180* | Aluminum | 1/8" | 2 1/2" |
| ● 1182* | Aluminum | 1/8" | 3" |
| ● 1181* | Aluminum | 1/8" | 3 1/2" |
| ● 1282 | Bronze | 1/4" | 1.900" |
| ● 1280 | Bronze | 1/4" | 2 1/2" |
| ● 1283 | Bronze | 1/4" | 3" |
| ● 1281 | Bronze | 1/4" | 3 1/2" |
| ● 6489N | Bronze | 1/4" | 1.500" |
| ● 6489D | Bronze | • | 1.500" |
| ● 5289N | Nickel-Silver | 1/4" | 1.500" |
| ● 1330N | Nickel-Silver | 1/4" | 1.900" |
| ● 1332N | Nickel-Silver | 1/4" | 2 1/2" |
| ● 1333N | Nickel-Silver | 1/4" | 3" |
| ● 9380 | Stainless | 1/8" | 1.900" |
| ● 1480 | Stainless | 1/8" | 2 1/2" |
| ● 1482 | Stainless | 1/8" | 3" |
| ● 1473N | Stainless | 1/8" | 4" |

* Mill Finish • Dome-shaped; extends 1" beyond end of tube.

COVER FLANGE

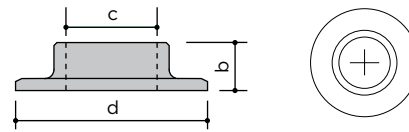

| | | OD | b | c | d |
|--------|---------------|--------|---------|-------|--------|
| ● 711 | Aluminum | 1.900" | 1" | 1.94" | 4" |
| ● 1125 | Aluminum | 2 1/2" | 1" | 2.54" | 4 3/4" |
| ● 1123 | Aluminum | 3" | 1" | 3.04" | 5" |
| ● 811 | Bronze | 1.900" | 1" | 1.94" | 4" |
| ● 1225 | Bronze | 2 1/2" | 1" | 2.54" | 4 3/4" |
| ● 1223 | Bronze | 3" | 1" | 3.04" | 5" |
| ● 411 | Nickel-Silver | 1.900" | 1" | 1.94" | 4" |
| ● 1325 | Nickel-Silver | 2 1/2" | 1" | 2.54" | 4 3/4" |
| ● 1323 | Nickel-Silver | 3" | 1" | 3.04" | 5" |
| ● 211 | Stainless | 1.900" | 7/8" | 1.94" | 4 1/2" |
| ● 1425 | Stainless | 2 1/2" | 1 1/16" | 2.54" | 4 7/8" |
| ● 1423 | Stainless | 3" | 1 7/16" | 3.04" | 6 1/8" |

90° RADIUS ELBOW

Satin Finish, except as noted

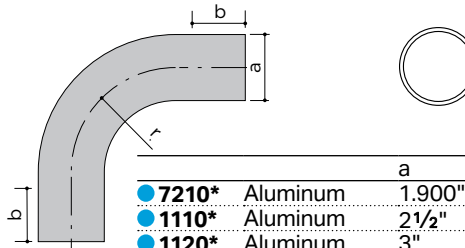

Elbow may be trimmed for use as wall return. For brackets, see pages 22-23.

| | | a | r | Wall | b |
|----------|---------------|--------|----|-------|--------|
| ● 7210* | Aluminum | 1.900" | 3" | .109" | 2" |
| ● 1110* | Aluminum | 2 1/2" | 5" | .125" | 2 1/2" |
| ● 1120* | Aluminum | 3" | 5" | .125" | 2 1/2" |
| ● 1122* | Aluminum | 3 1/2" | 5" | .125" | 2 1/2" |
| ● 1222* | Bronze | 1.900" | 3" | .100" | 2 1/2" |
| ● 1210* | Bronze | 2 1/2" | 5" | .125" | 2 1/2" |
| ● 1220* | Bronze | 3" | 6" | .125" | 2 1/2" |
| ● 6489C* | Bronze | 1.500" | 3" | .100" | 2 1/2" |
| ● 1330C* | Nickel-Silver | 1.900" | 3" | .109" | 2 1/2" |
| ● 1332C* | Nickel-Silver | 2 1/2" | 5" | .125" | 2 1/2" |
| ● 1333C* | Nickel-Silver | 3" | 5" | .125" | 2 1/2" |
| ● 9310 | Stainless | 1.900" | 3" | .062" | 2" |
| ● 1410 | Stainless | 2 1/2" | 5" | .062" | 2 1/2" |
| ● 1420 | Stainless | 3" | 5" | .062" | 2 1/2" |

* Mill Finish

CONNECTOR SLEEVES

Aluminum, 5" lengths

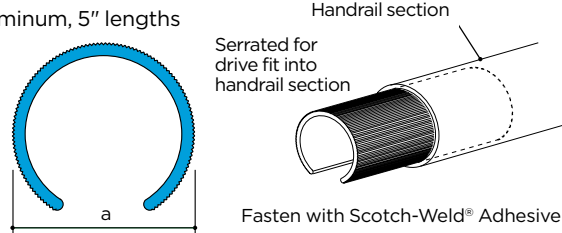

Fasten with Scotch-Weld® Adhesive

| | | a |
|--------|-------------------------------------------------------------|--------|
| ● 7063 | for 6489 Bronze and 5289 Nickel-Silver | 1.500" |
| ● 1363 | for 1.900" Nickel-Silver | 1.650" |
| ● 1160 | for 1.900" Aluminum and 1.900" Bronze | 1.682" |
| ● 1163 | for 2 1/2" Aluminum, 2 1/2" Bronze and 2 1/2" Nickel-Silver | 2.250" |
| ● 1170 | for 3" Aluminum, 3" Bronze and 3" Nickel-Silver | 2.750" |
| ● 1164 | for 3 1/2" Aluminum | 3.250" |
| ● 9363 | for 1.900" Stainless | 1.770" |
| ● 1463 | for 2 1/2" Stainless | 2.375" |
| ● 1464 | for 3" Stainless | 2.875" |
| ● 1264 | for 3 1/2" Bronze | 3.125" |
| ● 1474 | for 4" Stainless | 3.875" |

PIPE RAILINGS

TRADITIONAL RAILING COMPONENTS

This section illustrates the numerous handrail mouldings, fittings, and ornamental railing components carried in stock in aluminum, bronze, nickel-silver, steel, and stainless steel. Most can be used with the various railing systems described elsewhere in this catalog.

- **Aluminum** extrusions are of alloy 6063 which is preferred for its bright color, corrosion resistance and ease of fabrication. It is suitable for anodizing, including most of the hard coat color finishes.
- **Bronze** extrusions are of alloy C38500, architectural bronze, preferred for its rich gold color and workability.
- **Nickel-Silver** extrusions are of alloy C79800. Sometimes referred to as white bronze, nickel-silver is a copper/nickel alloy. It is similar in color to stainless steel, with golden highlights.
- **Stainless Steel** components are of type 304, 18-8, chrome nickel alloy which has high resistance to corrosion.
- **Steel** handrails are hot-rolled carbon steel, C1010.

Cast aluminum fittings are produced from Almag 35, suitable for clear anodizing. Bronze castings are of alloy C86500 for a good color match with extruded bronze. Nickel-silver fittings are cast to match extrusions. All non-ferrous fittings are satin finished; bronze and nickel-silver fittings are protected with a clear lacquer. Fittings for use with steel handrail are cast from malleable iron, which is weldable and bendable.

It is important to be aware that due to the difference in tolerances between extruded handrail and cast fittings, butt joints require special attention to ensure proper match.

All items are carried in stock in substantial quantities and are available for immediate shipment. Materials are produced and handled with great care. Items are thoroughly protected for shipment by wrapping and/or crating so as to ensure a product well-suited for architectural finishing. For structural engineering data, see pages 122-129. For handrail brackets, see pages 89-97.

The *Americans with Disabilities Act* adopted by Congress in 1992 required circular handrails to be 1 $\frac{1}{4}$ " minimum and 1 $\frac{1}{2}$ " maximum. However, the *Guidance on the 2010 ADA Standards for Accessible Design - September 2010*, published by the US Department of Justice, has clarified the intent of the dimensional requirements to be an outside diameter of 1 $\frac{1}{4}$ " to 2".

ADAAG also allows handrails which provide an equivalent gripping surface. ANSI117.1-17 defines this alternative: *equivalent gripping surfaces are permitted provided they have a perimeter dimension of 4" (100 mm) minimum and 6 $\frac{1}{4}$ " (160 mm) maximum and provided their largest cross-section dimension is 2 $\frac{1}{4}$ " (57 mm) maximum.*

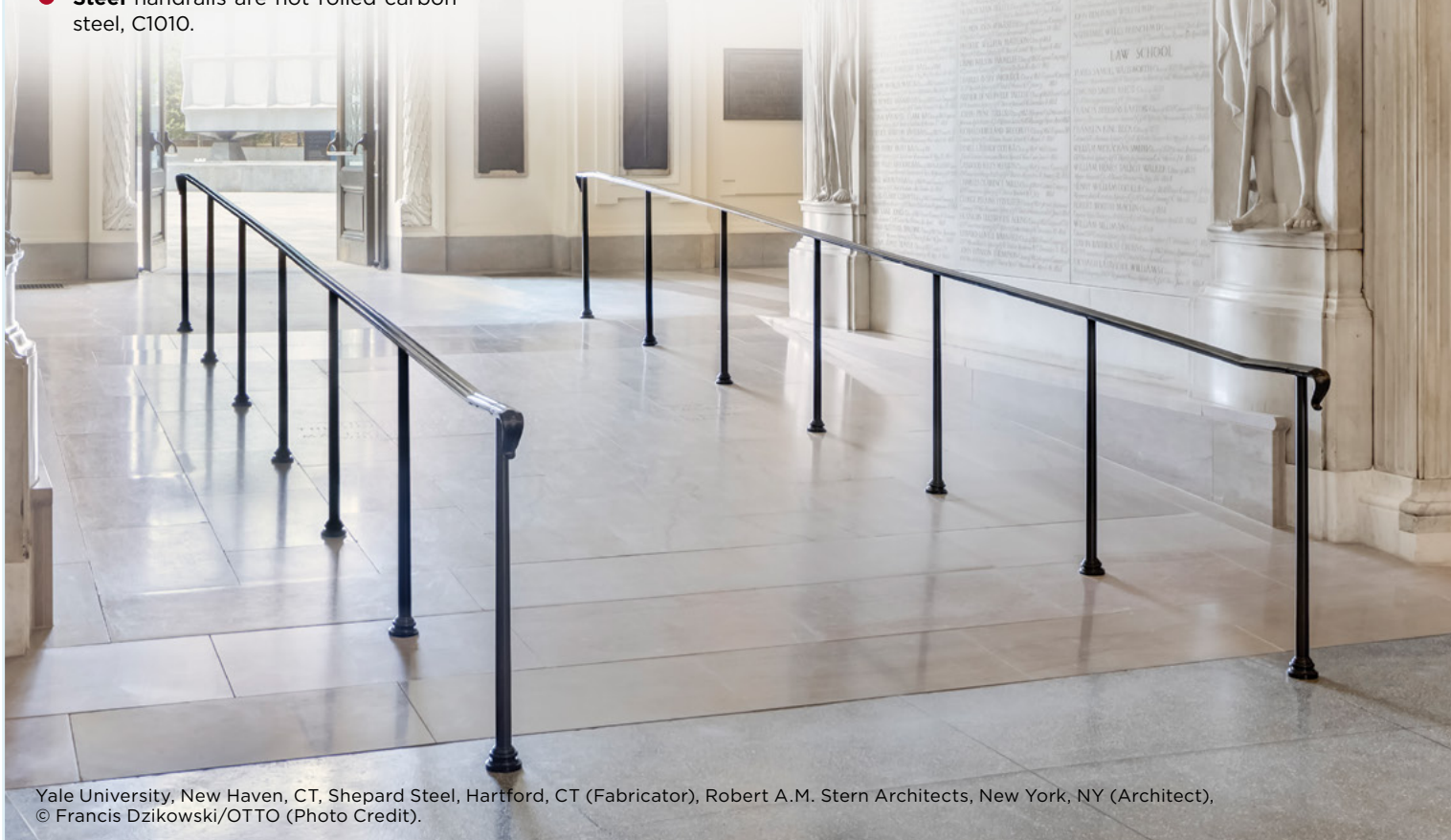

Yale University, New Haven, CT, Shepard Steel, Hartford, CT (Fabricator), Robert A.M. Stern Architects, New York, NY (Architect), © Francis Dzikowski/OTTO (Photo Credit).



Private Residence, Greenwich, CT, Artistic Ironworks LLC, Norwalk, CT (Fabricator).

● ALUMINUM Alloy 6063-T52, Mill Finish, 20' Lengths

Scale: 6" = 1'-0"

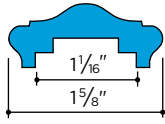

● **6931** Aluminum .615 lb/ft
Fittings: B-C-CC-CL-CR-E-GL-GR-L-N-S-T-V

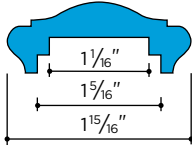

● **6934** Aluminum .804 lb/ft
Fittings: B-C-CC-CL-CR-E-GL-GR-J-L-N-S-T-V

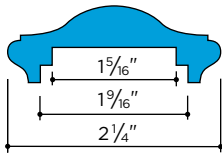

● **6930** Aluminum .936 lb/ft
Fittings: B-C-CC-CL-CR-E-GL-GR-J-L-N-S-T-V

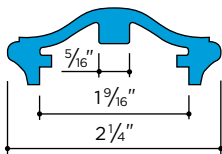

● **6929** Aluminum .670 lb/ft
Use fittings for **6930**
Outside profile identical to **6930**, for straight runs only

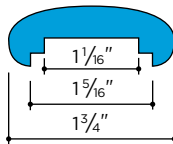

● **6933** Aluminum .770 lb/ft
Fittings: B-C-CC-CL-CR-GL-GR-N-S-V

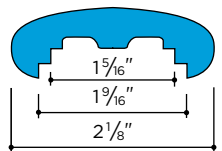

● **6935** Aluminum .980 lb/ft
Fittings: B-C-CC-CL-CR-E-GL-GR-N-S-T-V

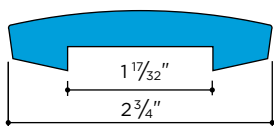

● **6984*** Aluminum 1.301 lb/ft
Fittings: C-N
*Use 1 1/2" x 1/4" flat bar for splicing and closing ends

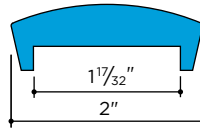

● **6985*** Aluminum .977 lb/ft
Fittings: C-N
*Use 1 1/2" x 1/4" flat bar for splicing and closing ends

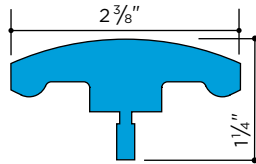

● **6402** Aluminum 1.51 lb/ft
Fittings: C-N Use fittings for **6902**

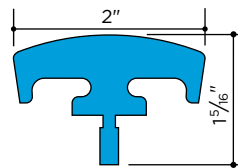

● **6405** Aluminum 1.39 lb/ft
Fittings: C-N Use fittings for **6985**

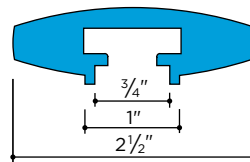

● **6532** Aluminum 1.440 lb/ft
Fittings: C-N

Mouldings **6530**, **6531**, and **6532** are used with Carlsrail® self-aligning brackets on page 82. Clamping action eliminates drilling and tapping and helps in field alignment with posts and wall attachments. See page 68 for splices, support bar and end cap. Carlsrail® mouldings are designed for non-welded assembly.

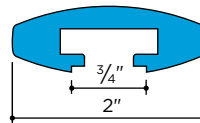

● **6530** Aluminum .900 lb/ft
Fittings: C-N

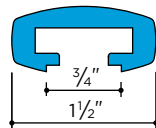

● **6531** Aluminum .600 lb/ft
Fittings: C-N

Channel corner bends and channel lateral scrolls are available in aluminum and malleable iron.

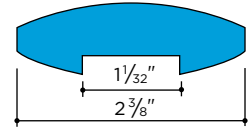

● **6902** Aluminum 1.464 lb/ft
Fittings: C-N

Mouldings **6901** and **6902** are specially designed for use with Carlstadt® aluminum self-aligning brackets **309**, **312**, **313** and **314** shown on pages 92 and 93. A 1" x 1/4" flat bar can be used for splicing and for closing the recess in the handrail moulding.

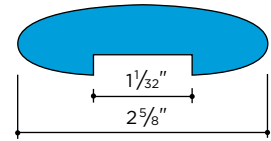

● **6901** Aluminum 1.661 lb/ft
Fittings: C-N

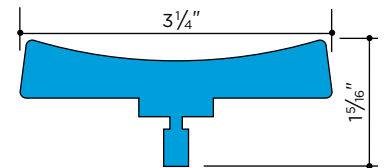

● **6407** Aluminum 2.00 lb/ft
Fittings: C-N Use fittings for **6907**

T-handrail mouldings **6402**, **6405**, and **6407** are used with Carlstadt® self-aligning brackets on pages 92 and 93. Clamping action eliminates drilling and tapping and helps in field alignment with posts and wall attachment.

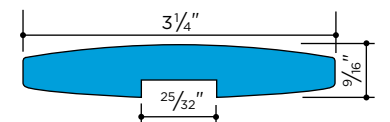

● **6905** Aluminum 1.752 lb/ft
Fittings: C-N

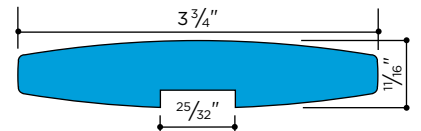

● **6906** Aluminum 2.448 lb/ft
Fittings: C-N

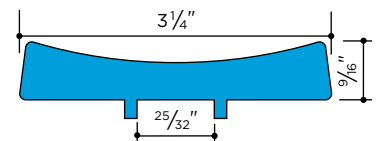

● **6907** Aluminum 1.776 lb/ft
Fittings: C-N

Mouldings **6905**, **6906**, and **6907** are specially designed for use with Carlstadt® self-aligning brackets shown on pages 90 and 91. A 3/4" x 3/16" flat bar may be used for closing the recess in the handrail moulding.

● ALUMINUM Alloy 6063-T52, Mill Finish, 20' Lengths

Scale: 6" = 1'-0"

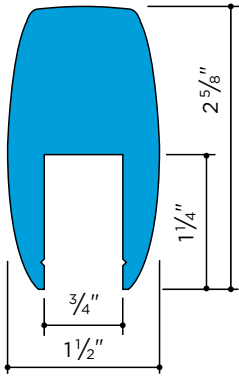

● 1133* Aluminum 3.02 lb/ft

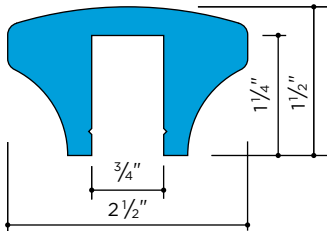

● 1134* Aluminum 2.40 lb/ft

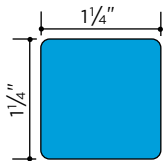

● 6423* Aluminum 1.876 lb/ft

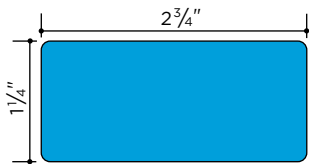

● 6424* Aluminum 4.124 lb/ft

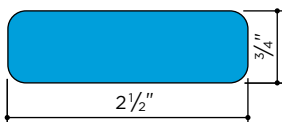

● 6939* Aluminum 2.214 lb/ft

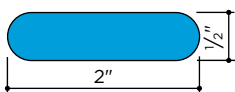

● 6988* Aluminum 1.138 lb/ft

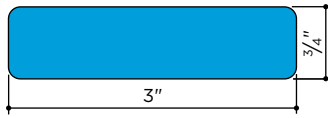

● 6986* Aluminum 2.684 lb/ft

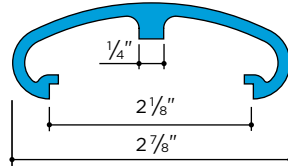

● 6932 Aluminum .852 lb/ft

Fittings: B-C-N-S

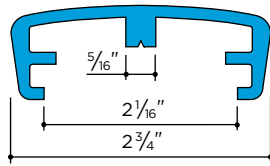

● 6987 Aluminum .858 lb/ft

Fittings: C-N

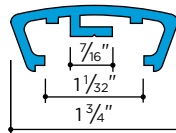

● 6903* Aluminum .446 lb/ft

Use with 1" x 1/2" x 1/8" channel

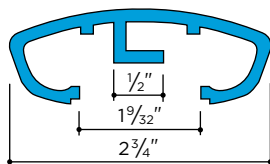

● 6904* Aluminum .858 lb/ft

Use with 1 1/4" x 3/4" x 1/8" channel

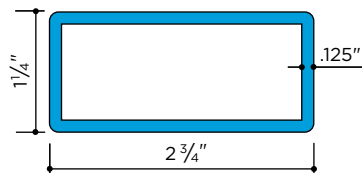

● 6434 Aluminum 6063-T6 1.123 lb/ft

Fittings: N (see page 81)

* No fittings available.

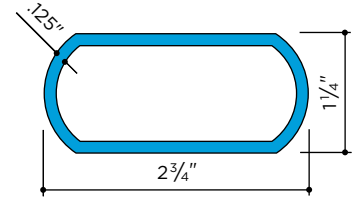

● 6435 Aluminum 6063-T6 1.075 lb/ft

Fittings: C-N (see pages 38 and 81)

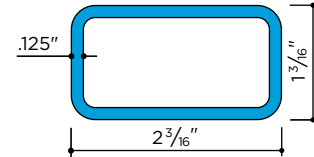

● 6436 Aluminum .888 lb/ft

Fittings: N

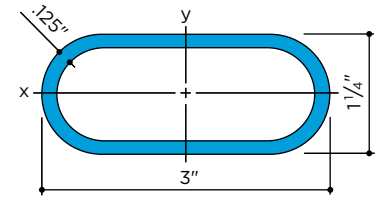

● 6437 Aluminum 1.057 lb/ft

Fittings: N

Aluminum Handrail Fittings

Symbols and Letter Designations

When specifying a fitting, add fitting designation to handrail molding number (e.g. 6930-V). See pages 111 and 114 for available channel sizes.

ALUMINUM

| | | |
|----|--|------------------------------|
| B | | Bevel Lamb's Tongue |
| C | | Corner Bend |
| CC | | Channel Corner Bend |
| CL | | Left Channel Lateral Scroll |
| CR | | Right Channel Lateral Scroll |
| E | | Terminal |
| GL | | Left Lateral Scroll |
| GR | | Right Lateral Scroll |
| J | | Round Terminal |
| L | | Corner Piece |
| N | | Square End Piece |
| S | | Straight Lamb's Tongue |
| T | | Center Piece |
| V | | Volute |

MALLEABLE IRON

| | | |
|----|--|------------------------------|
| CC | | Channel Corner Bend |
| CL | | Left Channel Lateral Scroll |
| CR | | Right Channel Lateral Scroll |

● BRONZE Alloy C38500, Mill Finish, 20' lengths, except as noted

Scale: 6" = 1'-0"

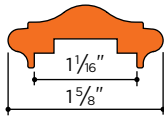

● **4531** Bronze 1.93 lb/ft
Fittings: B-C-E-GL-GR-J-L-N-S-U-V

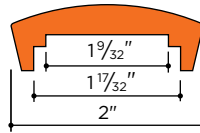

● **4575** Bronze 2.37 lb/ft
Fittings: C-N

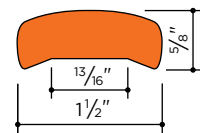

● **4503** Bronze 2.73 lb/ft
No fittings available

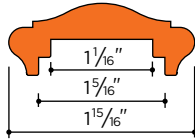

● **4534** Bronze 2.80 lb/ft
Fittings: B-C-E-GL-GR-J-L-N-S-T-V

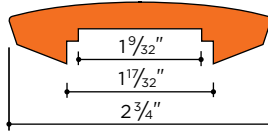

● **4574** Bronze 3.71 lb/ft
Fittings: C-N

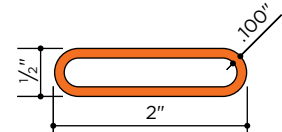

● **6488** Bronze 1.56 lb/ft
Fittings: N
16' lengths

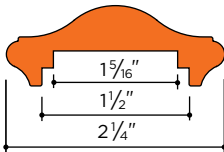

● **4530** Bronze 3.10 lb/ft
Fittings: B-C-E-GL-GR-J-L-N-S-T-V

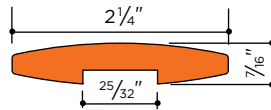

● **4572** Bronze 2.50 lb/ft
Fittings: C-N

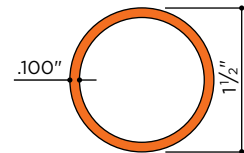

● **6489** Bronze 1.75 lb/ft
Fittings: C-D-N

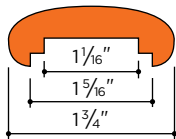

● **4539** Bronze 2.66 lb/ft
Fittings: B-C-CC-CL-CR-GL-GR-N-S-V

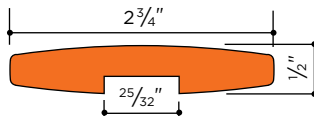

● **4573** Bronze 4.05 lb/ft
Fittings: C-N

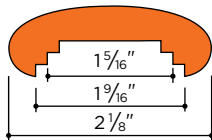

● **4535** Bronze 3.35 lb/ft
Fittings: B-C-CC-CL-CR-GL-GR-N-S-T-V

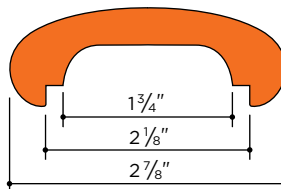

● **4529** Bronze 4.87 lb/ft
Fittings: N

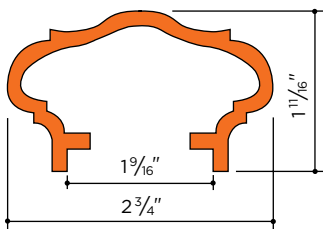

● **4538** Bronze 3.15 lb/ft
Fittings: N
16' lengths

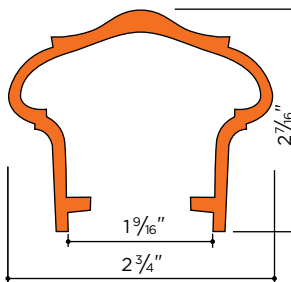

● **4533** Bronze 3.66 lb/ft
No fittings available
16' lengths

Channel corner bends and channel lateral scrolls are available in bronze and malleable iron.

Bronze Handrail Fittings

Symbols and Letter Designations

When specifying a fitting, add fitting designation to handrail moulding number (e.g. **4530-V**). See pages 114-115 for available channel sizes.

| BRONZE | | |
|----------------|--|------------------------------|
| B | | Bevel Lamb's Tongue |
| C | | Corner Bend |
| CC | | Channel Corner Bend |
| CL | | Left Channel Lateral Scroll |
| CR | | Right Channel Lateral Scroll |
| D | | Domed End Cap |
| E | | Terminal |
| GL | | Left Lateral Scroll |
| GR | | Right Lateral Scroll |
| J | | Round Terminal |
| L | | Corner Piece |
| N | | Square End Piece |
| S | | Straight Lamb's Tongue |
| T | | Center Piece |
| U | | End Urn Base |
| V | | Volute |
| MALLEABLE IRON | | |
| CC | | Channel Corner Bend |
| CL | | Left Channel Lateral Scroll |
| CR | | Right Channel Lateral Scroll |

● NICKEL-SILVER Alloy C79800, Mill Finish, 20' lengths, except as noted

Scale: 6" = 1'-0"

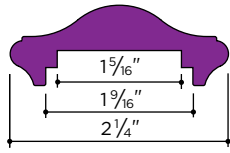

● **5530** Nickel-Silver 2.91 lb/ft
Fittings: B-C-GL-GR-N-S-V
16' lengths

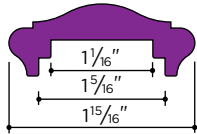

● **5534** Nickel-Silver 2.52 lb/ft
Fittings: B-C-GL-GR-N-S-V

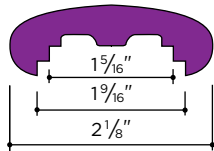

● **5235** Nickel-Silver 3.16 lb/ft
Fittings: B-C-GL-GR-N-S-V

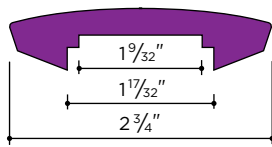

● **5274** Nickel-Silver 3.71 lb/ft
Fittings: C-N

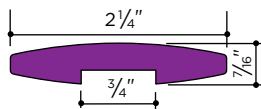

● **5572** Nickel-Silver 2.50 lb/ft
Fittings: C-N

Channel corner bends and channel lateral scrolls are available in nickel-silver and malleable iron.

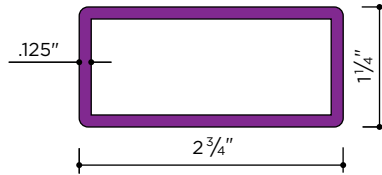

● **1334** Nickel-Silver 3.40 lb/ft
Fittings: N (See page 81)
16' lengths

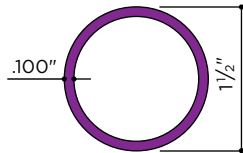

● **5289** Nickel-Silver 1.75 lb/ft
Fittings: N

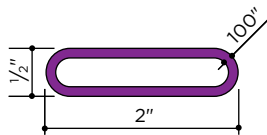

● **5288** Nickel-Silver 1.56 lb/ft
Fittings: N

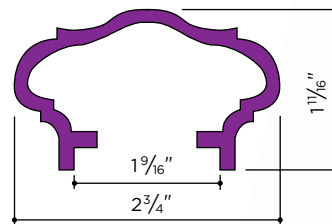

● **5538** Nickel-Silver 2.96 lb/ft
Fittings: N

Nickel-Silver Handrail Fittings

Symbols and Letter Designations

When specifying a fitting, add fitting designation to handrail moulding number (e.g. **5534-V**). See pages 114 and 118 for available channel sizes.

NICKEL-SILVER

| | | |
|-----------|--|------------------------------|
| B | | Bevel Lamb's Tongue |
| C | | Corner Bend |
| CC | | Channel Corner Bend |
| CL | | Left Channel Lateral Scroll |
| CR | | Right Channel Lateral Scroll |
| E | | Terminal |
| GL | | Left Lateral Scroll |
| GR | | Right Lateral Scroll |
| L | | Corner Piece |
| N | | Square End Piece |
| S | | Straight Lamb's Tongue |
| V | | Volute |

MALLEABLE IRON

| | | |
|-----------|--|------------------------------|
| CC | | Channel Corner Bend |
| CL | | Left Channel Lateral Scroll |
| CR | | Right Channel Lateral Scroll |

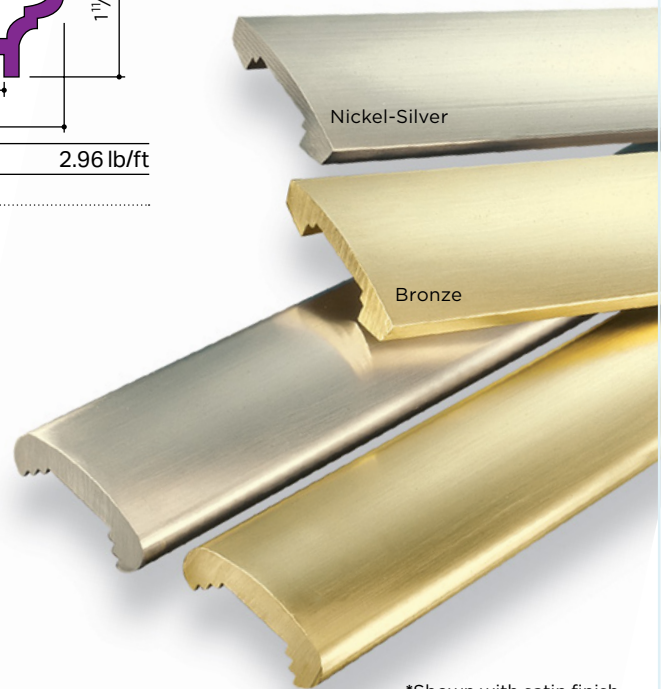

*Shown with satin finish.

● STAINLESS Type 304 (18-8), 20' lengths, except as noted ● STEEL C1010, 20' lengths

Scale: 6" = 1'-0", except as noted

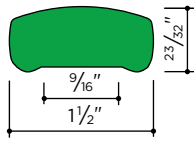

● **6503** Stainless 2.54 lb/ft
No fittings available
16' lengths

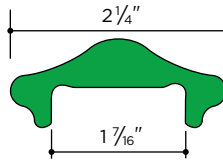

● **6513** Stainless 2.85 lb/ft
Fittings: N

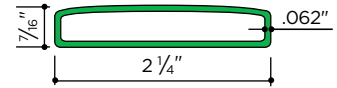

● **6512** Stainless 1.00 lb/ft
Fittings: N

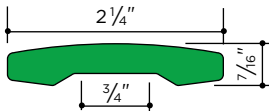

● **6502** Stainless 2.80 lb/ft
No fittings available
16' lengths

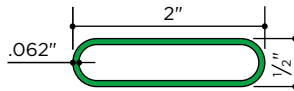

● **4488** Stainless .944 lb/ft
Fittings: N Suitable for elevator cab handrails

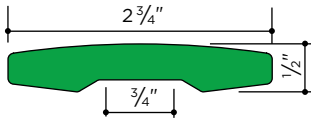

● **6501** Stainless 4.05 lb/ft
No fittings available
16' lengths

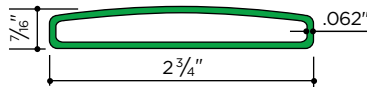

● **6511** Stainless 1.25 lb/ft
Fittings: N

Steel mouldings are hot-rolled carbon steel, C1010. Fittings are cast in malleable iron, making them weldable and bendable.

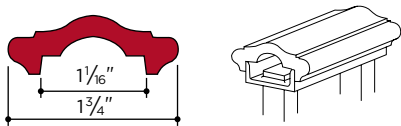

4429 used with 1" channel

● **4429** Prime Domestic Steel 1.50 lb/ft
Fittings: B-C-CC-CL-CR-E-F-GL-GR-JL-JR-L-N-S-SL-SR-T-U-UC-UL-V

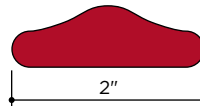

● **4416** Steel 3.15 lb/ft
No fittings available

Loafer Rail



● **4445** Steel .688 lb/ft
Loafer rail fits over pipe or flat surface to discourage lounging or skating on fences, planters, railings, or storefronts.

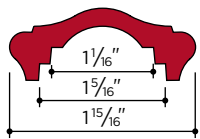

● **4428** Steel 2.25 lb/ft
Fittings: B-C-CC-CL-CR-E-GL-GR-L-N-S-V

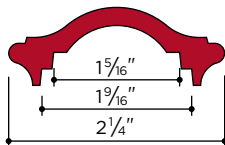

● **4441** Steel 2.14 lb/ft
Fittings: B-C-CC-CL-CR-E-GL-GR-N-S-T-U-UC-V

Wall Flange

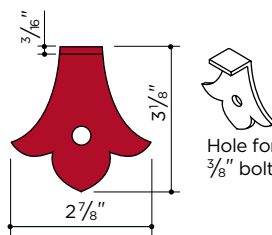

● **401*** Steel * Scale: 3" = 1'-0"

Stainless Steel Handrail Fittings
Symbols and Letter Designations

When specifying a fitting, add fitting designation to handrail moulding number (e.g. **4488-N**). See page 120 for available channel sizes.

| STAINLESS | |
|-----------|------------------|
| C | Corner Bend |
| N | Square End Piece |

Steel Handrail Fittings
Symbols and Letter Designations

When specifying a fitting, add fitting designation to handrail moulding number (e.g. **4441-V**). See page 114 for available channel sizes.

| MALLEABLE IRON | |
|----------------|------------------------------|
| B | Bevel Lamb's Tongue |
| C | Corner Bend |
| CC | Channel Corner Bend |
| CL | Left Channel Lateral Scroll |
| CR | Right Channel Lateral Scroll |
| E | Terminal |
| F | Forged Lamb's Tongue |
| GL | Left Lateral Scroll |
| GR | Right Lateral Scroll |
| JL | Left Junior Lateral Scroll |
| JR | Right Junior Lateral Scroll |
| L | Corner Piece |
| N | Square End Piece |
| S | Straight Lamb's Tongue |
| SL | Left Junior Lateral Channel |
| SR | Right Junior Lateral Channel |
| T | Center Piece |
| U | End Urn Base |
| UC | Center Urn Base |
| UL | Corner Urn Base |
| V | Volute |

● ALUMINUM ● BRONZE ● NICKEL-SILVER ● STAINLESS ● MALLEABLE IRON / STEEL

HANDRAIL FITTINGS

Satin finish, except as noted. Bronze and nickel-silver fittings are lacquered. See pages 40-42 for specific fittings availability.

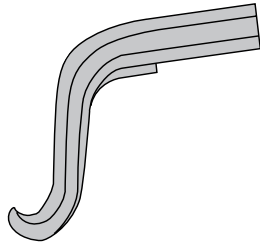

B ζ Bevel Lamb's Tongue

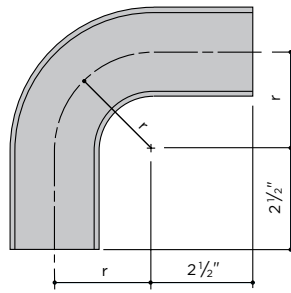

C ⤴ Corner Bend
Trim one leg for use as a wall return.
Combine two corner bends together for 180° turns.

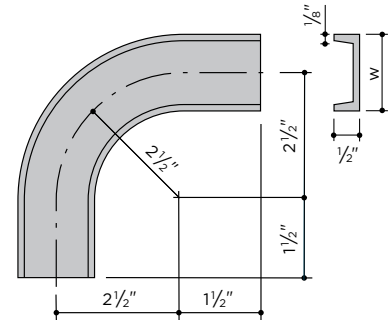

CC ⤴ Channel Corner Bend
"As Cast" finish
Fits the underside of moulding corner bend.

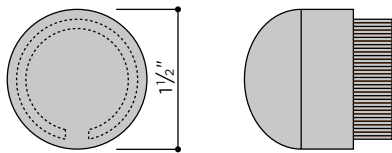

D ◐ Domed End Cap

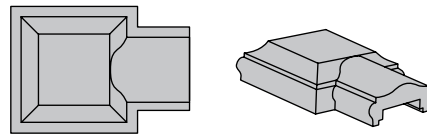

E ◑ Terminal

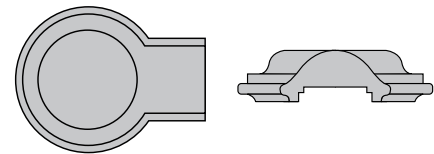

J ◐ Round Terminal

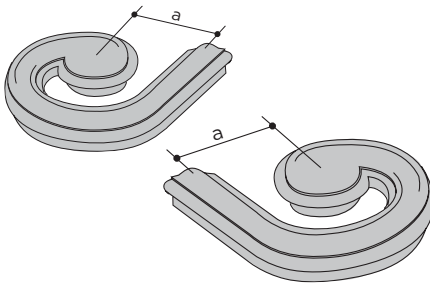

MOULDING LATERAL SCROLLS

Satin finish, except as noted. Moulding lateral scrolls may be bent to meet the pitch of stair railings. Cast channel and steel flat bar scrolls fit the underside of moulding lateral scrolls. They may be punched for round or square balusters. Malleable iron produced in "As Cast" finish.

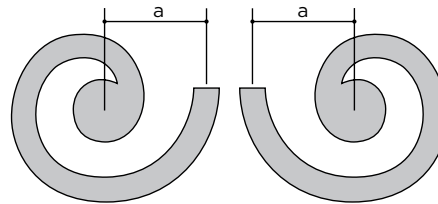

GL ◑ Left Lateral Scroll
GR ◑ Right Lateral Scroll

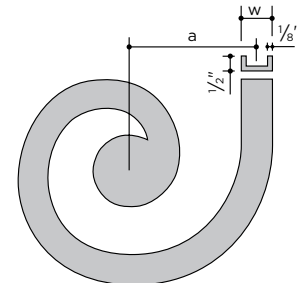

CL ◑ Left Channel Lateral Scroll
CR ◑ Right Channel Lateral Scroll
Fits the underside of moulding lateral scroll.

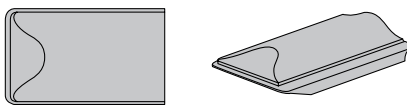

N** ◑ Square End Piece

** Stainless and steel with square front corners

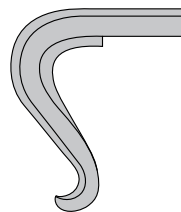

S ζ Straight Lamb's Tongue

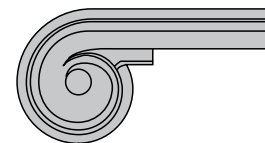

V ◑ Volute

TRADITIONAL RAILING COMPONENTS

Be aware that due to the differences in tolerances between extruded handrail and cast fittings, butt joints usually require special attention to ensure a proper match.

● ALUMINUM ● BRONZE ● MALLEABLE IRON

FINIAL BASES, CENTER PIECES, CORNER PIECES, TERMINALS AND URN BASES

Satin finish, except as noted. Bronze and nickel-silver fittings are lacquered. See page 53 for Urn and Ball Finials. Urn bases may be welded or bolted in place with the finial stud.

Be aware that due to the difference in tolerances between extruded handrail and cast fittings, butt joints usually require special attention to ensure a proper match.

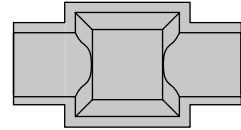
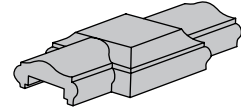
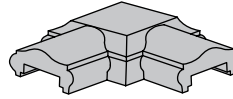
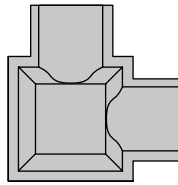
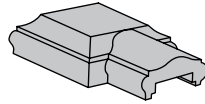
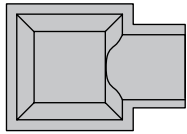

E Terminal

L Corner Piece

T Center Piece

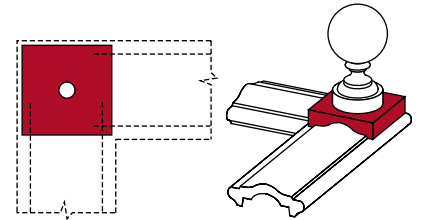
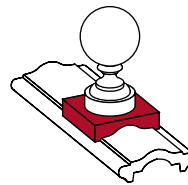
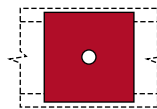
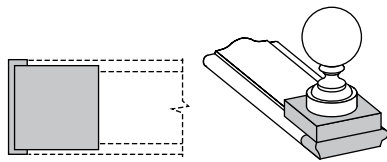

U End Urn Base

UC Center Urn Base

UL Corner Urn Base

TERMINALS, CENTER PIECES & CORNER PIECE FITTING AVAILABILITY

| Handrail Moulding | Terminal End Piece (E) | Corner Piece (L) | Center Piece (T) | End Urn Base (U) | Handrail Moulding | Terminal End Piece (E) | Corner Piece (L) | Center Piece (T) | End Urn Base (U) |
|-------------------|------------------------|------------------|------------------|------------------|-------------------|------------------------|------------------|------------------|------------------|
| ● 6929 | ● 6930E | ● 6930L | ● 6930T | - | ● 4531 | ● 4531E | ● 4531L | - | ● 4531U |
| ● 6930 | ● 6930E | ● 6930L | ● 6930T | - | ● 4534 | ● 4534E | ● 4534L | ● 4534T | - |
| ● 6931 | ● 6931E | ● 6931L | ● 6931T | - | ● 4535 | - | - | ● 4535T | - |
| ● 6934 | ● 6934E | ● 6934L | ● 6934T | - | ● 4428 | ● 4428E | ● 4428L | - | - |
| ● 6935 | ● 6935E | - | ● 6935T | - | ● 4429 | ● 4429E | ● 4429L | ● 4429T | ● 4429U |
| ● 4530 | ● 4530E | ● 4530L | ● 4530T | - | ● 4441 | ● 4441E | - | - | ● 4441U |

HANDRAIL FITTINGS FOR USE WITH 4429

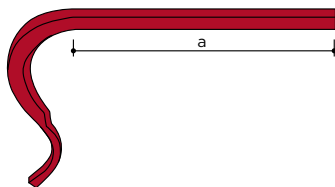

F Forged Lamb's Tongue

| | a |
|-----------------|-----|
| ● 4429F Steel | 18" |
| ● 4429F-3 Steel | 36" |
| ● 4429F-4 Steel | 48" |
| ● 4429F-5 Steel | 60" |
| ● 4429F-6 Steel | 72" |

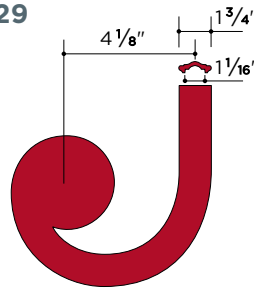

Lateral Scroll

| SL Left Junior Lateral Scroll | |
|---------------------------------------|--|
| SR Right Junior Lateral Scroll | |
| ● 4429SL Malleable Iron | |
| ● 4429SR Malleable Iron | |

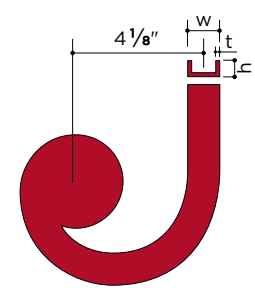

Lateral Channel

| | w | h | t |
|----------------------------------------|----|------|------|
| JL Left Junior Lateral Channel | | | |
| JR Right Junior Lateral Channel | | | |
| ● 100JL Malleable Iron | 1" | 1/2" | 1/8" |
| ● 100JR Malleable Iron | 1" | 1/2" | 1/8" |

● ALUMINUM ● BRONZE ● NICKEL-SILVER ● MALLEABLE IRON

CORNER BEND RADIUS

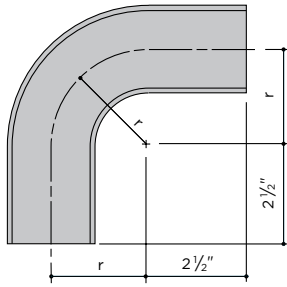

| Corner Bend (C) | Bend Radius(r) |
|------------------|----------------|
| ● 6435C Aluminum | 3" |
| ● 6530C Aluminum | 4" |
| ● 6531C Aluminum | 4" |
| ● 6532C Aluminum | 4" |
| ● 6901C Aluminum | 2 1/2" |
| ● 6902C Aluminum | 2 1/2" |

| Corner Bend (C) | Bend Radius(r) |
|------------------|----------------|
| ● 6905C Aluminum | 3" |
| ● 6906C Aluminum | 3" |
| ● 6907C Aluminum | 3" |
| ● 6930C Aluminum | 2 1/2" |
| ● 6931C Aluminum | 2 1/2" |
| ● 6932C Aluminum | 3" |
| ● 6933C Aluminum | 2 1/2" |
| ● 6934C Aluminum | 2 1/2" |
| ● 6935C Aluminum | 2 1/2" |
| ● 6984C Aluminum | 3" |
| ● 6985C Aluminum | 2 1/2" |
| ● 6987C Aluminum | 3" |
| ● 4530C Bronze | 2 1/2" |
| ● 4531C Bronze | 2 1/2" |
| ● 4534C Bronze | 2 1/2" |

| Corner Bend (C) | Bend Radius(r) |
|-------------------------|----------------|
| ● 4535C Bronze | 2 1/2" |
| ● 4539C Bronze | 2 1/2" |
| ● 4572C Bronze | 2 1/2" |
| ● 4573C Bronze | 3" |
| ● 4574C Bronze | 3" |
| ● 4575C Bronze | 2 1/2" |
| ● 6489C Bronze | 5" |
| ● 5235C Nickel-Silver | 2 1/2" |
| ● 5274C Nickel-Silver | 3" |
| ● 5530C Nickel-Silver | 2 1/2" |
| ● 5534C Nickel-Silver | 2 1/2" |
| ● 5572C Nickel-Silver | 2 1/2" |
| ● 4428C* Malleable Iron | 2 1/2" |
| ● 4429C* Malleable Iron | 2 1/2" |
| ● 4441C* Malleable Iron | 2 1/2" |

* "As cast" finish, no lacquer

CHANNEL CORNER BEND DIMENSIONS

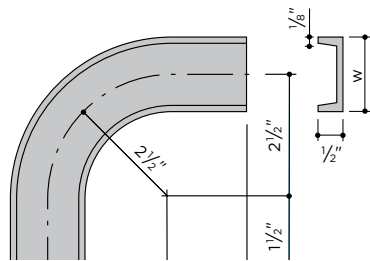

| Channel Corner Bend (CC) | w |
|--------------------------|--------|
| ● 600CC Aluminum | 1" |
| ● 615CC Aluminum | 1 1/4" |
| ● 650CC Aluminum | 1 1/2" |
| ● 400CC Bronze | 1" |
| ● 425CC Bronze | 1 1/4" |
| ● 450CC Bronze | 1 1/2" |
| ● 1315CC Nickel-Silver | 1 1/4" |
| ● 1350CC Nickel-Silver | 1 1/2" |
| ● 100CC Malleable Iron | 1" |
| ● 125CC Malleable Iron | 1 1/4" |
| ● 150CC Malleable Iron | 1 1/2" |

CHANNEL LATERAL SCROLL DIMENSIONS

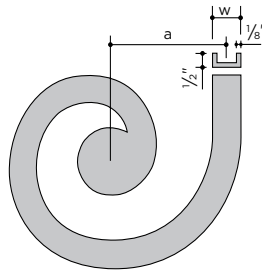

| Channel Lateral Scroll (CL/CR) | Lateral "a" | w |
|--------------------------------|-------------|--------|
| ● 600CL/CR Aluminum | 5 9/16" | 1" |
| ● 615CL/CR Aluminum | 5 1/2" | 1 1/4" |
| ● 650CL/CR Aluminum | 6 3/8" | 1 1/2" |
| ● 400CL/CR Bronze | 5 9/16" | 1" |
| ● 425CL/CR Bronze | 5 1/2" | 1 1/4" |
| ● 450CL/CR Bronze | 6 3/8" | 1 1/2" |
| ● 1315CL/CR Nickel-Silver | 5 1/2" | 1 1/4" |
| ● 1350CL/CR Nickel-Silver | 6 3/8" | 1 1/2" |
| ● 100CL/CR Malleable Iron | 5 9/16" | 1" |
| ● 125CL/CR Malleable Iron | 5 1/2" | 1 1/4" |
| ● 150CL/CR Malleable Iron | 6 3/8" | 1 1/2" |

LATERAL SCROLL DIMENSION

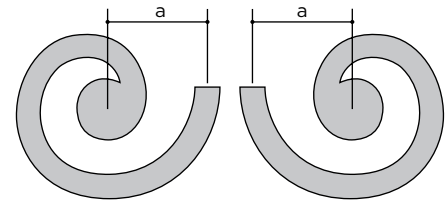

| Lateral Scroll (GL/GR) | Lateral "a" Dimension |
|----------------------------|-----------------------|
| ● 6930GL/GR Aluminum | 6 3/8" |
| ● 6931GL/GR Aluminum | 5 9/16" |
| ● 6933GL/GR Aluminum | 5 1/2" |
| ● 6934GL/GR Aluminum | 5 1/2" |
| ● 6935GL/GR Aluminum | 6 3/8" |
| ● 4530GL/GR Bronze | 6 3/8" |
| ● 4531GL/GR Bronze | 5 9/16" |
| ● 4534GL/GR Bronze | 5 1/2" |
| ● 4535GL/GR Bronze | 6 3/8" |
| ● 4539GL/GR Bronze | 5 1/2" |
| ● 5235GL/GR Nickel-Silver | 6 3/8" |
| ● 5530GL/GR Nickel-Silver | 6 3/8" |
| ● 5534GL/GR Nickel-Silver | 5 1/2" |
| ● 4428GL/GR Malleable Iron | 5 1/2" |
| ● 4429GL/GR Malleable Iron | 5 5/8" |
| ● 4441GL/GR Malleable Iron | 6 1/8" |

* Verify all dimensions before cutting.

TRADITIONAL RAILING COMPONENTS

HANDRAIL FITTINGS AVAILABILITY

● ALUMINUM ● BRONZE ● NICKEL-SILVER ● STAINLESS ● MALLEABLE IRON

| Handrail Moulding | Corner Bend (C) | Non-Ferrous Corner Bend * | Iron Corner Bend * |
|----------------------|-------------------------|---------------------------|------------------------|
| ● 6402 Aluminum | ● 6902C Aluminum | - | - |
| ● 6405 Aluminum | ● 6985C Aluminum | - | - |
| ● 6407 Aluminum | ● 6907C Aluminum | - | - |
| ● 6434 Aluminum | ● 6434C Aluminum | - | - |
| ● 6435 Aluminum | ● 6435C Aluminum | - | - |
| ● 6436 Aluminum | - | - | - |
| ● 6437 Aluminum | - | - | - |
| ● 6530 Aluminum | ● 6530C Aluminum | - | - |
| ● 6531 Aluminum | ● 6531C Aluminum | - | - |
| ● 6532 Aluminum | ● 6532C Aluminum | - | - |
| ● 6901 Aluminum | ● 6901C Aluminum | ● 600CC Aluminum | ● 100CC Malleable Iron |
| ● 6902 Aluminum | ● 6902C Aluminum | ● 600CC Aluminum | ● 100CC Malleable Iron |
| ● 6905 Aluminum | ● 6905C Aluminum | - | - |
| ● 6906 Aluminum | ● 6906C Aluminum | - | - |
| ● 6907 Aluminum | ● 6907C Aluminum | - | - |
| ● 6929 Aluminum | ● 6930C Aluminum | ● 650CC Aluminum | ● 150CC Malleable Iron |
| ● 6930 Aluminum | ● 6930C Aluminum | ● 650CC Aluminum | ● 150CC Malleable Iron |
| ● 6931 Aluminum | ● 6931C Aluminum | ● 600CC Aluminum | ● 100CC Malleable Iron |
| ● 6932 Aluminum | ● 6932C Aluminum | - | - |
| ● 6933 Aluminum | ● 6933C Aluminum | ● 615CC Aluminum | ● 125CC Malleable Iron |
| ● 6934 Aluminum | ● 6934C Aluminum | ● 615CC Aluminum | ● 125CC Malleable Iron |
| ● 6935 Aluminum | ● 6935C Aluminum | ● 650CC Aluminum | ● 150CC Malleable Iron |
| ● 6984 Aluminum | ● 6984C Aluminum | - | - |
| ● 6985 Aluminum | ● 6985C Aluminum | ● 650CC Aluminum | ● 150CC Malleable Iron |
| ● 6987 Aluminum | ● 6987C Aluminum | - | - |
| ● 4529 Bronze | - | - | - |
| ● 4530 Bronze | ● 4530C Bronze | ● 450CC Bronze | ● 150CC Malleable Iron |
| ● 4531 Bronze | ● 4531C Bronze | ● 400CC Bronze | ● 100CC Malleable Iron |
| ● 4534 Bronze | ● 4534C Bronze | ● 425CC Bronze | ● 125CC Malleable Iron |
| ● 4535 Bronze | ● 4535C Bronze | ● 450CC Bronze | ● 150CC Malleable Iron |
| ● 4538 Bronze | - | - | - |
| ● 4539 Bronze | ● 4539C Bronze | ● 425CC Bronze | ● 125CC Malleable Iron |
| ● 4572 Bronze | ● 4572C Bronze | - | - |
| ● 4573 Bronze | ● 4573C Bronze | - | - |
| ● 4574 Bronze | ● 4574C Bronze | - | - |
| ● 4575 Bronze | ● 4575C Bronze | ● 450CC Bronze | ● 150CC Malleable Iron |
| ● 6488 Bronze | - | - | - |
| ● 6489 Bronze | ● 6489C Bronze | - | - |
| ● 5235 Nickel-Silver | ● 5235C Nickel-Silver | ● 1350CC Nickel-Silver | ● 150CC Malleable Iron |
| ● 5274 Nickel-Silver | ● 5274C Nickel-Silver | - | - |
| ● 5288 Nickel-Silver | - | - | - |
| ● 5289 Nickel-Silver | - | - | - |
| ● 5530 Nickel-Silver | ● 5530C Nickel-Silver | ● 1350CC Nickel-Silver | ● 150CC Malleable Iron |
| ● 5534 Nickel-Silver | ● 5534C Nickel-Silver | ● 1315CC Nickel-Silver | ● 125CC Malleable Iron |
| ● 5538 Nickel-Silver | - | - | - |
| ● 5572 Nickel-Silver | ● 5572C Nickel-Silver | - | - |
| ● 4428 Steel | ● 4428C* Malleable Iron | - | ● 125CC Malleable Iron |
| ● 4429 Steel | ● 4429C* Malleable Iron | - | ● 100CC Malleable Iron |
| ● 4441 Steel | ● 4441C* Malleable Iron | - | ● 150CC Malleable Iron |
| ● 4488 Stainless | - | - | - |
| ● 6511 Stainless | - | - | - |
| ● 6512 Stainless | - | - | - |

* "As cast" finish, no lacquer

Be aware that due to the differences in tolerances between extruded handrail and cast fittings, butt joints usually require special attention to ensure a proper match.



POSTS
SPINDLES
COLLARS
BASES

Private Residence, Newport, RI, Cordtsen Design Architecture, Middletown, RI, Tampa, FL (Architect/Designer), Salmon Studios, Florence, MA (Designer/Fabricator), Parker Construction, East Providence, RI (General Contractor).

STARTING POSTS

● ALUMINUM ● BRONZE ● NICKEL-SILVER ● MALLEABLE IRON/STEEL ● STAINLESS

Starting Posts from Julius Blum & Co., Inc. have been engineered and tested to conform to the ASTM E985 concentrated test load requirement. Copies of the Test Reports are available. Scale: 1" = 1'-0" Available bases, flanges and collars on pages 50-52.

40"

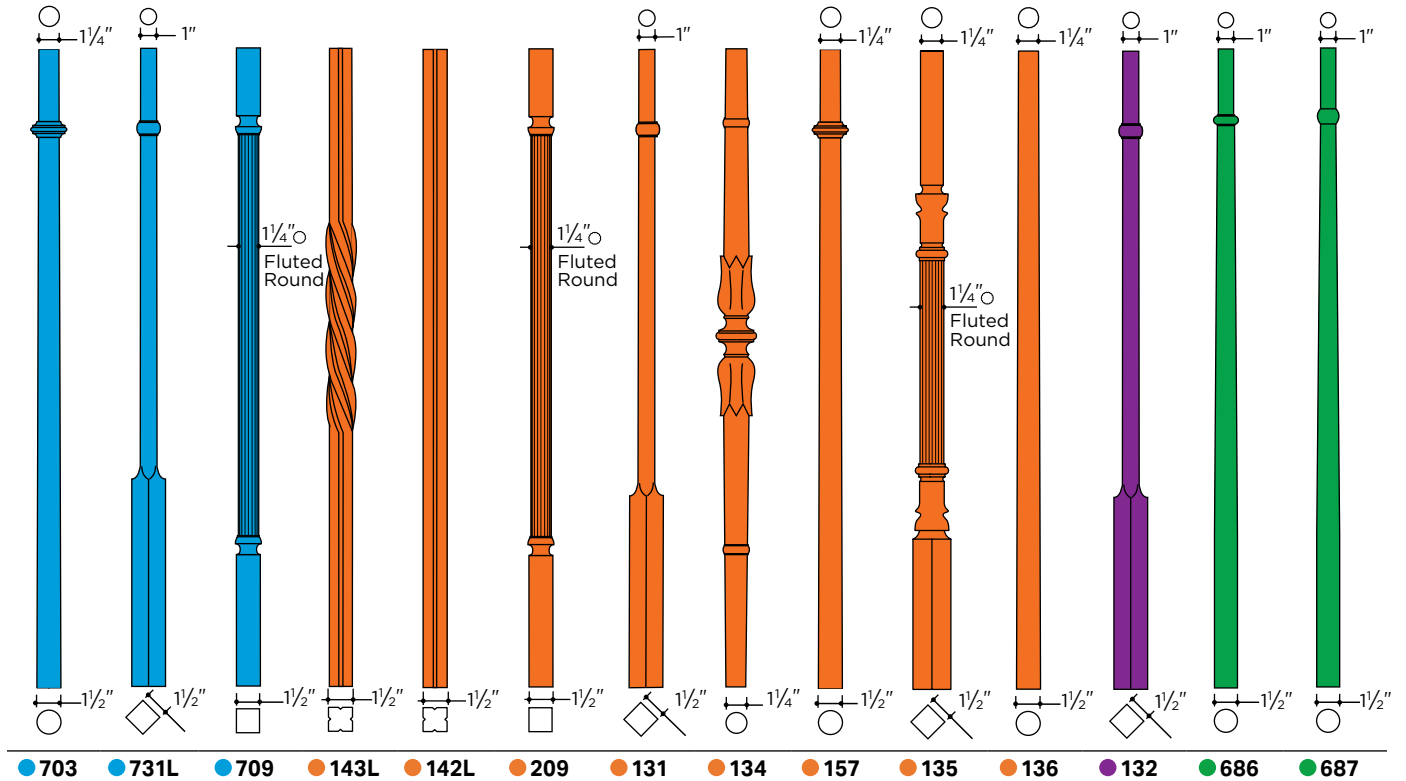

● 703 ● 731L ● 709 ● 143L ● 142L ● 209 ● 131 ● 134 ● 157 ● 135 ● 136 ● 132 ● 686 ● 687
 Aluminum Aluminum Aluminum Forged Bronze Bronze Bronze Bronze Bronze Bronze Bronze Nickel-Silver Stainless Stainless

40"

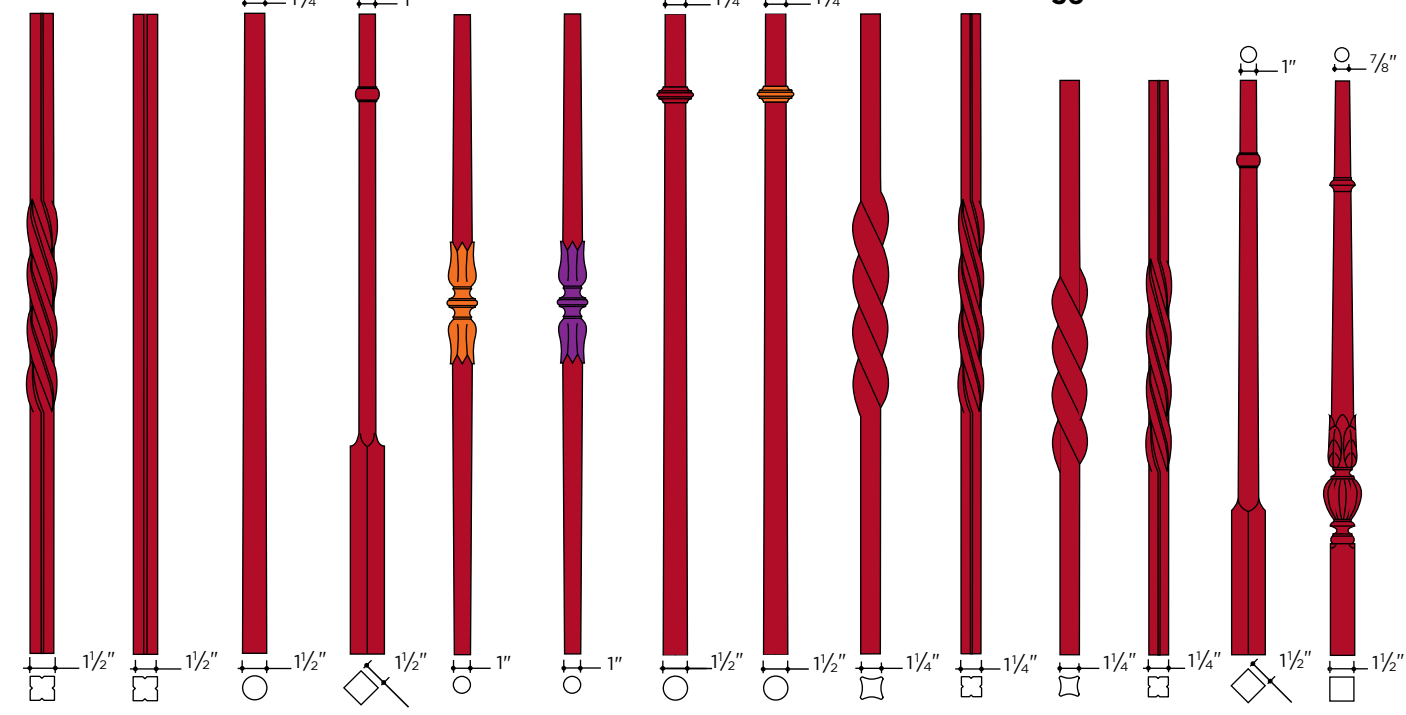

● 347L ● 345L ● 326L ● 331L ● 340 ● 341 ● 155 ● 156 ● 332L ● 343L ● 332 ● 343 ● 331 ● 333
 Forged Forged Forged Forged Steel w/ Steel w/ Forged Forged Forged Forged Forged Forged Forged Forged Forged Malleable
 Steel Steel Steel Steel w/ Nickel-Silver Steel Steel Steel Steel Steel Steel Steel Steel Steel Steel Iron
 Center Center

● BRONZE ● NICKEL-SILVER ● STEEL



Municipal Building, AGAR Welding, Walnut Bottom, PA (Fabricator), Lobar, Inc., Dillsburg, PA (General Contractor).

TRADITIONAL RAILING COMPONENTS

Bronze and Nickel-Silver Center Detail

Forged steel spindles with decorative centers are forged in two halves with one end turned down to 1/2" diameter solid rod. This rod is force-fit into a recess drilled in the other half of the spindle forming a permanent assembly with a full 1/2" of solid steel at the center, thereby overcoming the weakness of an assembly using a threaded stud.

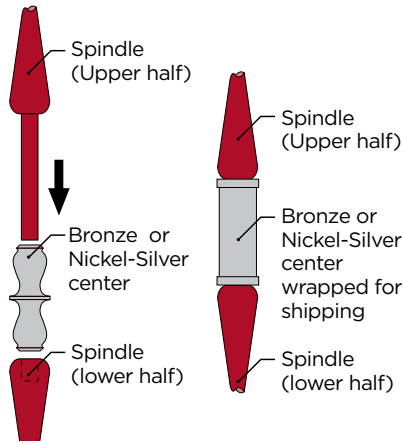

TRADITIONAL POST LOWER COVER



● 887 Bronze

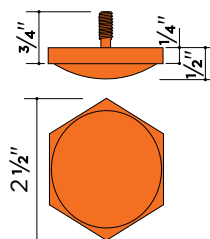

Spindle Cups are machined from solid stock. Bronze and nickel-silver cups are furnished in a satin finish and laquered. Steel cups are furnished in a black oxide machined finish suitable for painting. Spindle cups are not intended or designed to be a structural member.

RINGED SPINDLE CUP

Rounded Hole

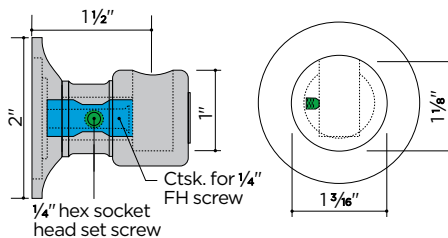

| | | Hole |
|--------|---------------|------|
| ● 884 | Bronze | 1/2" |
| ● 184 | Nickel-Silver | 1/2" |
| ● 1984 | Steel | 1/2" |

PLAIN SPINDLE CUP

Rounded Hole

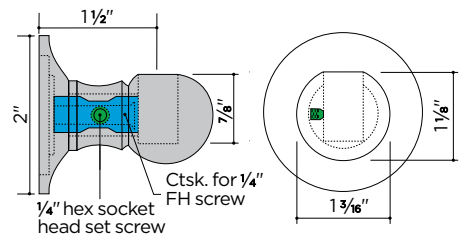

| | | Hole |
|--------|---------------|------|
| ● 883 | Bronze | 1/2" |
| ● 183 | Nickel-Silver | 1/2" |
| ● 1983 | Steel | 1/2" |

TRADITIONAL POST FASCIA FLANGE

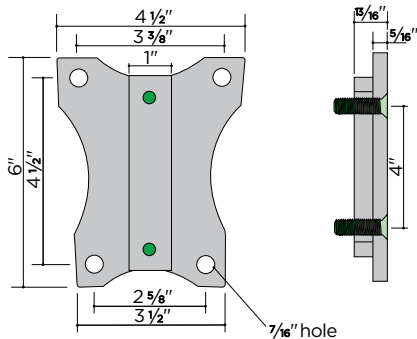

| | |
|--------|---------------|
| ● 888 | Bronze |
| ● 198 | Nickel-Silver |
| ● 1988 | Steel |



DECORATIVE HEX HEAD LAG SCREW

For mounting fascia flange

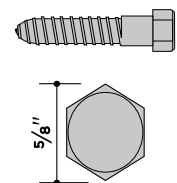

| | | |
|-----------------|---------------|-----------|
| ● Brass | Finished Head | 3/8" x 2" |
| ● Nickel-Silver | Finished Head | 3/8" x 2" |

SPINDLES

● ALUMINUM ● BRONZE ● NICKEL-SILVER ● MALLEABLE IRON / STEEL

Spindles are produced from solid stock and have a surface suitable for polishing or painting. Forged spindles with bronze and nickel-silver centers are permanently assembled and are equal in strength to solid spindles. Bronze and nickel-silver centers are polished and protected for shipment and installation. Aluminum spindles are machined from solid 6063 aluminum rod and have a surface suitable for painting or anodizing. Important: spindles are not structural members nor intended to be starting posts. Available bases, flanges and collars on pages 50-52.

42" Scale: 1" = 1'-0"

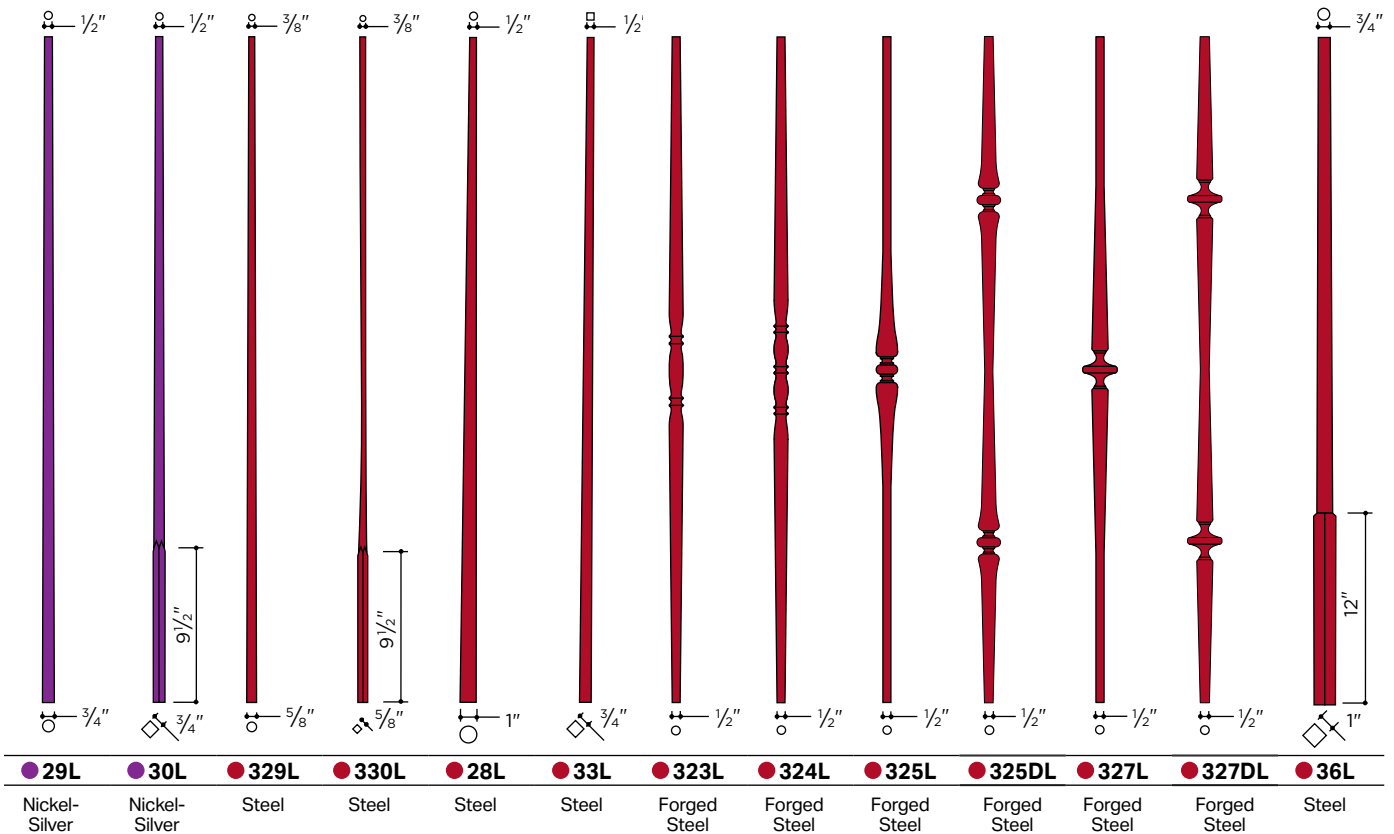
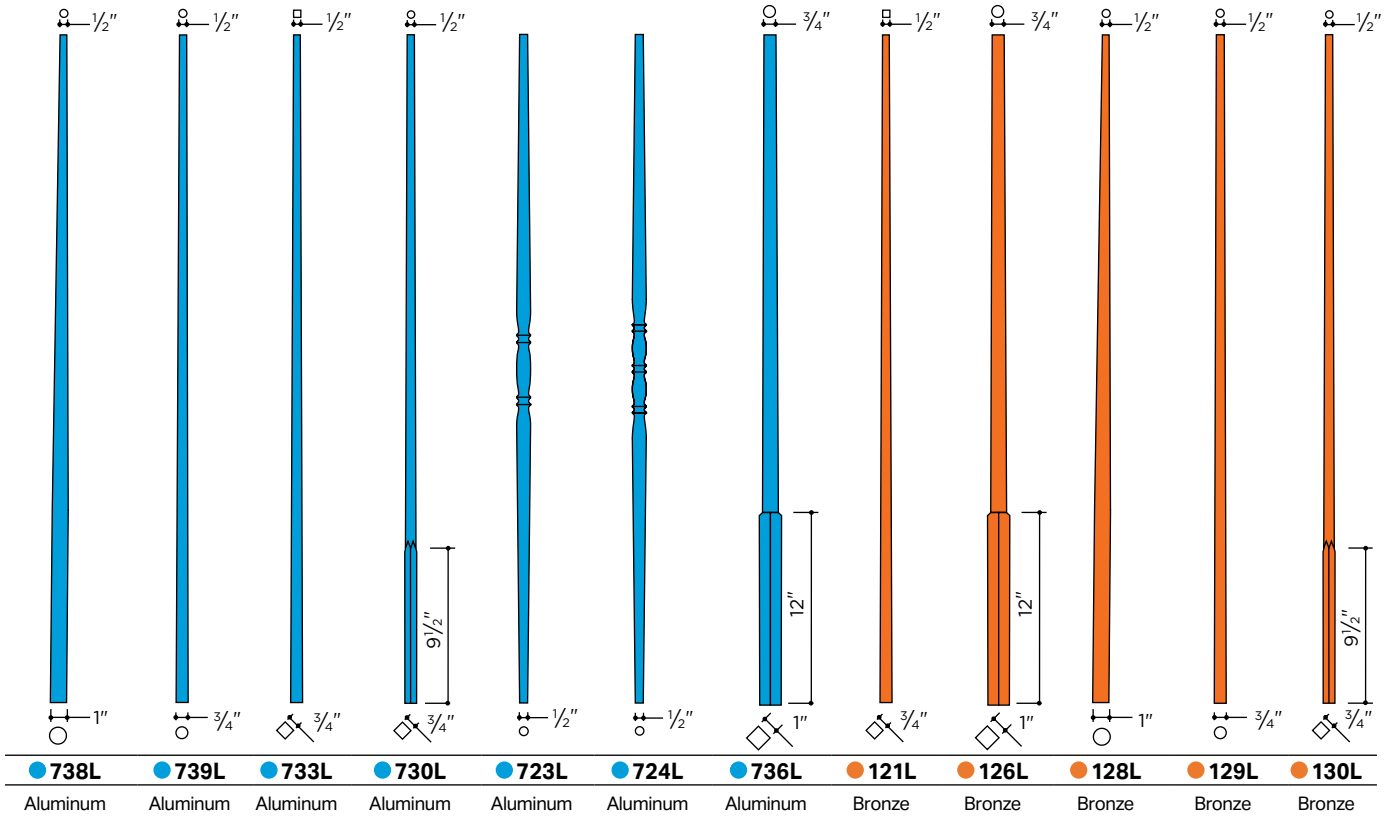

● ALUMINUM ● BRONZE ● NICKEL-SILVER ● STAINLESS ● MALLEABLE IRON / STEEL

42" Scale: 1" = 1'-0"

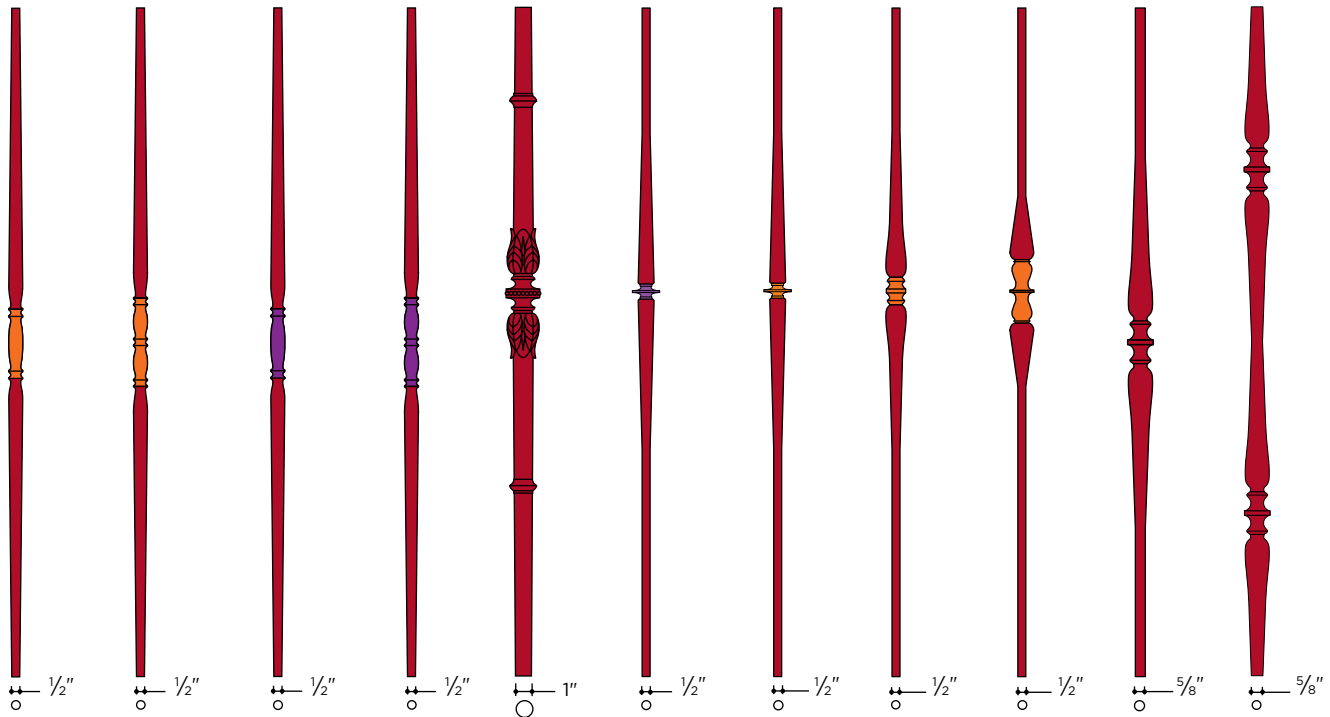

● 123L ● 124L ● 23L ● 24L ● 334L ● 336L ● 337L ● 338L ● 339L ● 328L ● 328DL

Forged Steel w/ Bronze Forged Steel w/ Bronze Forged Steel w/ Nickel-Silver Forged Steel w/ Nickel-Silver Malleable Iron Forged Steel w/ Nickel-Silver Forged Steel w/ Bronze Forged Steel w/ Bronze Forged Steel w/ Bronze Forged Steel Forged Steel

42" Scale: 1" = 1'-0"

40" Scale: 1" = 1'-0"

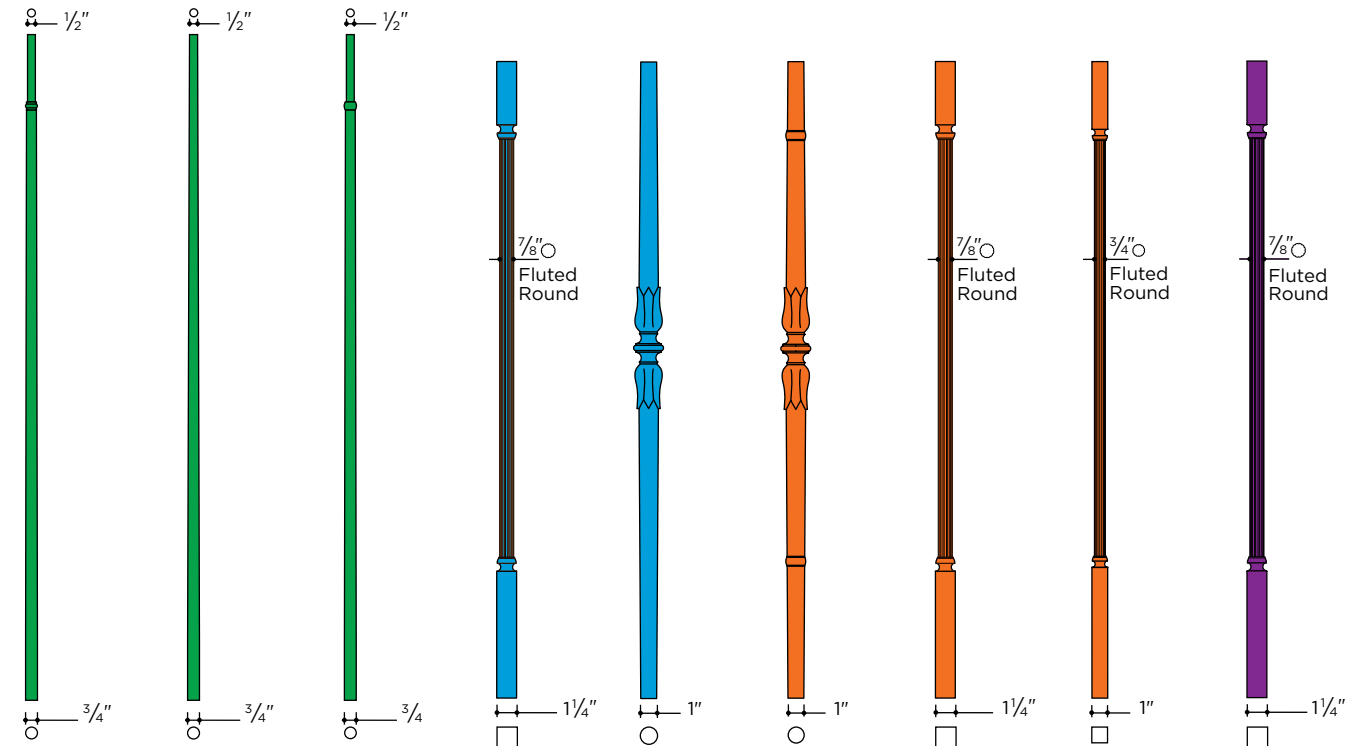

● 682L ● 683L ● 684L ● 735 ● 740 ● 234 ● 235 ● 239 ● 236

Stainless Stainless Stainless Aluminum Aluminum Bronze Bronze Bronze Nickel-Silver

● ALUMINUM ● BRONZE ● NICKEL-SILVER ● STEEL

36" Scale: 1" = 1'-0"

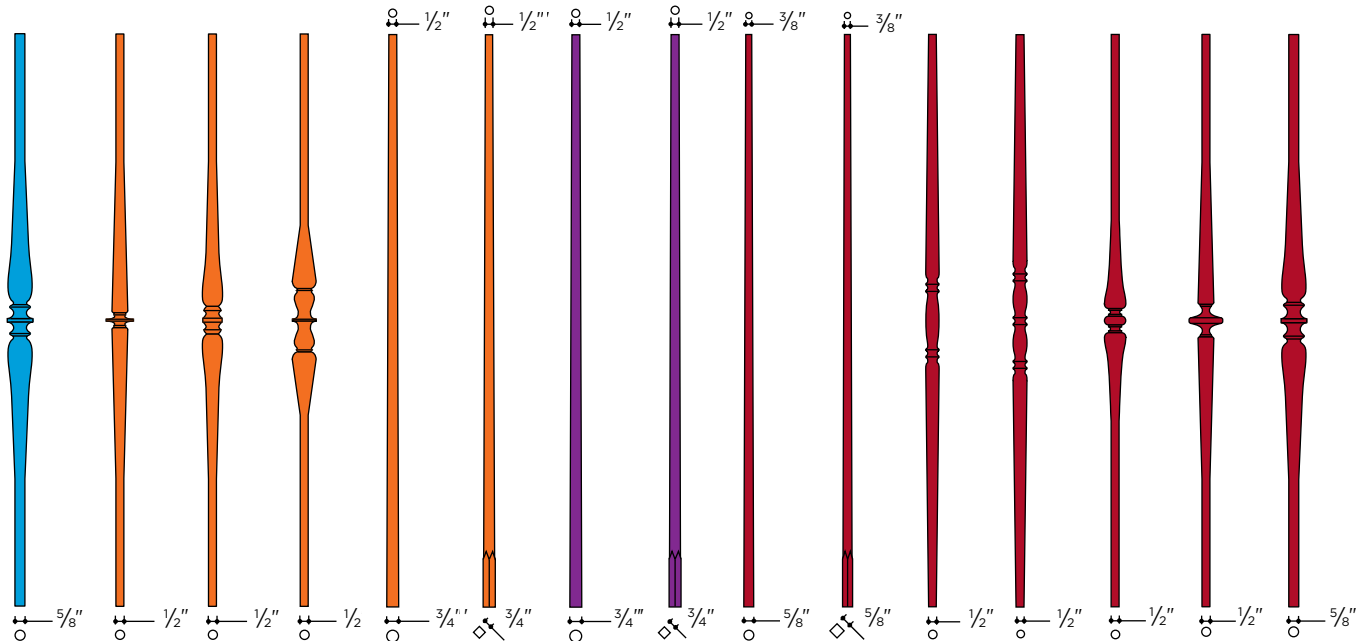

- | | | | | | | | | | | | | | | |
|----------|--------|--------|--------|--------|--------|---------------|---------------|-------|-------|--------------|--------------|--------------|--------------|--------------|
| ● 718 | ● 137 | ● 138 | ● 139 | ● 129 | ● 130 | ● 29 | ● 30 | ● 329 | ● 330 | ● 323 | ● 324 | ● 325 | ● 327 | ● 328 |
| Aluminum | Bronze | Bronze | Bronze | Bronze | Bronze | Nickel-Silver | Nickel-Silver | Steel | Steel | Forged Steel | Forged Steel | Forged Steel | Forged Steel | Forged Steel |

36" Scale: 1" = 1'-0"

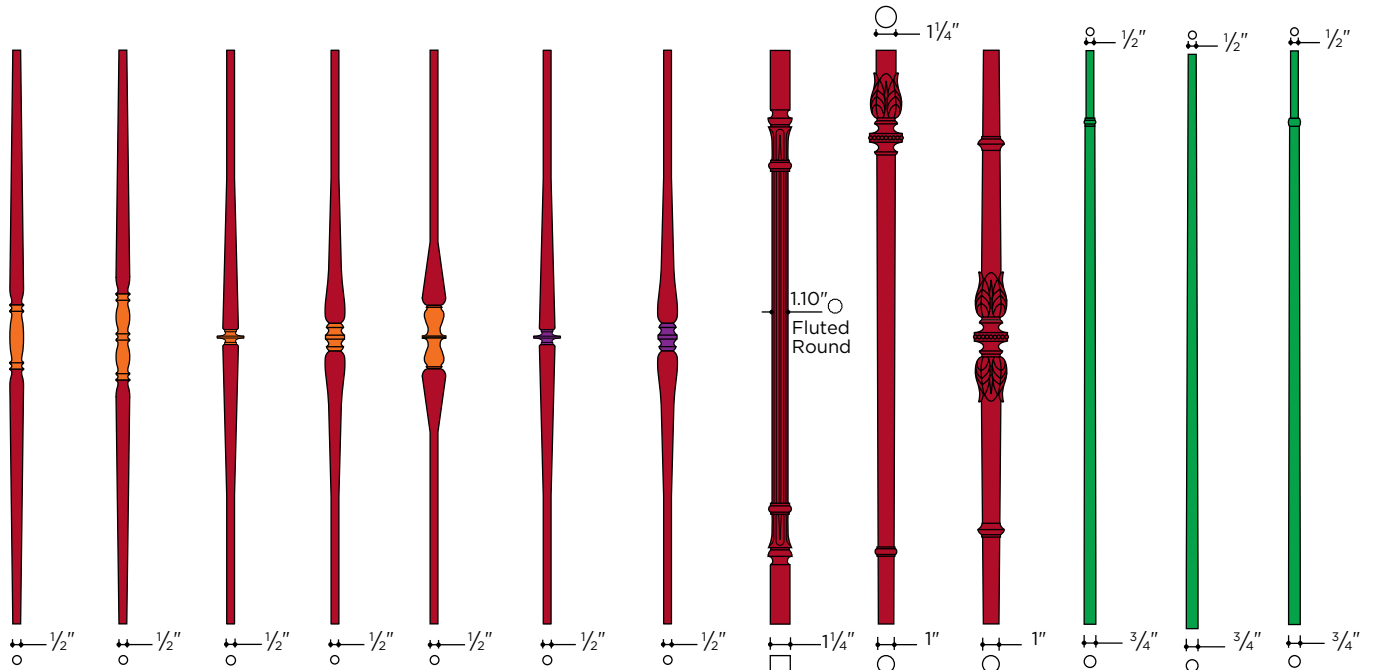

- | | | | | | | | | | | | | |
|------------------------|------------------------|------------------------|------------------------|------------------------|-------------------------------|-------------------------------|----------------|----------------|----------------|-----------|-----------|-----------|
| ● 123 | ● 124 | ● 337 | ● 338 | ● 339 | ● 336 | ● 358 | ● 335 | ● 154 | ● 334 | ● 682 | ● 683 | ● 684 |
| Forged Steel w/ Bronze | Forged Steel w/ Bronze | Forged Steel w/ Bronze | Forged Steel w/ Bronze | Forged Steel w/ Bronze | Forged Steel w/ Nickel-Silver | Forged Steel w/ Nickel-Silver | Malleable Iron | Malleable Iron | Malleable Iron | Stainless | Stainless | Stainless |

● ALUMINUM ● MALLEABLE IRON

36" Scale: 1" = 1'-0"

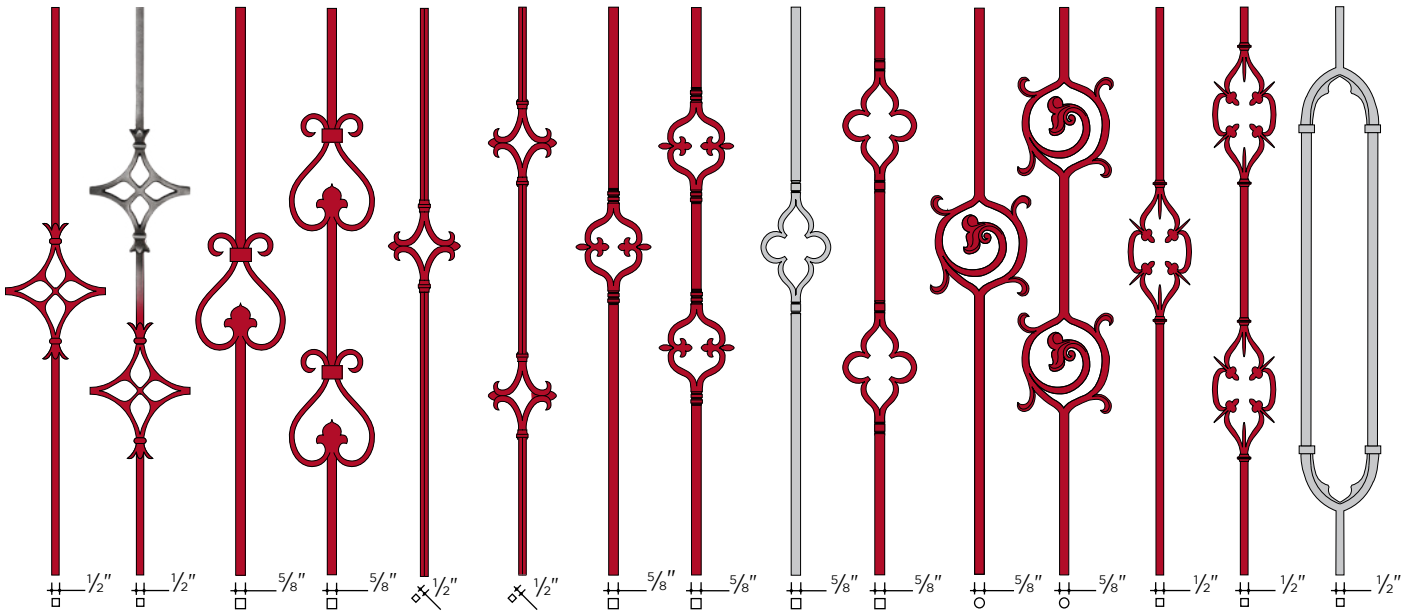

● 528 ● 158** ● 529 ● 159 ● 534 ● 153 ● 530 ● 530D ● 531 ● 531D ● 532 ● 532D ● 533 ● 533D ● 973*

Malleable Iron Malleable Iron Malleable Iron Malleable Iron Malleable Iron Malleable Iron Malleable Iron Malleable Iron Malleable Iron Malleable Iron Malleable Iron Malleable Iron Malleable Iron Malleable Iron Malleable Iron

● 1531
Aluminum

● 1973*
Aluminum

*Conforms to 4" sphere requirement
**Color removed to show detail

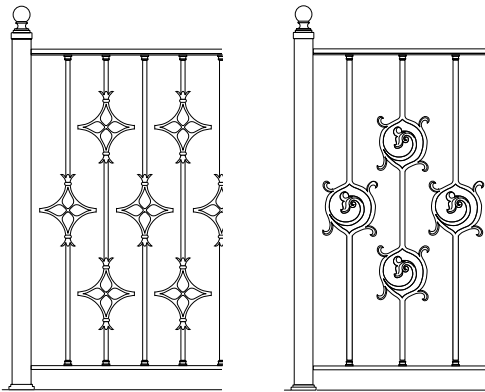

| Spindle | | Width at widest point |
|---------|----------------|-----------------------|
| ● 1973* | Aluminum | 5 1/4" |
| ● 1531 | Aluminum | 4 3/4" |
| ● 531 | Malleable Iron | 4 3/4" |
| ● 531D | Malleable Iron | 4 3/4" |
| ● 533 | Malleable Iron | 5" |
| ● 533D | Malleable Iron | 5" |
| ● 973* | Malleable Iron | 5 1/4" |
| ● 529 | Malleable Iron | 5 5/8" |
| ● 530 | Malleable Iron | 5 5/8" |

| Spindle | | Width at widest point |
|---------|----------------|-----------------------|
| ● 530D | Malleable Iron | 5 7/8" |
| ● 153 | Malleable Iron | 6" |
| ● 159 | Malleable Iron | 6" |
| ● 534 | Malleable Iron | 6" |
| ● 532 | Malleable Iron | 6 7/16" |
| ● 532D | Malleable Iron | 6 7/16" |
| ● 528 | Malleable Iron | 7" |
| ● 158 | Malleable Iron | 7" |

*Intermediate bar may be required to meet code requirements

ORNAMENTAL VALANCES

Scale: 1 1/2" = 1'-0"

These castings are useful in various combinations to create ornamental railings with minimal openings. When used with 1/2" square bars, the maximum opening will be 3 3/4", thereby conforming to the 4" sphere requirement.

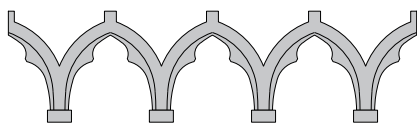

| | lbs | ht | wd |
|----------------------|-----|--------|-----|
| ● 1970 Aluminum | 1.2 | 4 5/8" | 17" |
| ● 970 Malleable Iron | 3.4 | 4 5/8" | 17" |

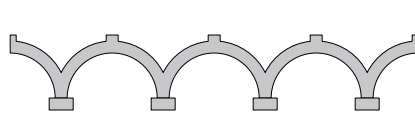

| | lbs | ht | wd |
|----------------------|-----|----|-----|
| ● 1971 Aluminum | .8 | 3" | 17" |
| ● 971 Malleable Iron | 2.2 | 3" | 17" |

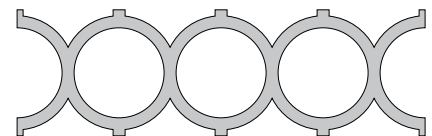

| | lbs | ht | wd |
|----------------------|-----|----|-----|
| ● 1972 Aluminum | 1.1 | 5" | 17" |
| ● 972 Malleable Iron | 3.3 | 5" | 17" |

TRADITIONAL RAILING COMPONENTS

● ALUMINUM ● BRONZE ● NICKEL-SILVER ● MALLEABLE IRON / STEEL

Bases, collars and flanges are furnished with clear holes for bar sizes shown. Non-ferrous (aluminum, bronze, nickel-silver) items are machined to match extruded sections and are satin finished, except as noted. Polished bronze and nickel-silver components are lacquered. Ferrous items are cast in malleable iron.

BASES

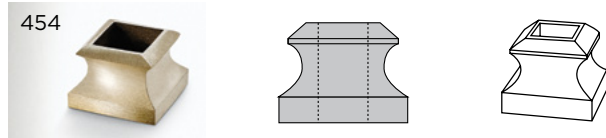

| Square Hole | | | Hole | Width | Height |
|-------------|-------|-------|--------|---------|---------|
| ● 752 | ● 252 | ● 452 | 1/2" | 1 1/4" | 15/16" |
| ● 753 | ● 253 | | 5/8" | 1 1/4" | 15/16" |
| ● 754 | ● 254 | ● 454 | 3/4" | 1 3/8" | 15/16" |
| ● 767 | ● 267 | ● 467 | 1" | 1 9/16" | 1 1/16" |
| ● 768 | ● 268 | ● 448 | 1 1/4" | 2 3/4" | 1 1/2" |
| ● 769 | ● 269 | ● 479 | 1 1/2" | 3" | 1 1/2" |

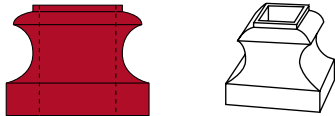

| Square Hole | | | Hole | Width | Height |
|-------------|----------------|--|--------|--------|---------|
| ● 352 | Malleable Iron | | 1/2" | 1 1/4" | 1 1/16" |
| ● 353 | Malleable Iron | | 5/8" | 1 1/4" | 1 1/16" |
| ● 354 | Malleable Iron | | 3/4" | 1 3/8" | 1 1/16" |
| ● 367 | Malleable Iron | | 1" | 1 3/4" | 1 1/8" |
| ● 368 | Malleable Iron | | 1 1/4" | 2 3/4" | 1 5/8" |
| ● 369 | Malleable Iron | | 1 1/2" | 3" | 1 3/4" |

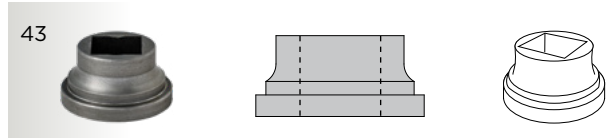

| Square Hole | | | Hole | Width | Height |
|-------------|---------------|--|------|---------|--------|
| ● 39 | Aluminum | | 3/4" | 1 9/16" | 3/4" |
| ● 47 | Bronze | | 3/4" | 1 9/16" | 3/4" |
| ● 51 | Nickel-Silver | | 3/4" | 1 9/16" | 3/4" |
| ● 43 | Steel | | 5/8" | 1 7/16" | 3/4" |

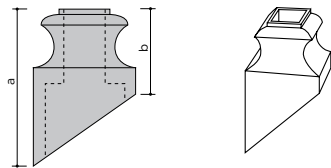

| Square Hole | | | Hole | a | b | Width |
|-------------|----------------|--|------|--------|----|--------|
| ● 362 | Malleable Iron | | 1/2" | 2" | 1" | 1 1/4" |
| ● 363 | Malleable Iron | | 5/8" | 2 1/4" | 1" | 1 1/4" |
| ● 262 | Bronze | | 1/2" | 2" | 1" | 1 1/4" |
| ● 263 | Bronze | | 5/8" | 2 1/4" | 1" | 1 1/4" |

| Round Hole | | | Hole | Height |
|------------|---------------|--|------|--------|
| ● 264 | Bronze | | 1" | 2 5/8" |
| ● 434 | Nickel-Silver | | 1" | 2 5/8" |

Matches center of 234, 340, and 341 post

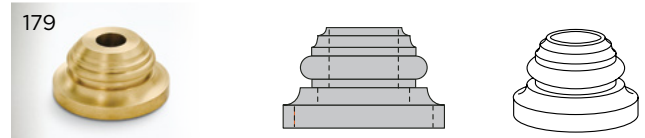
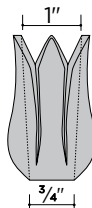

| Round Hole | | | Hole | Width | Height |
|------------|-------|--|--------|--------|--------|
| ● 182 | ● 486 | | 3/8" | 1 1/2" | 1" |
| ● 181 | ● 485 | | 1/2" | 1 1/2" | 1" |
| ● 180 | ● 484 | | 5/8" | 1 7/8" | 1 1/4" |
| ● 179 | ● 483 | | 3/4" | 3" | 1 1/2" |
| ● 178 | ● 482 | | 1" | 3" | 1 1/2" |
| ● 177 | ● 481 | | 1 1/4" | 3 1/2" | 2 1/8" |
| ● 346 | ● 300 | | 1 1/2" | 3 1/2" | 2 1/8" |

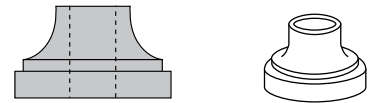

| Round Hole | | | Hole | Width | Height |
|------------|-------------------------|--|------|--------|--------|
| ● 80 | Turned Brass—unpolished | | 1/2" | 1 1/4" | 3/4" |
| ● 480 | Nickel-Silver | | 1/2" | 1 1/4" | 3/4" |
| ● 77 | Turned Steel | | 1/2" | 1 1/4" | 3/4" |
| ● 75 | Turned Steel | | 3/8" | 1 1/4" | 3/4" |

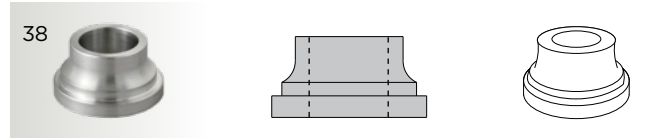

| Round Hole | | | Hole | Width | Height |
|------------|---------------|--|------|---------|--------|
| ● 38 | Aluminum | | 3/4" | 1 7/16" | 3/4" |
| ● 44 | Bronze | | 3/4" | 1 7/16" | 3/4" |
| ● 48 | Nickel-Silver | | 3/4" | 1 7/16" | 3/4" |
| ● 40 | Steel | | 5/8" | 1 1/4" | 3/4" |

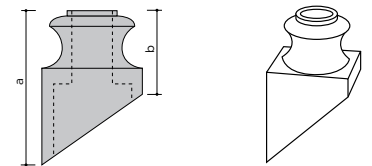

| Round Hole | | | Hole | a | b | Width |
|------------|----------------|--|------|---------|--------|--------|
| ● 359 | Malleable Iron | | 3/8" | 1 7/8" | 1" | 1 1/4" |
| ● 360 | Malleable Iron | | 1/2" | 1 7/8" | 1" | 1 1/4" |
| ● 361 | Malleable Iron | | 5/8" | 2 3/16" | 1 1/8" | 1 3/8" |
| ● 260 | Bronze | | 1/2" | 1 7/8" | 1" | 1 1/4" |
| ● 261 | Bronze | | 5/8" | 2 3/16" | 1 1/8" | 1 3/8" |
| ● 461 | Nickel-Silver | | 5/8" | 2 3/16" | 1 1/8" | 1 1/2" |

● ALUMINUM ● BRONZE ● NICKEL-SILVER ● STAINLESS ● MALLEABLE IRON/STEEL

BASES

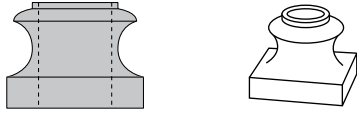

Round Hole

| Aluminum | Bronze | Nickel-Silver | Malleable Iron | Hole | Width | Height |
|----------|--------|---------------|----------------|--------|--------|--------|
| | ● 255 | | ● 355 | 3/8" | 1 1/4" | 15/16" |
| | ● 256 | ● 456 | ● 356 | 1/2" | 1 1/4" | 15/16" |
| ● 717 | ● 257 | | ● 357 | 5/8" | 1 3/8" | 1 1/8" |
| | | ● 457 | | 5/8" | 1 1/2" | 1 1/8" |
| ● 760 | ● 250 | ● 455 | | 3/4" | 2 1/2" | 15/8" |
| ● 719 | ● 249 | ● 449 | ● 349 | 1" | 2 1/2" | 15/8" |
| | ● 251 | | | 1 1/4" | 2 1/2" | 15/8" |

TUBE SOCKETS

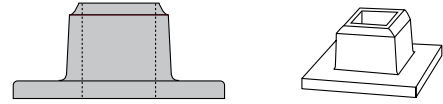

Square Hole

| Mal. Iron | Aluminum | Hole | Base | Height |
|-----------|----------|--------|--------|--------|
| ● 201 | ● 1201 | 1" | 3" | 1 3/8" |
| ● 202 | ● 1202 | 1 1/4" | 3 1/4" | 1 1/2" |
| ● 203 | ● 1203 | 1 1/2" | 3 1/2" | 1 3/4" |
| ● 204 | ● 1204 | 2" | 4" | 1 3/4" |
| ● 205 | ● 1205 | 2 1/2" | 4 1/2" | 1 7/8" |
| ● 206 | ● 1206 | 3" | 5 1/4" | 2 3/8" |

TRADITIONAL RAILING COMPONENTS

FLANGES



Round Hole

| Bronze | Turned Steel | Hole | Width | Height |
|--------|--------------|--------|--------|--------|
| ● 147 | ● 347 | 1 1/2" | 2 1/4" | 3/4" |

Square Hole

| | | Hole | Base | Height |
|--------|----------------|-------|---------|---------|
| ● 342 | Malleable Iron | 7/16" | 1 1/8" | 1 1/8" |
| ● 344* | Malleable Iron | 1/2" | 1 1/8" | 1 1/8" |
| ● 350* | Malleable Iron | 1/2" | 1 1/8" | 1 3/16" |
| ● 351 | Malleable Iron | 5/8" | 1 3/16" | 1 3/16" |
| ● 398 | Malleable Iron | 3/4" | 1 7/16" | 7/8" |
| ● 400 | Malleable Iron | 7/8" | 1 5/8" | 1" |
| ● 399 | Malleable Iron | 1" | 1 3/4" | 1 1/8" |

* 344 is similar to 350 but is high enough to permit adjustment of baluster height for uneven steps

Round Hole

| | Hole | Width | Height |
|-----------------|--------|--------|---------|
| ● 690 Stainless | 1 1/2" | 3 1/4" | 2 7/16" |

Square Hole

| Mal. Iron | Hole | Base | Height |
|-----------|------|----------|---------|
| ● 390 | 1/2" | 1 5/16" | 1" |
| ● 391 | 5/8" | 1 5/16" | 1" |
| ● 393 | 1" | 1 13/16" | 1 3/16" |

Round Hole

| | Hole | Width | Height |
|-----------------|------|-------|--------|
| ● 694 Stainless | 3/4" | 2" | 1 1/2" |

Round Hole

| | Hole | Width | Height |
|-----------------|--------|--------|----------|
| ● 691 Stainless | 1 1/2" | 3 1/4" | 1 13/16" |

Round Hole

| | Hole | Width | Height |
|-----------------|------|-------|----------|
| ● 695 Stainless | 3/4" | 2" | 1 13/16" |

Round Hole

| Mal. Iron | Aluminum | Bronze | Hole | Base | Height |
|-----------|----------|--------|------|---------|--------|
| ● 395 | | | 3/8" | 1 5/16" | 1" |
| ● 396 | ● 776 | ● 276 | 1/2" | 1 5/16" | 1" |
| ● 397 | ● 797 | ● 297 | 5/8" | 1 7/16" | 1 1/8" |

● ALUMINUM ● BRONZE ● NICKEL-SILVER ● MALLEABLE IRON/STEEL



Oyler School, Cincinnati, OH, Bluegrass Iron Works, Ludlow, KY (Fabricator), Steve Hollingsworth, KY (Designer).



282

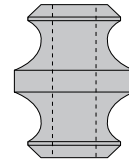

Round Hole

| | | Hole | Width | Height |
|-------|---------------|------|--------|--------|
| ● 281 | Bronze | 1/2" | 1 1/4" | 1 3/4" |
| ● 282 | Bronze | 5/8" | 1 1/4" | 1 3/4" |
| ● 406 | Nickel-Silver | 5/8" | 1 1/4" | 1 3/4" |

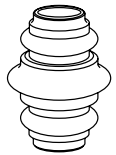
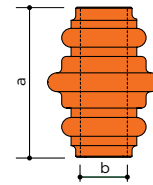

Round Hole

| | | Hole | Width | Height |
|-------|--------|------|--------|--------|
| ● 310 | Bronze | 1/2" | 1 1/2" | 2" |
| ● 311 | Bronze | 5/8" | 1 1/2" | 2" |

COLLARS

Bronze, nickel silver and steel collars can be used to add decoration to square or round bar. Bronze and nickel-silver collars are polished and clear lacquered.



366

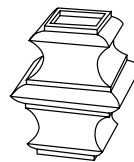
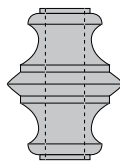
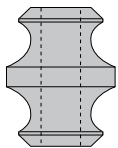

Square Hole

| Aluminum | Bronze | Hole | Width | Height |
|----------|--------|------|--------|--------|
| ● 765 | ● 265 | 1/2" | 1 3/8" | 1 3/4" |
| ● 766 | ● 266 | 5/8" | 1 3/8" | 1 3/4" |

Square Hole

| | | Hole | Width | Height |
|-------|----------------|------|----------|--------|
| ● 365 | Malleable Iron | 1/2" | 1 9/16" | 2" |
| ● 366 | Malleable Iron | 5/8" | 1 11/16" | 1 7/8" |
| ● 348 | Malleable Iron | 3/4" | 1 15/16" | 2" |
| ● 866 | Bronze | 5/8" | 1 11/16" | 1 7/8" |

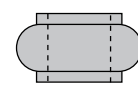

Round Hole, Turned

| Steel | Bronze | Nickel-Silver | Hole OD | Height | |
|-------|--------|---------------|---------|--------|-------|
| ● 72 | ● 272 | ● 472 | 1/2" | 1" | 9/16" |
| ● 273 | ● 473 | | 1" | 1 1/4" | 3/4" |

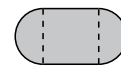

Round Hole, Turned

| Steel | Bronze | Nickel-Silver | Hole OD | Height | |
|-------|--------|---------------|---------|--------|--------|
| ● 73 | ● 872 | | 3/8" | 3/4" | 13/32" |
| ● 74 | ● 274 | ● 474 | 5/8" | 1" | 1/2" |

● ALUMINUM ● BRONZE ● NICKEL-SILVER ● MALLEABLE IRON / STEEL



Oyler School, Cincinnati, OH, Bluegrass Iron Works, Ludlow, KY (Fabricator), Steve Hollingsworth, KY (Designer).

TRADITIONAL RAILING COMPONENTS

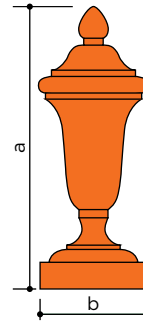

| Square Base | | a | b |
|-------------|--------|----|--------|
| ● 3134 | Bronze | 4" | 1 1/2" |
| ● 3133 | Bronze | 3" | 1" |

| Round Base | | a | b |
|------------|--------|----|--------|
| ● 3034 | Bronze | 4" | 1 1/2" |
| ● 3033 | Bronze | 3" | 1" |

URN AND BALL FINIALS

Bronze, nickel-silver and aluminum urns and finials are satin-finished. Bronze and nickel-silver items are clear lacquered. All urns and finials are supplied with a 3/8" tapped hole in the base. Finial and urn bases, see page 40.

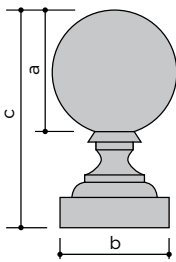

| Square Base | | a | b | c |
|-------------|-----------|--------|--------|--------|
| ● 3145 | Bronze | 2" | 1 3/4" | 3 1/2" |
| ● 3144 | Bronze | 1 3/4" | 1 1/2" | 3 1/8" |
| ● 3143 | Bronze | 1 1/2" | 1 1/4" | 2 3/4" |
| ● 3142 | Bronze | 1 1/4" | 1 1/8" | 2 3/8" |
| ● 3545 | Mal. Iron | 2" | 1 3/4" | 3 1/2" |
| ● 3544 | Mal. Iron | 1 3/4" | 1 1/2" | 3 1/8" |
| ● 3543 | Mal. Iron | 1 1/2" | 1 1/4" | 2 3/4" |
| ● 3542 | Mal. Iron | 1 1/4" | 1 1/8" | 2 3/8" |
| ● 3541 | Mal. Iron | 1" | 7/8" | 1 3/4" |

| Round Base | | a | b | c |
|------------|----------|--------|--------|--------|
| ● 3243 | Aluminum | 1 1/2" | 1 1/4" | 2 3/4" |
| ● 3045 | Bronze | 2" | 1 3/4" | 3 1/2" |
| ● 3044 | Bronze | 1 3/4" | 1 1/2" | 3 1/8" |
| ● 3043 | Bronze | 1 1/2" | 1 1/4" | 2 3/4" |
| ● 3042 | Bronze | 1 1/4" | 1 1/8" | 2 3/8" |
| ● 3041 | Bronze | 1" | 7/8" | 1 3/4" |

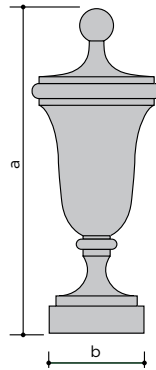

| Square Base | | a | b |
|-------------|----------------|----|--------|
| ● 3323 | Aluminum | 3" | 1" |
| ● 3126 | Bronze | 6" | 1 3/4" |
| ● 3125 | Bronze | 5" | 1 1/2" |
| ● 3124 | Bronze | 4" | 1 1/4" |
| ● 3123 | Bronze | 3" | 1" |
| ● 3526 | Malleable Iron | 6" | 1 3/4" |
| ● 3525 | Malleable Iron | 5" | 1 1/2" |
| ● 3524 | Malleable Iron | 4" | 1 1/4" |
| ● 3523 | Malleable Iron | 3" | 1" |

| Round Base | | a | b |
|------------|---------------|----|--------|
| ● 3025 | Bronze | 5" | 1 1/2" |
| ● 3024 | Bronze | 4" | 1 1/4" |
| ● 3023 | Bronze | 3" | 1" |
| ● 4024 | Nickel-Silver | 4" | 1 1/4" |

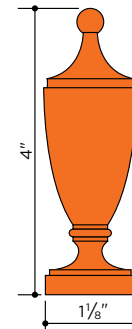

| Round Base | | a | b |
|------------|--------|----|--------|
| ● 3064 | Bronze | 4" | 1 1/8" |

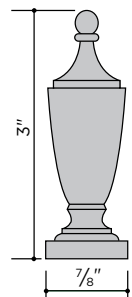

| Round Base | | a | b |
|------------|----------|----|------|
| ● 3277† | Aluminum | 3" | 7/8" |
| ● 3073 | Bronze | 3" | 7/8" |

† Unpolished

● ALUMINUM ● BRONZE ● NICKEL-SILVER ● MALLEABLE IRON



All castings are double-faced

CAST ROSETTES

Thickness: Approx. 1/4"
Burnished, except as noted

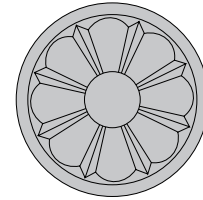

| | OD |
|------------------------|--------|
| ● 2454 Aluminum | 2 3/4" |
| ● 2654 Bronze | 2 3/4" |
| ● 1654 Nickel-Silver | 2 3/4" |
| ● 2554* Malleable Iron | 2 3/4" |

* As Cast

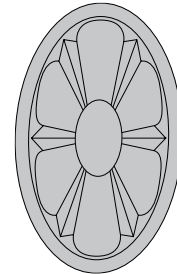

| | OD |
|------------------------|-------------------|
| ● 2453 Aluminum | 3 5/16" x 2 1/16" |
| ● 2653 Bronze | 3 5/16" x 2 1/16" |
| ● 1653 Nickel-Silver | 3 5/16" x 2 1/16" |
| ● 2553* Malleable Iron | 3 1/2" x 2 3/16" |

* As Cast



| | OD |
|------------------------|--------|
| ● 6603 Bronze | 1 3/4" |
| ● 1603 Nickel-Silver | 1 3/4" |
| ● 6203* Malleable Iron | 1 3/4" |

* As Cast

SPINDLE TOPS

Spindle tops may be used above and/or below 1/2" square bar and may be adjusted to any angle. Scale: 3" = 1'-0"

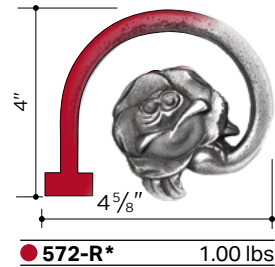
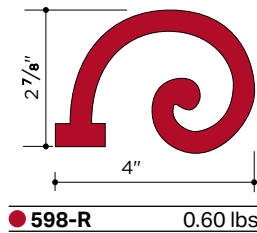
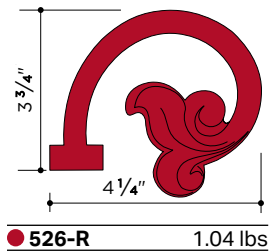

* Color removed to show detail

PICKETS

Shanks: 1" lengths
All castings are double-faced

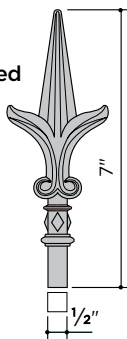

● 54 Malleable Iron

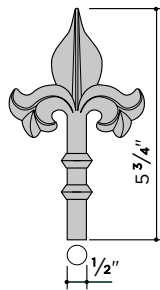

● 12 Malleable Iron

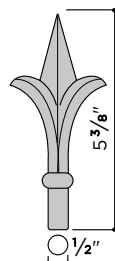

● 4 Malleable Iron



| | OD |
|------------------------|--------|
| ● 6601 Bronze | 1 7/8" |
| ● 1601 Nickel-Silver | 1 7/8" |
| ● 6201* Malleable Iron | 1 7/8" |

* As Cast



BALL CAPS

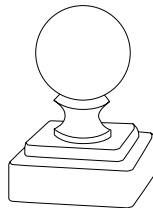
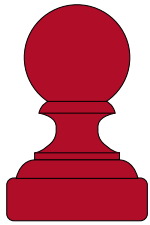

Rounded inside corners

| | | Tube Size | Ball Diam. | Height |
|--------|----------------|-------------------------------------------------------------------|-----------------------------------|---------------------------------|
| ● 5320 | Malleable Iron | 2" x 2" | 1 ¹³ / ₁₆ " | 3 ³ / ₄ " |
| ● 5325 | Malleable Iron | 2 ¹ / ₂ " x 2 ¹ / ₂ " | 2 ¹ / ₈ " | 4 ¹ / ₈ " |
| ● 5330 | Malleable Iron | 3" x 3" | 2 ³ / ₁₆ " | 4 ⁵ / ₈ " |
| ● 5335 | Malleable Iron | 3 ¹ / ₂ " x 3 ¹ / ₂ " | 2 ¹ / ₂ " | 5 ¹ / ₈ " |
| ● 5340 | Malleable Iron | 4" x 4" | 2 ³ / ₄ " | 5 ¹ / ₂ " |

CAP TYPE A

Type A bronze and aluminum caps are satin finished. Cast aluminum caps are Almag 35. Bronze caps are cast from C86500 bronze—to match closely the color of extruded architectural bronze—and are lacquered.

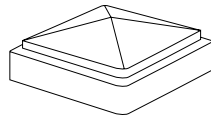
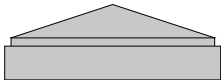

Rounded inside corners

| | | Tube Size | Satin Finish | Tube Size |
|---------|-----------|-------------------------------------------------------------------|--------------|---------------------|
| ● 5615 | Mal. Iron | 1 ¹ / ₂ " x 1 ¹ / ₂ " | ● 5720 | Cast Bronze 2" x 2" |
| ● 5620 | Mal. Iron | 2" x 2" | ● 5730 | Cast Bronze 3" x 3" |
| ● 5625 | Mal. Iron | 2 ¹ / ₂ " x 2 ¹ / ₂ " | ● 5740 | Cast Bronze 4" x 4" |
| ● 5632 | Mal. Iron | 3" x 2" | ● 5784 | Cast Bronze 8" x 4" |
| ● 5630 | Mal. Iron | 3" x 3" | | |
| ● 5635 | Mal. Iron | 3 ¹ / ₂ " x 3 ¹ / ₂ " | | |
| ● 5640 | Mal. Iron | 4" x 4" | | |
| ● 5642 | Mal. Iron | 4" x 2" | | |
| ● 56425 | Mal. Iron | 4" x 2 ¹ / ₂ " | | |
| ● 5643 | Mal. Iron | 4" x 3" | | |
| ● 5652 | Mal. Iron | 5" x 2" | | |
| ● 56525 | Mal. Iron | 5" x 2 ¹ / ₂ " | | |
| ● 5653 | Mal. Iron | 5" x 3" | ● 5820 | Cast Alum. 2" x 2" |
| ● 5650 | Mal. Iron | 5" x 5" | ● 5830 | Cast Alum. 3" x 3" |
| ● 5663 | Mal. Iron | 6" x 3" | ● 5840 | Cast Alum. 4" x 4" |
| ● 5664 | Mal. Iron | 6" x 4" | ● 5863 | Cast Alum. 6" x 3" |
| ● 5660 | Mal. Iron | 6" x 6" | ● 5864 | Cast Alum. 6" x 4" |
| ● 5683 | Mal. Iron | 8" x 3" | ● 5883 | Cast Alum. 8" x 3" |
| ● 5684 | Mal. Iron | 8" x 4" | ● 5884 | Cast Alum. 8" x 4" |

DRIVE-ON CAP

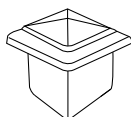
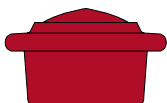

| | | |
|--------|-----------|-----------------------------------------------|
| ● 5411 | Mal. Iron | Drive fit for 1" x 1" .073" structural tubing |
|--------|-----------|-----------------------------------------------|

CAP TYPE C

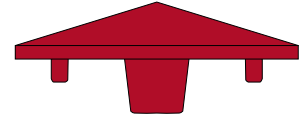

| | | Tube Size* |
|--------|----------------|-------------------------------------------------------------------|
| ● 5415 | Malleable Iron | 1 ¹ / ₂ " x 1 ¹ / ₂ " |
| ● 5440 | Malleable Iron | 4" x 4" |

* 11 ga. maximum thickness

CAP TYPE D

Type D Post Caps are extruded and machined from aluminum alloy 6063 and are suitable for anodizing. Lugs fit inside ¹/₈" wall tubing with sharp corners and are easily ground down to fit ³/₁₆" or ¹/₄" wall tubing.

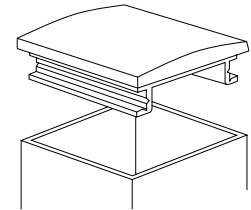
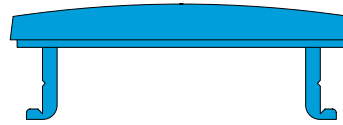

| | | Tube Size |
|--------|-------------------|-----------|
| ● 5120 | Extruded Aluminum | 2" x 2" |
| ● 5130 | Extruded Aluminum | 3" x 3" |
| ● 5132 | Extruded Aluminum | 3" x 2" |
| ● 5140 | Extruded Aluminum | 4" x 4" |
| ● 5142 | Extruded Aluminum | 4" x 2" |
| ● 5143 | Extruded Aluminum | 4" x 3" |
| ● 5152 | Extruded Aluminum | 5" x 2" |
| ● 5153 | Extruded Aluminum | 5" x 3" |
| ● 5162 | Extruded Aluminum | 6" x 2" |
| ● 5163 | Extruded Aluminum | 6" x 3" |
| ● 5164 | Extruded Aluminum | 6" x 4" |
| ● 5183 | Extruded Aluminum | 8" x 3" |
| ● 5184 | Extruded Aluminum | 8" x 4" |

DRIVE-ON CAP, TYPE W

For drive fit. Caps do not require fastening. 18 ga.

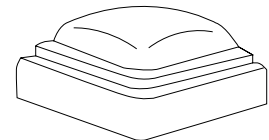

| | | Tube Size |
|--------|-------------------------|-------------------------------------------------------------------|
| ● 5920 | Pressed Steel | 2" x 2" |
| ● 5925 | Pressed Steel | 2 ¹ / ₂ " x 2 ¹ / ₂ " |
| ● 5930 | Pressed Steel | 3" x 3" |
| ● 5935 | Pressed Steel | 3 ¹ / ₂ " x 3 ¹ / ₂ " |
| ● 5943 | Pressed Steel | 4" x 3" |
| ● 5940 | Pressed Steel | 4" x 4" |
| ● 5963 | Pressed Steel | 6" x 3" |
| ● 5933 | Pressed Stainless Steel | 3" x 3" |
| ● 5944 | Pressed Stainless Steel | 4" x 4" |

TREILLAGE AND ORNAMENTAL RAILING PANELS



Private Residence, MA, Make Architectural Metalworking, West Wareham, MA (Fabricator),
Platemark, Boston, MA (Architect), FBN Construction, Hyde Park, MA (General Contractor).

ORNAMENTAL RAILING PANELS

Julius Blum & Co., Inc.'s malleable iron railing panels are also used to provide architectural details on both stairs and straight runs. Some of the panels have been slightly redesigned to meet current code requirements.

ORNAMENTAL COLLARS

Designed to fit over $\frac{1}{2}$ " or $\frac{5}{8}$ " square bars, ornamental collars are a cost effective way of providing details to a stair, fence, or gate. A wide variety of design options are possible using a combination of ornamental collars.

TREILLAGE

All Julius Blum & Co., Inc. treillage panels are double-faced and superbly detailed. Because they are malleable iron, they may be welded and bent cold and will not break or shatter in the course of normal handling.

Many of the Julius Blum Treillage patterns are available in both aluminum and malleable iron. Aluminum castings are recommended where it is important to keep weight at a minimum, as in gates or removable screens. Otherwise, malleable iron castings are preferred for their strength and resistance to breakage. All castings are double-faced and cleanly finished. Made in USA.

- **Aluminum** items are cast from Almag 35. Anodizing of aluminum panels is not recommended as the material will not anodize consistently and will not match the color of anodized extruded aluminum.
- **Malleable Iron** is similar in weight, feel, and appearance to gray iron—commonly known as cast iron. Gray iron is suitable for small, simple

pieces such as post caps or heavy, solid pieces such as manhole covers. It is not suitable for delicate ornamental cast patterns such as scrolls and flowers. Gray iron is brittle and shatters easily when dropped or hit and is subject to cracking when exposed to uneven heat during welding. Malleable iron will not break or shatter in the course of ordinary handling or shipping and withstands considerable abuse. To some degree, malleable iron castings can be bent cold, and they are easily welded. The special properties of malleable iron are produced by heat treating.

Malleable Iron Castings are not priced to compete with gray iron castings. Despite the unsuitability of gray iron for intricate ornamental castings, many ornamental

patterns are offered in this cheaper material. Since the manufacture of gray iron castings requires fewer operations than heat-treated malleable iron, and since they are not finished with the care of Julius Blum ornamental castings, they can be sold for less. However, breakage during shipping, fabrication, installation, and everyday use often eradicats savings from the initial lower cost. In the long run, the permanence and quality of the final product make malleable iron more desirable. When panels are assembled into screens spanning more than three panels' width or height, it is important to provide adequate intermediate supports.

All items are carried in stock in substantial quantities and are available for prompt shipment.

● MALLEABLE IRON

CAMBRIDGE

Ornamental Panels

The four elements of the Cambridge design can be combined in many different ways to form panels, columns or friezes. The castings are cored to slide over a 1/2" square bar.

● **596** 3.6 lbs
Ht: 10 1/8" Wd: 8"

● **597** 2.6 lbs
Ht: 9 5/16" Wd: 8"

● **598** 2.8 lbs
Ht: 6 3/16" Wd: 8"

● **599** 4.1 lbs
Ht: 11 7/8" Wd: 8"

● **596** 3.6 lbs
Ht: 10 1/8" Wd: 8"

● **597** 2.6 lbs
Ht: 9 5/16" Wd: 8"

● **598** 2.8 lbs
Ht: 6 3/16" Wd: 8"

● **599** 4.1 lbs
Ht: 11 7/8" Wd: 8"

Dimensions for column assembly:
7 1/16"
6 3/16"
8"
10 1/8"
1/2" sq. bar

EMPIRE

For 1/2" square bar. Diamond-shaped cross section gives these panels a distinctive style.

● **963** 1.76 lbs
Ht: 11" Wd: 8"

● **964** 2.03 lbs
Ht: 11" Wd: 8"

● **965** 2.72 lbs
Ht: 11" Wd: 8"

● **967** 1.04 lbs
Ht: 5 1/2" Wd: 5 1/4"

● **968** 1.14 lbs
Ht: 5 1/2" Wd: 5 1/4"

● **969** .82 lbs
Ht: 5" Wd: 5"

TYPICAL SECTION THROUGH COLLARS

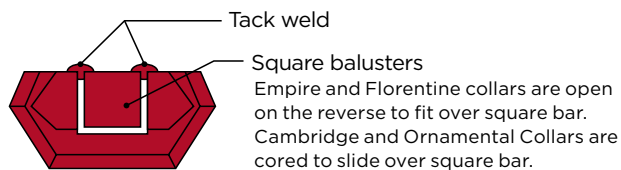

FLORENTINE

Railing Panels

For 1/2" square bar, except as noted

Florentine collars are open on one side for easy installation over square bar by tack welding.

● **559** 3.0 lbs
Ht: 15" Wd: 7"

● **560** 3.6 lbs
Ht: 16" Wd: 8 1/2"

● **561** 1.9 lbs
Ht: 12" Wd: 8 1/2"

● **562*** 3.8 lbs
Ht: 15" Wd: 7"

● **563*** 3.9 lbs
Ht: 16" Wd: 8 1/2"

● **564*** 2.6 lbs
Ht: 12" Wd: 8 1/2"

* For 5/8" square bar

● **565** 3.3 lbs
Ht: 15" Wd: 8 1/2"

● **566** 2.9 lbs
Ht: 16" Wd: 7"

● **567** 3.3 lbs
Ht: 16" Wd: 8 1/2"

FLORENTINE ORNAMENTAL COLLARS †

These collars are cored to slide over 1/2" square bar except as noted. Collars are easily applied and can be fastened by screws or by tack welding.

● **543** .870 lbs
Ht: 4 3/4" Wd: 4 1/2"

● **544** .685 lbs
Ht: 4 3/4" Wd: 3"

● **546** .767 lbs
Ht: 7 3/4" Wd: 3"

● **535*** 1.160 lbs
Ht: 4 7/8" Wd: 4 1/2"

● **545*** .686 lbs
Ht: 4 3/4" Wd: 3"

● **547*** .865 lbs
Ht: 7 3/4" Wd: 3"

† Scale: 2 1/2" = 1" - 0" * For 5/8" square bar

TREILLAGE AND ORNAMENTAL RAILING PANELS

All castings are double-faced. Scale: 1 1/2" = 1'-0"

● ALUMINUM ● MALLEABLE IRON

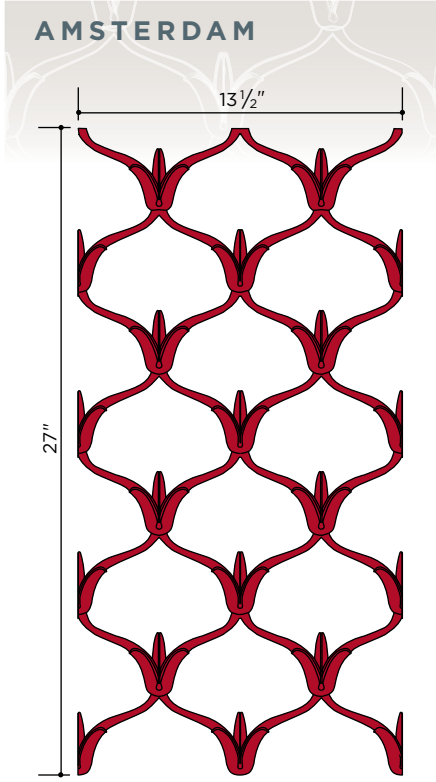

● 590 Malleable Iron 10.5 lbs

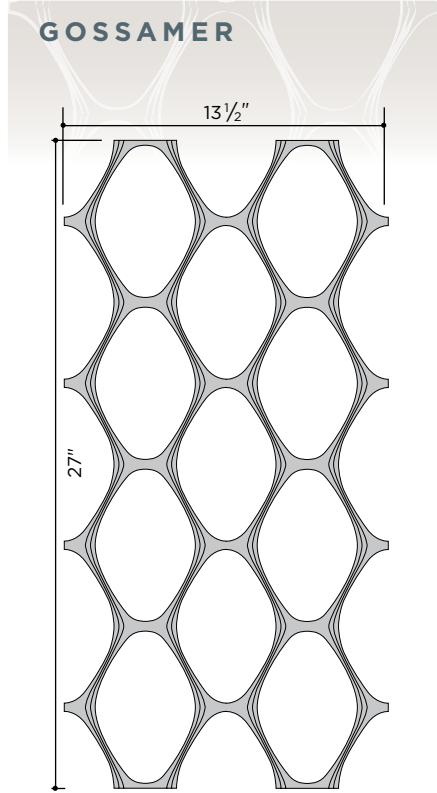

● 1585 Aluminum 3.4 lbs
● 585 Malleable Iron 10.2 lbs

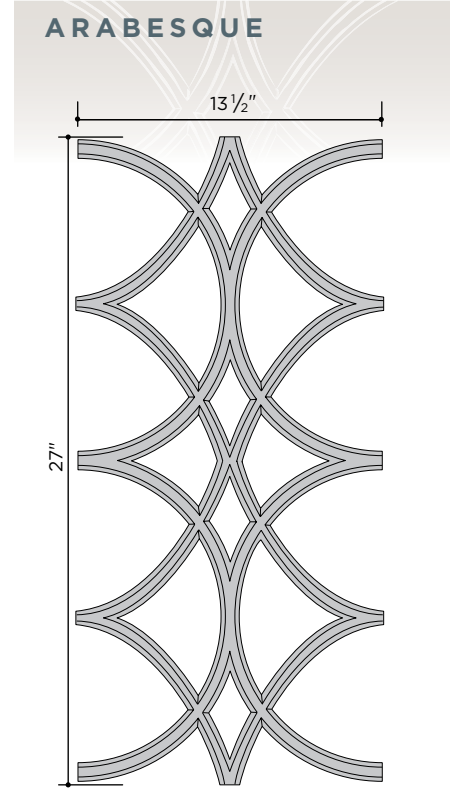

● 1961 Aluminum 2.6 lbs
● 961 Malleable Iron 7.7 lbs

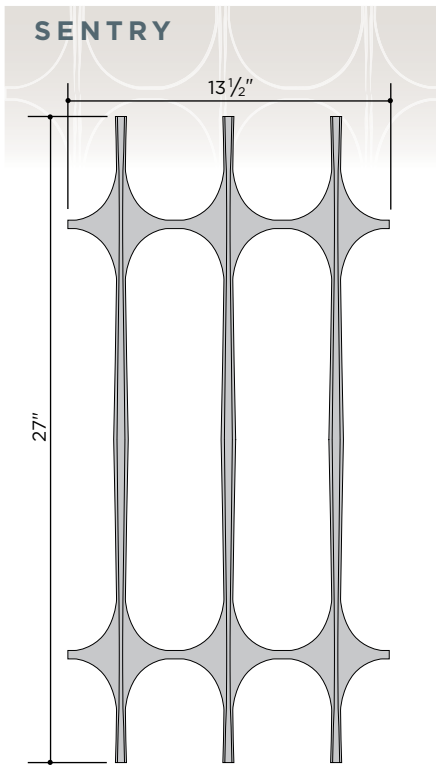

● 1579 Aluminum 2.8 lbs
● 579 Malleable Iron 8.4 lbs

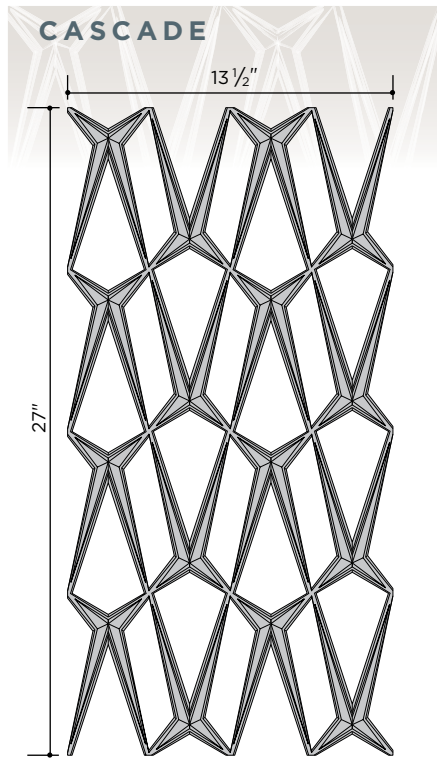

● 1583 Aluminum 4.3 lbs
● 583 Malleable Iron 12.8 lbs

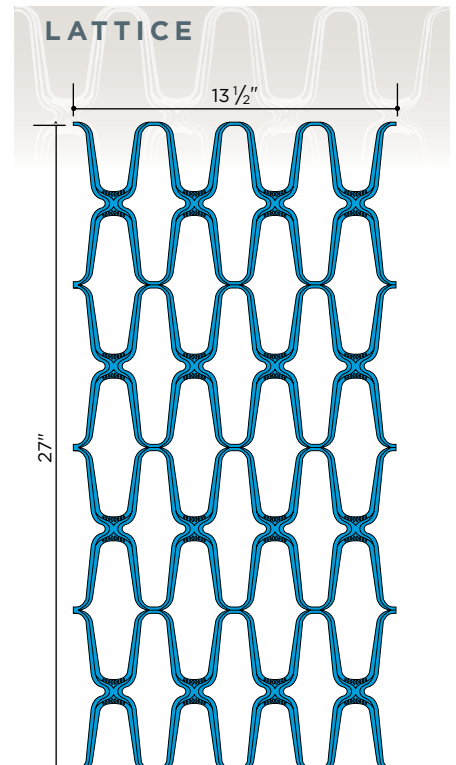

● 1508 Aluminum 3.1 lbs

● ALUMINUM ● MALLEABLE IRON

All castings are double faced. Scale: 1 1/2" = 1'-0", except as noted.

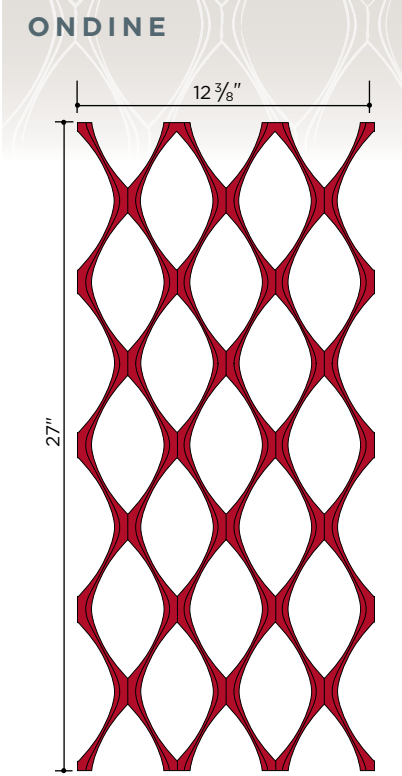

● 960 Mal. Iron 7.9 lbs

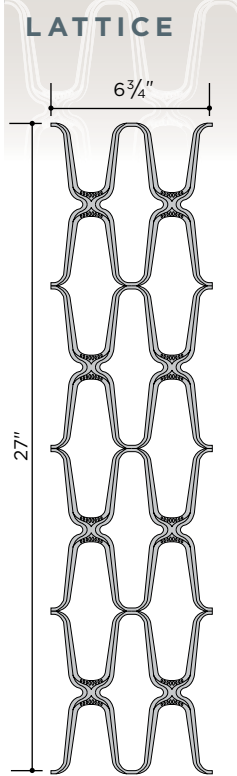

● 1504 Aluminum 1.5 lbs
● 504 Mal. Iron 4.5 lbs

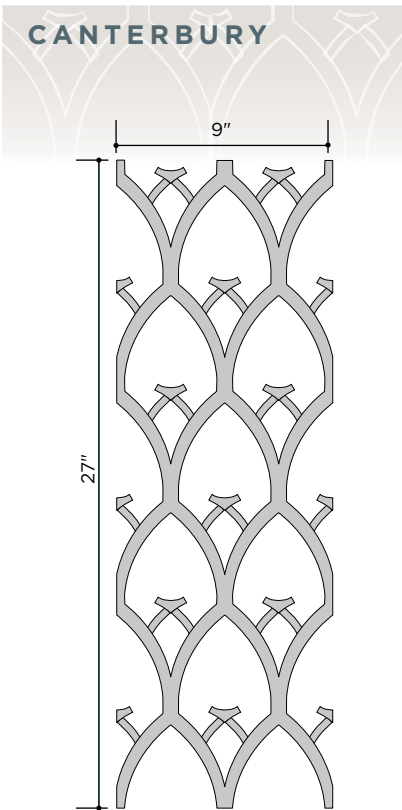

● 1589 Aluminum 3.0 lbs
● 589 Mal. Iron 8.8 lbs

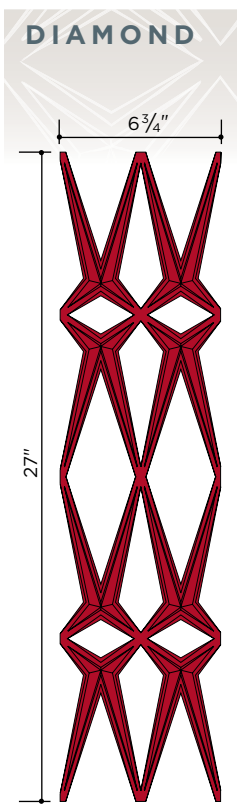

● 542 Mal. Iron 6.4 lbs

TRECENTO
Trecento panel 1963 dovetails with mullions 6433 or 6432. Panels can be arranged in continuous runs or make right-angle turns, tees, or crosses. Panels can be stacked to form solid screens or separated by lengths of filler rod 6431 to achieve a more open effect. Filler rod 6431 may also be used to close the recess in the exposed sides of the mullion. Panels may be locked into position by tack welding, caulking, set screws, or pins.

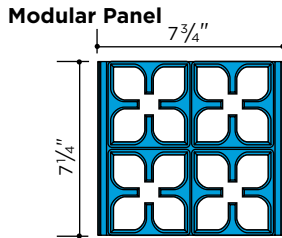

● 1963 Aluminum .80 lb/ft

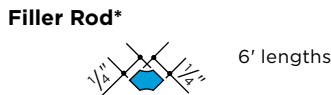

● 6431 Aluminum .063 lb/ft
*Scale: 6" = 1'-0"

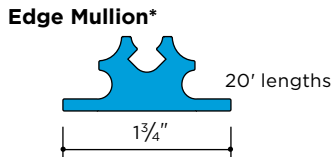

● 6432 Aluminum .660 lb/ft

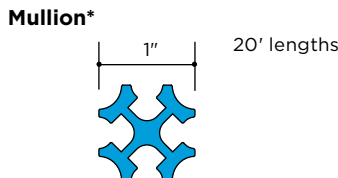

● 6433 Aluminum .493 lb/ft

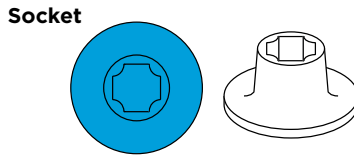

● 763 Aluminum
For mullion 6433 2 3/4" diameter flange
Scale: 3" = 1'-0"

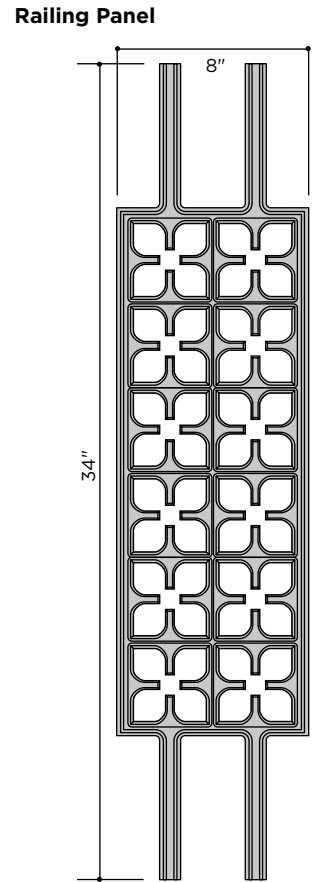

● 1962 Aluminum 4.3 lbs
● 962 Mal. Iron 12.6 lbs

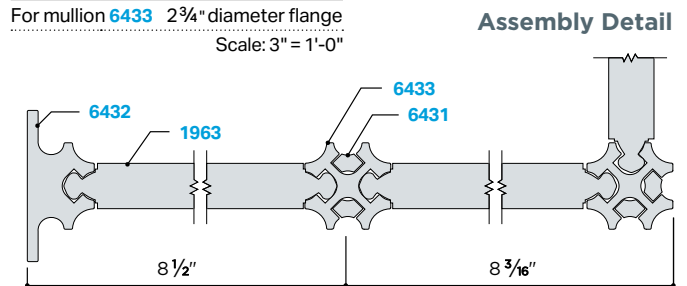

Panels can be joined both vertically and horizontally to form screens and grilles.

All castings are double-faced. Scale: 1½" = 1'-0"

● MALLEABLE IRON

CHATEAU

Railing Panels

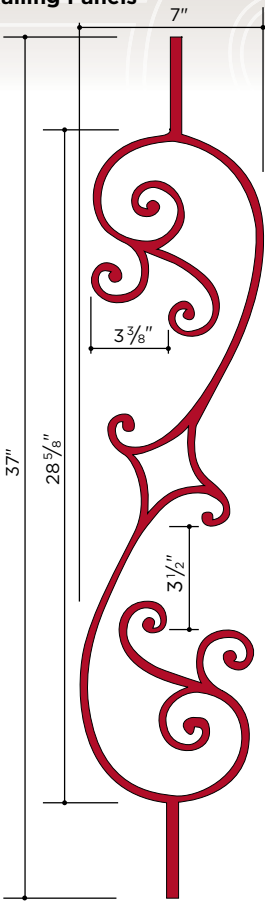

● 537* Malleable Iron 5.5 lbs
Cross Section: Scroll – 1/2" x 5/16"
Ends – 1/2" x 1/2"



● 538* Malleable Iron 7.0 lbs
Cross Section: Scroll – 5/8" x 7/16"
Ends – 1/2" x 1/2"

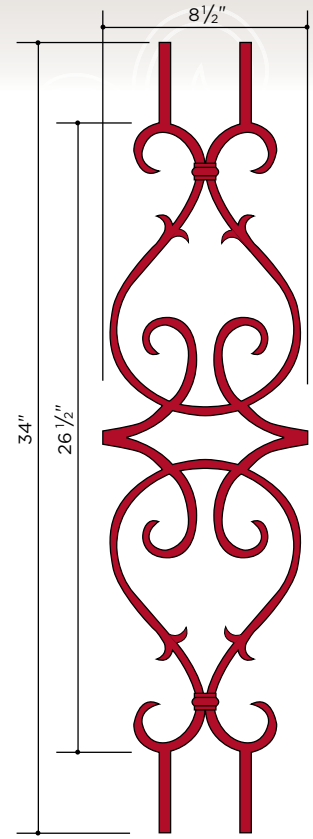

● 539* Malleable Iron 7.8 lbs
Cross Section: Scroll – 5/8" x 7/16"
Ends – 1/2" x 1/2"

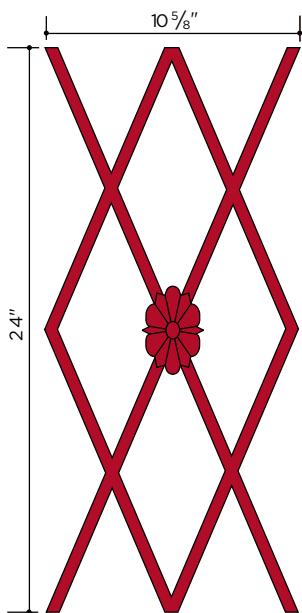

● 540 Malleable Iron 9 lbs
Cross Section: 5/8" x 1/2"

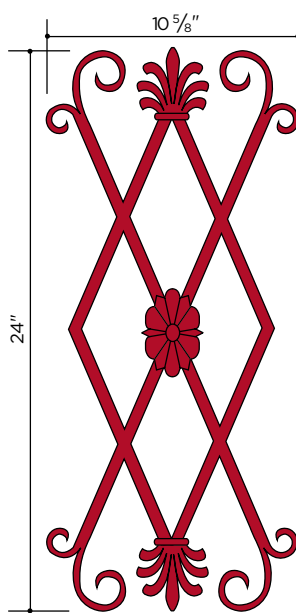

● 541* Malleable Iron 10 lbs
Cross Section: 5/8" x 1/2"



The illustration is intended to be an example of ways Treillage and Traditional Railing components may be combined.

When framed, the open spaces will conform to 4" sphere requirement.

Panels 540 and 541 may be combined both horizontally and vertically and combined with spindles.

● MALLEABLE IRON

All castings are double faced. Scale: 1 1/2" = 1'-0"

BORDEAUX

CHARNWOOD



● **513** 25.2 lbs
Ht: 36" Wd: 36"
Corner Bracket

● **514** 3.4 lbs
Ht: 6 1/2" Lt: 14"
Valance

Furnished in three sections

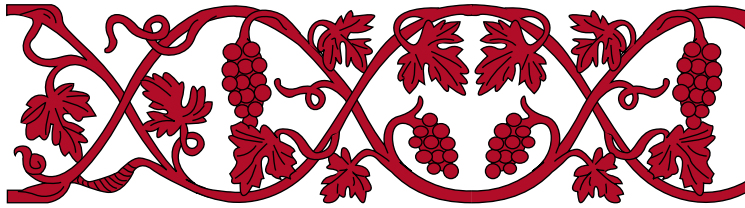

● **511** 11.2 lbs
Ht: 8 1/4" Lt: 31"
Frieze



● **510*** 13.6 lbs
Ht: 29" Wd: 8 1/4"
Railing Panel



● **515B*** 4.9 lbs
Ht: 21" Wd: 11 1/2"
Corner Bracket

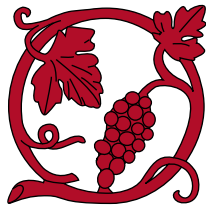

● **512** 4.0 lbs
Ht: 8 1/4" Wd: 8 1/4"
Corner Rosette

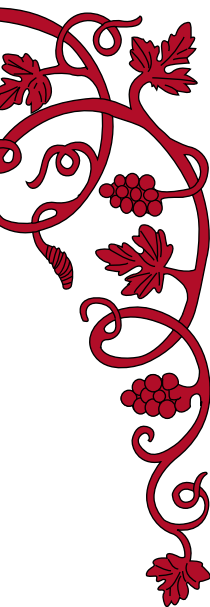

● **515** 8.7 lbs
Ht: 23 1/2" Wd: 25"
Corner Bracket

Furnished in two sections

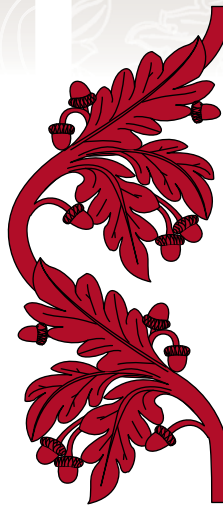

● **555** 9.2 lbs
Ht: 20 3/4" Wd: 9 1/4"
Continuous design

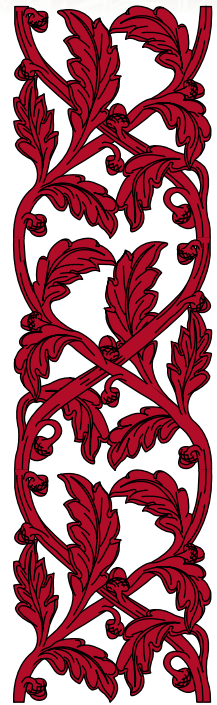

● **548** 12.3 lbs
Ht: 27 3/4" Wd: 8"
Railing Panel

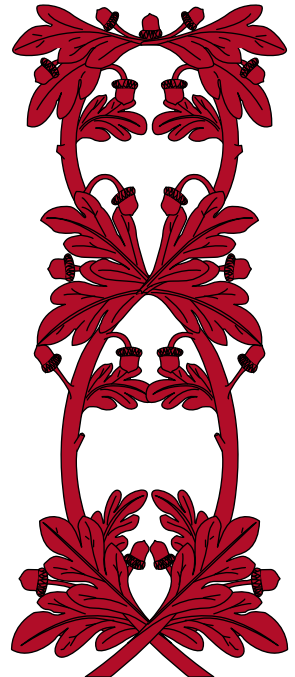

● **558** 16.8 lbs
Ht: 28" Wd: 11 1/2"
Railing Panel

* Color removed to show detail

All castings are double faced. Scale: 1 1/2" = 1'-0"

● MALLEABLE IRON

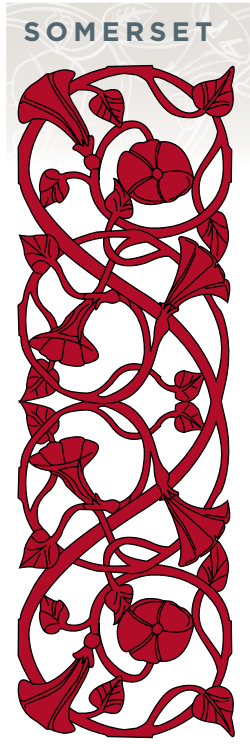

SOMERSET

● 580 13.0 lbs
Ht: 28" Wd: 9"
Railing Panel



● 581* 4.1 lbs
Ht: 9" Wd: 9"
Corner Rosette

*Color removed to show detail

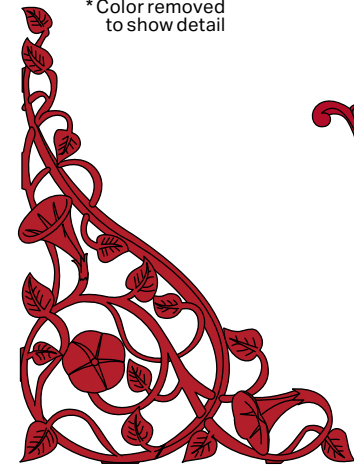

● 582 6.5 lbs
Ht: 14" Wd: 19"
Corner Bracket



REGENCE

● 525 4.2 lbs
Ht: 13 5/8" Wd: 6 7/16"
End Panel

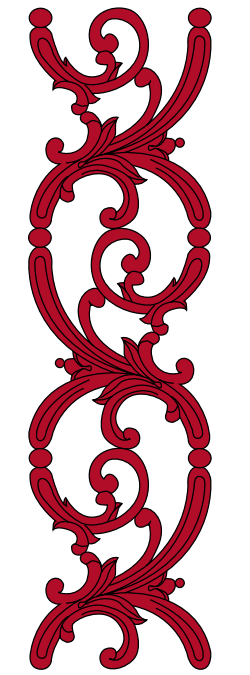

● 576 10.1 lbs
Ht: 29" Wd: 8"
Railing Panel



● 577 8.2 lbs
Ht: 15 1/4" Wd: 18"
Corner Bracket



SIENA

● 523 6.9 lbs
Ht: 20 1/4" Wd: 6 7/16"
Continuous design

● 522 8.4 lbs
Ht: 20 3/8" Wd: 6 7/16"
Continuous design

Repeat or alternate 522 and 523 for continuous runs in columns or friezes.

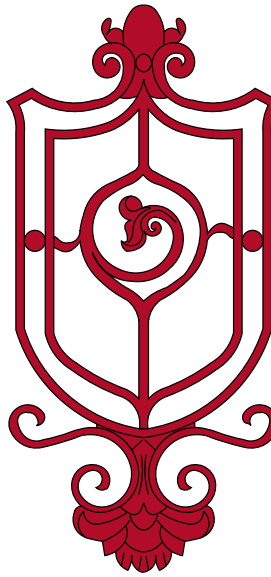

● 521 16.0 lbs
Ht: 24 7/8" Wd: 12"
Railing Panel

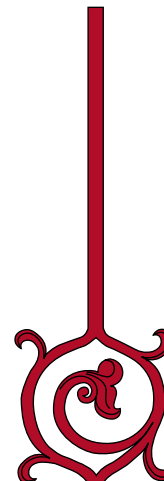

● 532 5.0 lbs
Ht: 36"
Baluster Bar

● 520 10.5 lbs
Ht: 24 7/8" Wd: 6 7/16"
Railing Panel

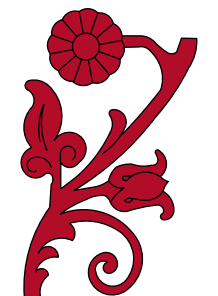

● 524 4.3 lbs
Ht: 12" Wd: 6 7/16"
Starting Panel



● 526 2.6 lbs
Ht: 6 7/16" Wd: 6 7/16"
Corner Rosette

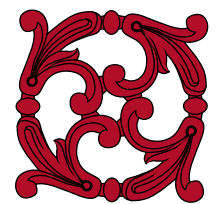

● 578 3.2 lbs
Ht: 8" Wd: 8"
Corner Rosette

● MALLEABLE IRON

All castings are double faced. Scale: 1 1/2" = 1'-0"

DRESDEN

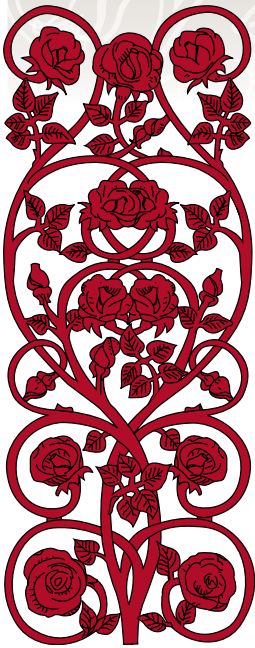

● 571 14.0 lbs
Ht: 28" Wd: 11"
Railing Panel

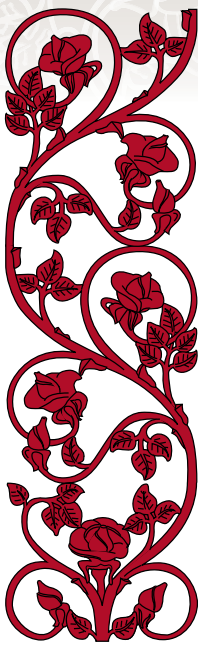

● 568 8.7 lbs
Ht: 28" Wd: 8 1/2"
Railing Panel

Use together with 569



● 569 6.5 lbs
Ht: 21" Wd: 8 1/2"
Continuous design



● 572 5.7 lbs
Ht: 22 1/2" Wd: 7"
Continuous design



● 574 5.0 lbs
Ht: 10 1/4" Wd: 16"
Corner Bracket



● 573 2.3 lbs
Ht: 7" Wd: 7"
Corner Rosette

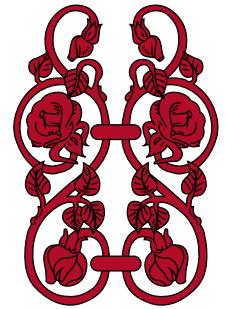

● 570 4.1 lbs
Ht: 12 1/2" Wd: 8 1/2"
Collar

Collar is open on one side to fit over 1/2" square bar

ROCOCO

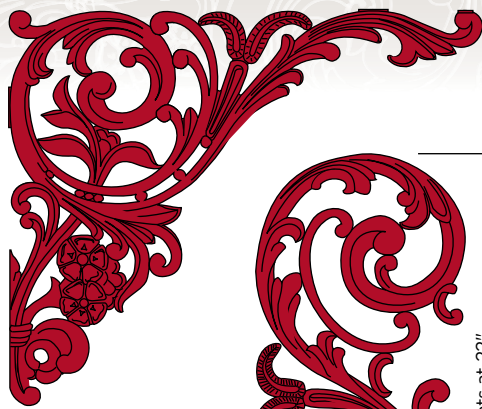

● 588 10.5 lbs
Ht: 16 1/2" Wd: 19 3/4"
Corner Bracket



● 587 10.7 lbs
Ht: 23 1/4" Wd: 8 3/4"
Continuous design

Design repeats at 22"

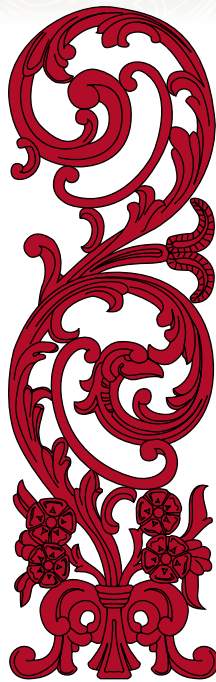

● 586 14.9 lbs
Ht: 28" Wd: 8 3/4"
Railing Panel

CORINTHIAN

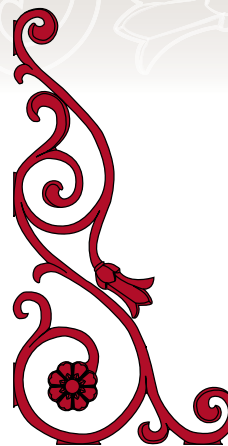

● 552 4.3 lbs
Ht: 10" Wd: 19"
Corner Bracket

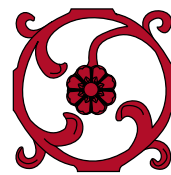

● 551 2.4 lbs
Ht: 7 1/8" Wd: 7 1/8"
Corner Rosette

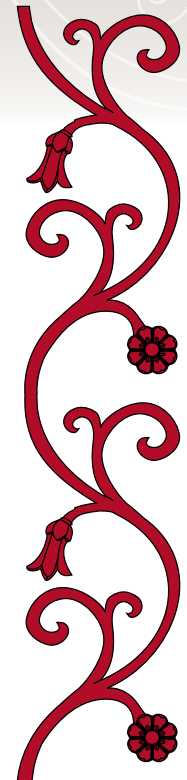

● 550 6.7 lbs
Ht: 34" Wd: 7 1/8"
Continuous design

● MALLEABLE IRON

MILAN



● 519 12.5 lbs
Ht: 32" Wd: 7⁵/₈"
Railing Panel

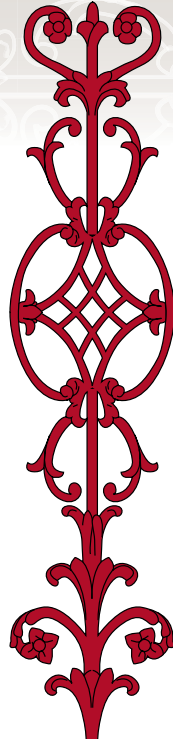

● 518 11.3 lbs
Ht: 35¹/₂" Wd: 7⁵/₈"
Railing Panel

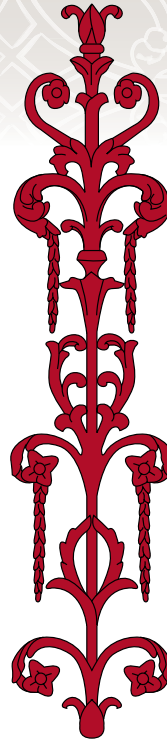

● 517 12.0 lbs
Ht: 34¹/₂" Wd: 7⁵/₈"
Railing Panel

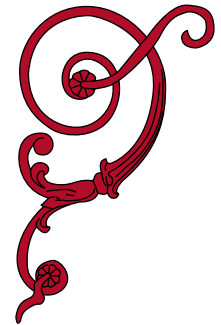

● 516 3.7 lbs
Ht: 8¹/₄" Wd: 13¹/₄"
Corner Bracket

Being of equal width, Milan panels may be stacked vertically.

PRIMAVERA



● 584* 9.9 lbs
Ht: 29" Wd: 6¹/₂"
Railing Panel

* Color removed to show detail

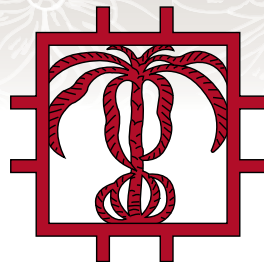

● 591 3.9 lbs
Ht: 10" Wd: 10"
(Without legs: 8" x 8")



● 592 3.4 lbs
Ht: 10" Wd: 10"
(Without legs: 8" x 8")



● 595 3.7 lbs
Ht: 10" Wd: 10"
(Without legs: 8" x 8")

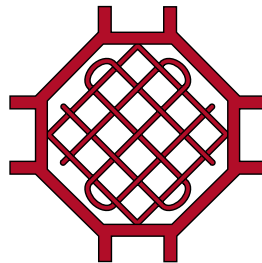

● 593 3.2 lbs
Ht: 10" Wd: 10"
(Without legs: 8" x 8")

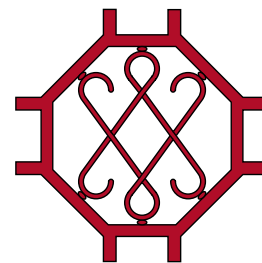

● 594 3.0 lbs
Ht: 10" Wd: 10"
(Without legs: 8" x 8")

All castings are double-faced. Scale: 1 1/2" = 1'-0" except as noted

● MALLEABLE IRON / PRESSED STEEL

PRESSED STEEL MOULDINGS

10' lengths, 100' minimum order

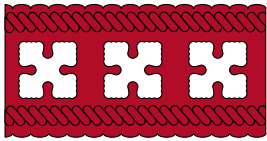

● **2855** Wd: 3 1/4"
Pressed Steel

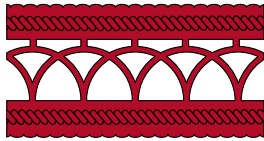

● **2870** Wd: 3 1/4"
Pressed Steel



● **2866** Wd: 3 1/4"
Pressed Steel



● **2859** Wd: 2"
Pressed Steel



● **2861** Wd: 1 5/16"
Pressed Steel

PRESSED STEEL LEAVES**



● **2016** Lt: 4 1/2"



● **2017** Lt: 4 1/2"



● **2023** Lt: 5"



● **2003** Lt: 3 1/2"



● **2023** Lt: 5"



● **2932** Wd: 2 1/2"



| | Length |
|---------------|---------|
| ● 2012 | 6" |
| ● 2014 | 10 1/4" |
| ● 2015 | 11" |



● **2982** Lt: 9 1/4"

PRESSED STEEL ROSETTES**

Malleable Iron

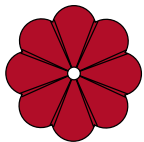

| | OD |
|---------------|--------|
| ● 2515 | 1 1/2" |
| ● 2528 | 2" |
| ● 2538 | 3" |

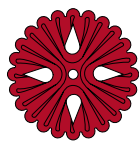

| | OD |
|---------------|--------|
| ● 2611 | 2 3/8" |
| ● 2616 | 3 5/8" |



● **2524** Wd: 1 3/8"

PRESSED STEEL CANDLE PANS AND HUSKS**

Malleable Iron



● **2726**
Ht: 5 1/2" Wd: 2 1/4"



● **2719**
Ht: 5 1/2" Wd: 2 1/4"



● **2640** OD: 3 3/4"



● **2717**
Ht: 3 1/4" Wd: 3 1/4"

** 100 piece packages



Shawnee County Courthouse, Topeka, KS, Senne Company, Topeka, KS (Fabricator), HTK Architects, Topeka, KS (Architect).

222

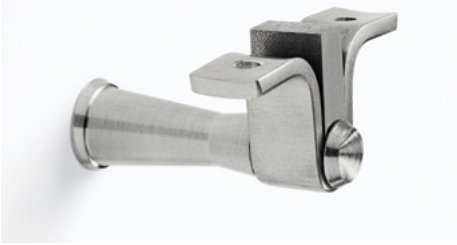

6532

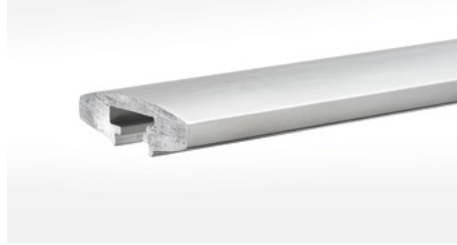

813



The **Carlstadt®** railing system features a full range of components available in aluminum, bronze, nickel-silver, and stainless steel to meet virtually any installation requirement. Posts and handrails may be combined with a variety of post, wall, and fascia brackets to achieve a wide range of design alternatives while meeting code and other regulatory requirements. The Carlstadt® system is designed for non-welded assembly.

- **Aluminum** railing components are made of alloy 6063, except for cast flanges, corner bends, and floor flanges, which are cast from Almag 35. Aluminum extrusions are produced and handled with great care for use in architectural applications and are suitable for most of the hard coat anodic processes. Black anodizing may result in inconsistent matches. Consult your anodizer before specifying.
- **Bronze** components are made of extruded architectural bronze alloy C38500, except for cast cover flanges, corner bends, and terminals, which are cast from alloy C86500.
- **Nickel-Silver** components are extruded of alloy C79800. Nickel-silver is a copper alloy which has the color of stainless steel with golden highlights.
- **Stainless Steel** components are made of type 302/304 (18-8) stainless steel.

The *Americans with Disabilities Act* adopted by Congress in 1992 required circular handrails to be 1¼" minimum and 1½" maximum. However, the *Guidance on the 2010 ADA Standards for Accessible Design - September 2010*, published by the US Department of Justice, has now clarified the intent of the dimensional requirements to be an outside diameter of 1¼" to 2".

Americans With Disabilities Act Accessibility Guidelines (ADAAG) also allows handrails that provide an equivalent gripping surface. ANSI117.1-17 defines this alternative: *equivalent gripping surfaces are permitted provided they have a perimeter dimension of 4" (100mm) minimum and 6¼" (160mm) maximum and provided their largest cross-section dimension is 2¼" (57mm) maximum.*

CARLSTADT® FITTINGS

A complete selection of fittings is available for the Carlstadt® system. Self-aligning wall, post, and mounting brackets are recommended for unusual ramp or stair angles. Handrails may be mounted using flat bars and channels, joined with non-welded corner bends, or closed with end caps. A wide range of cover flanges, fascia flanges, reinforcing bars, and post caps are also available.

CARLSTADT® RAILING

The Carlstadt® railing system provides a flexible range of railing and post components in aluminum, bronze, nickel-silver, and stainless steel to meet almost any installation or code requirement. The Carlstadt® railing system uses Carlstadt® self-aligning handrail brackets. It is the engineer of record's responsibility to evaluate base metal and sleeve compatibility with dissimilar metals.

EXAMPLES OF CARLSTADT® RAILING CONFIGURATIONS

The illustrations are intended to be examples of ways Connectorail®, Carlstadt®, and Traditional Railing components may be combined. See Juliusblum.com for part numbers and details.

SURFACE-MOUNTED

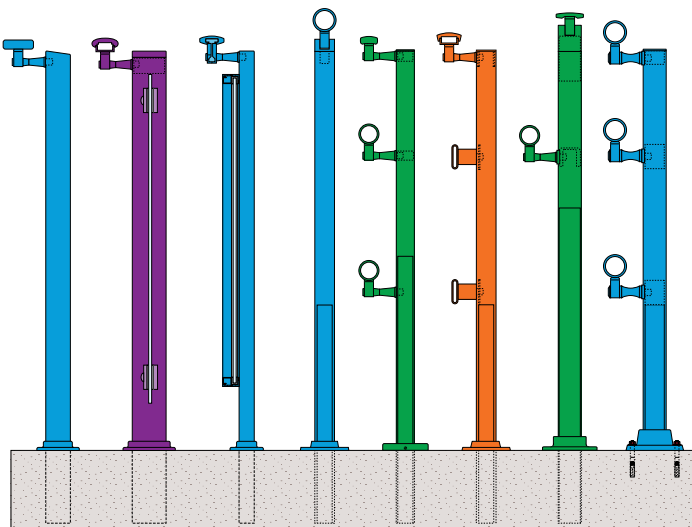

FASCIA-MOUNTED

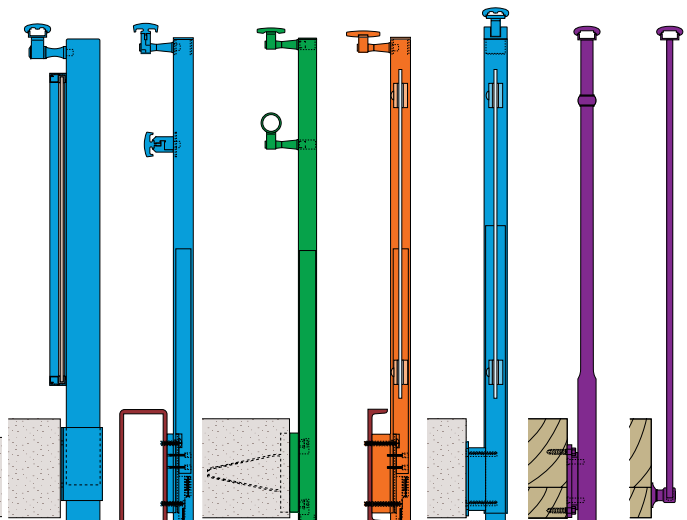

CARLSRAIL® HANDRAIL

20' lengths

The Carlstadt® system for non-welded assembly also features a range of components. Carlsrail® handrail sections may be mounted using channels and then applied directly to the top of a picket or post.

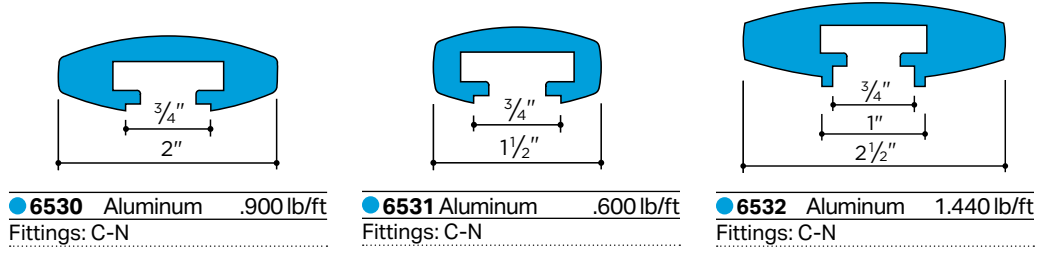

SUPPORT BAR

6063-T6

A slip fit support bar adds both vertical and horizontal stiffness to the handrail mouldings, when required.

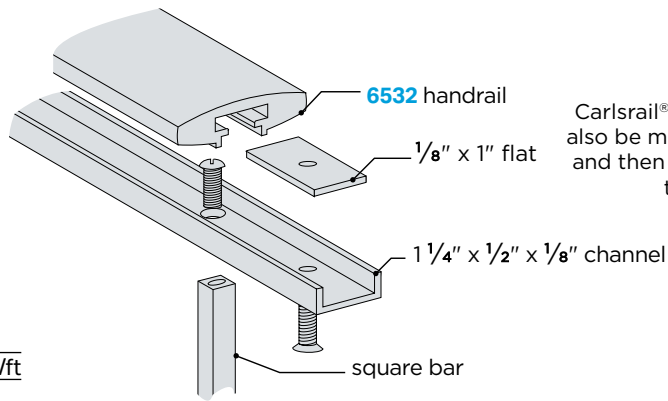
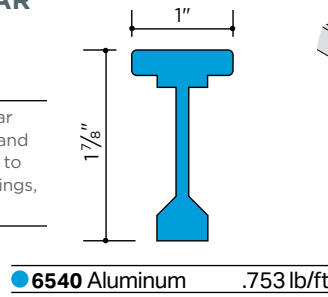

Carlsrail® handrail sections may also be mounted using channels and then applied directly to the top of a picket or post.

Splicing

An internal splice is used to attach corner bends and wall returns, as a connector for continuous runs, and for expansion joints. A set screw tightens and draws components together.

SPLICE INSERT

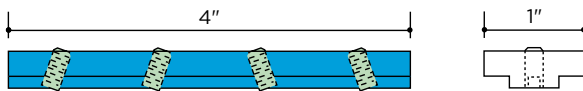

104 Aluminum
Also available in 16' lengths without holes or set screws **104-16**

CORNER SPLICE INSERT

Cast, Almag 35

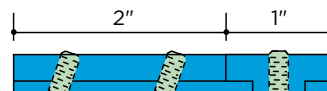

105 Aluminum

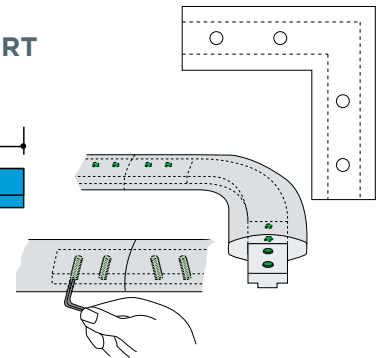

END CAP

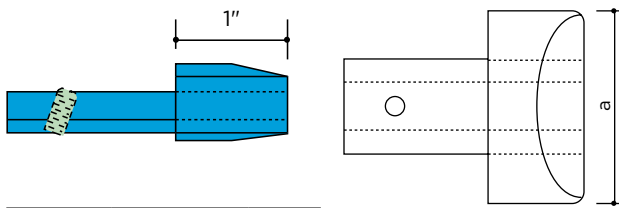

6531N Aluminum a 1 1/2"
6530N Aluminum a 2"
6532N Aluminum a 2 1/2"

CORNER BEND

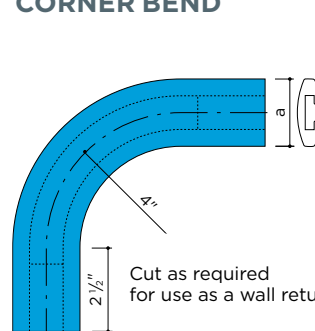

6531C Aluminum a 1 1/2"
6530C Aluminum a 2"
6532C Aluminum a 2 1/2"

● ALUMINUM ● BRONZE ● NICKEL-SILVER ● STAINLESS ● PVC

CARLSRAIL® BRACKET ASSEMBLY

The Carlstadt® bracket assembly features a two-part clamp that, upon slipping together, simultaneously engages the bracket arm and the handrail without requiring drilling or tapping.

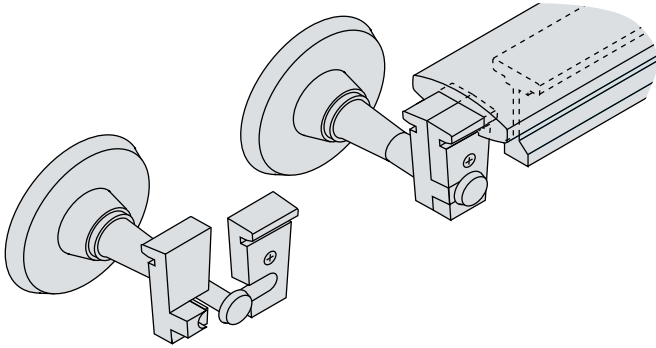

CARLSRAIL® SELF-ALIGNING WALL BRACKETS

Satin Finish

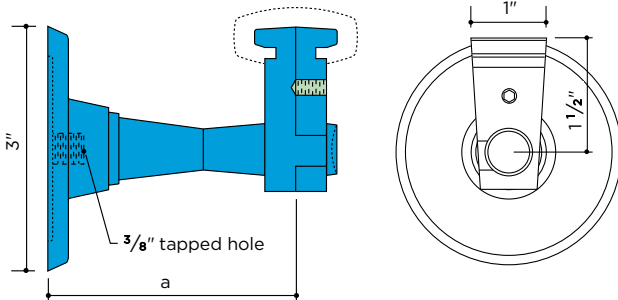

| For use with Carlsrail® handrail moulding | | a |
|-------------------------------------------|----------|--------|
| ● 173 | Aluminum | 3" |
| ● 174 | Aluminum | 3 1/2" |
| ● 175 | Aluminum | 2 1/4" |

CARLSRAIL® SELF-ALIGNING POST BRACKETS

Satin Finish

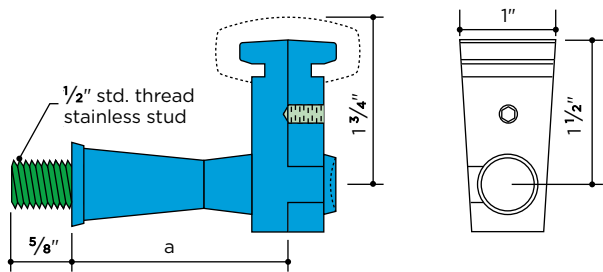

| For use with Carlsrail® handrail moulding | | a |
|-------------------------------------------|----------|--------|
| ● 171 | Aluminum | 2 1/4" |
| ● 172 | Aluminum | 2 3/4" |

CARLSRAIL® WALL & POST BRACKET EXTENSIONS

Satin Finish

For Post Brackets

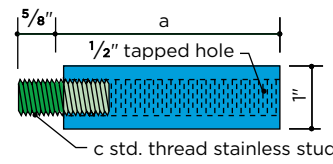

| | a | c |
|--------|-----------------|------|
| ● 462* | Aluminum 1 3/4" | 1/2" |
| ● 463* | Aluminum 3" | 1/2" |

For Wall Brackets

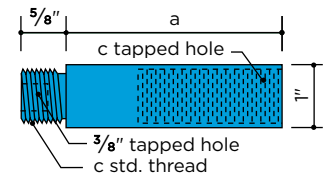

| | a | c |
|-------|-----------------|------|
| ● 464 | Aluminum 1 3/4" | 3/4" |
| ● 465 | Aluminum 3" | 3/4" |

Extensions may be cut to length to suit individual conditions. Trim wall bracket extensions to no shorter than 1 5/8". Designers should note that extending a bracket increases stress at its base and reduces allowable load.

PANEL CLIPS

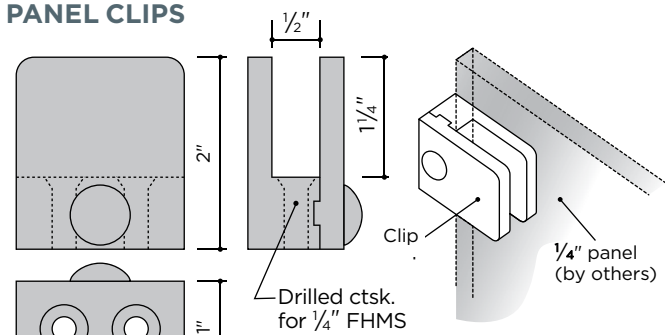

| | |
|-------|---------------|
| ● 113 | Aluminum |
| ● 813 | Bronze |
| ● 413 | Nickel-Silver |
| ● 213 | Stainless |

GLAZING MEMBERS

Aluminum glass stop/snap-in and flexible PVC glazing channel serve to mount panels of 1/4" glass, plastic, wire mesh, or other material.

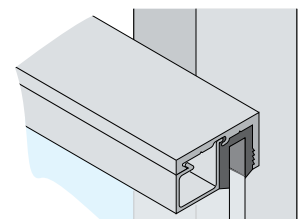

Glass Stop 20' lengths

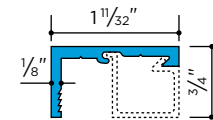

| | | |
|--------|-------------------|------------|
| ● 8106 | Aluminum | .276 lb/ft |
| ● 8206 | Aluminum Anodized | .276 lb/ft |

Snap-in 20' lengths

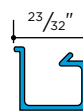

| | | |
|--------|-------------------|------------|
| ● 8107 | Aluminum | .138 lb/ft |
| ● 8207 | Aluminum Anodized | .138 lb/ft |

Flexible PVC Channel 50' coils

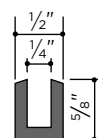

| | | |
|--------|--------------|--------------|
| ● 8708 | Flexible PVC | 90 durometer |
|--------|--------------|--------------|

PRECUT SOLID ALUMINUM POSTS

Aluminum 6063-T52, Mill Finish, 48" lengths
Upper end has been trimmed as shown—no post cap is required.
Lower end may be cut to achieve required post height. Drill and tap to receive Carlstadt® post brackets.

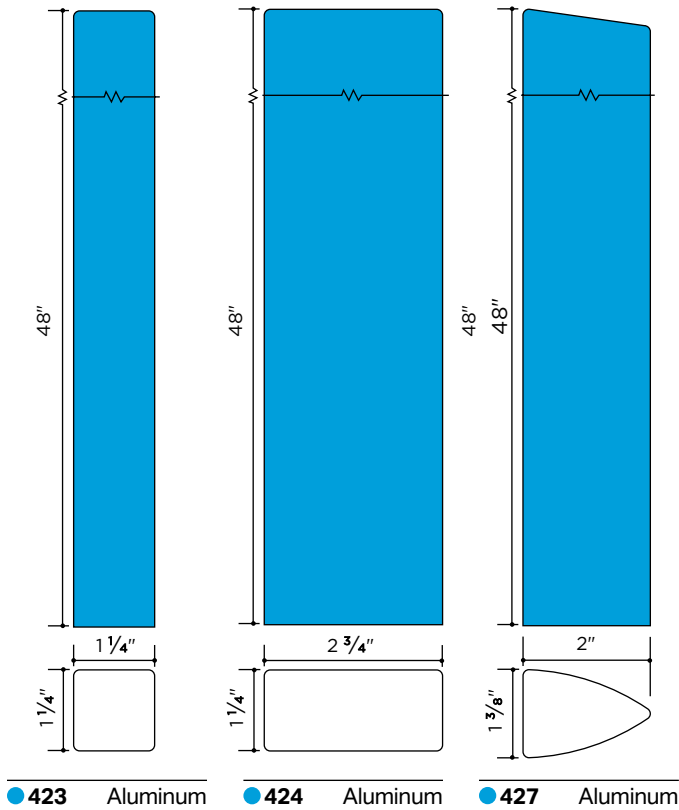
**BAR STOCK FOR RAILING POSTS**

Aluminum 6063-T52, 20' lengths. Mill Finish.

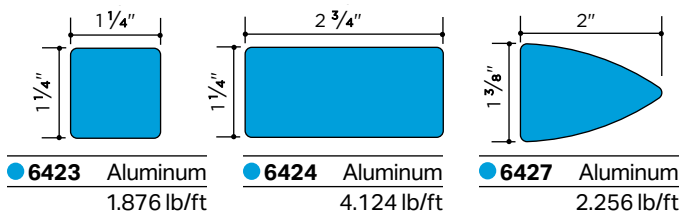
**Installation Details**

Post is set in metal sleeve in concrete and grouted. Embed post to a depth of 4" to 6" in slab. Allow for a 1" grout pad beneath post. Sleeve should provide ample clearance around post for grouting and to allow for adjustment to field variations. For outdoor installations, weep holes should be drilled in the posts to prevent water from collecting below ground level. A cover flange conceals the floor opening.

COVER FLANGES

Satin Finish

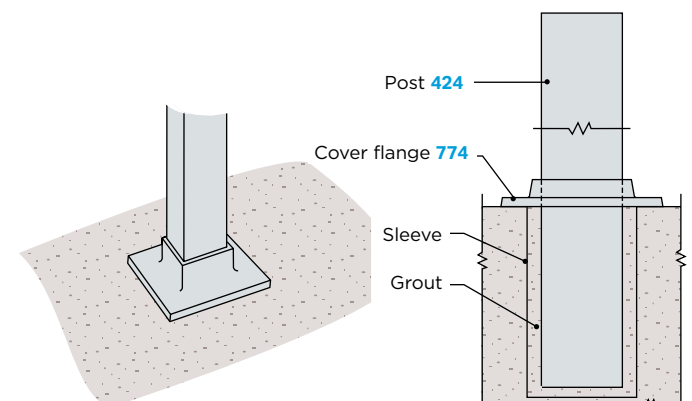
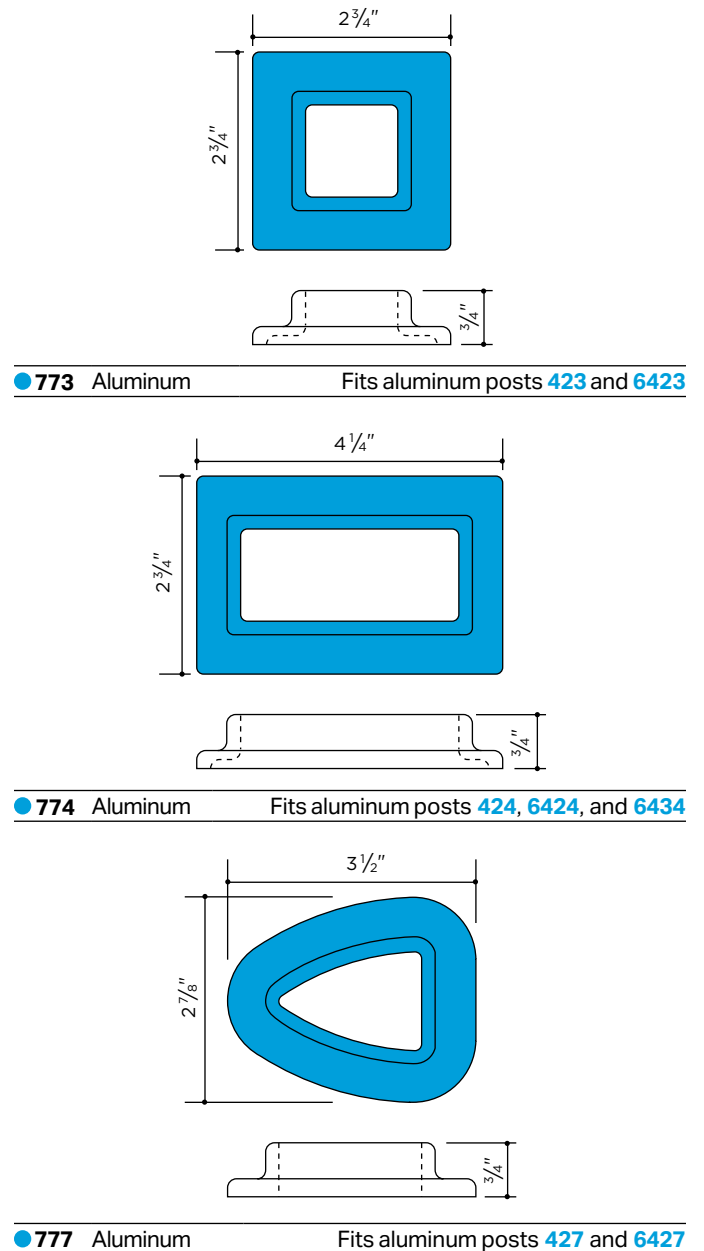

● ALUMINUM

FASCIA FLANGES

Sleeve-type fascia flanges are provided with two clearances for mounting on solid or channel fascias and stringers. The post slips into the pocket of the fascia flange and is anchored with concealed set screws. The bottom extension of each fascia flange matches the profile of the post and is trimmed to match its top.

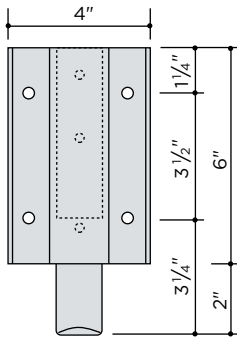
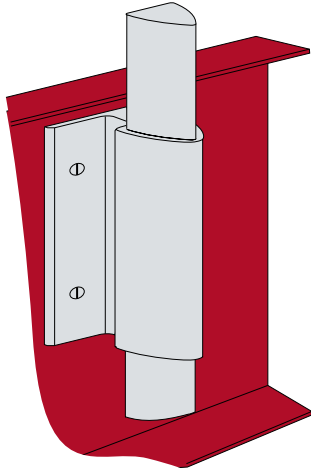

Elevation of **425** and **426**

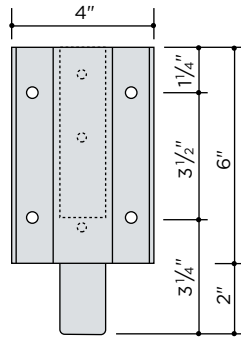

Elevation of **408**, **421**, and **422**

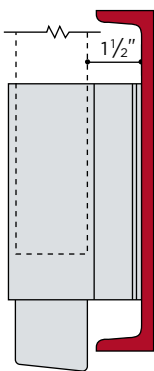

Fascia flange **426** used with channel stringer.

Fascia flange **422** is similar.

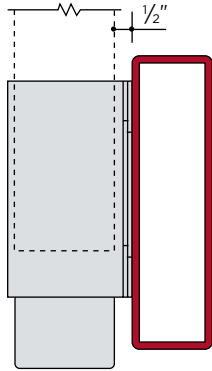

Fascia flange **408** used with box stringer.

Fascia flanges **421** and **425** are similar.

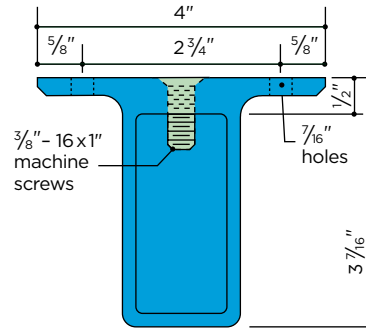

● **408** Aluminum
Fits aluminum posts
424, **6424**, **6434**

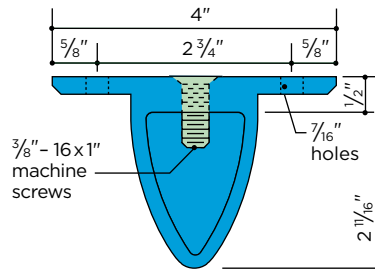

● **425** Aluminum
Fits aluminum posts
427 and **6427**

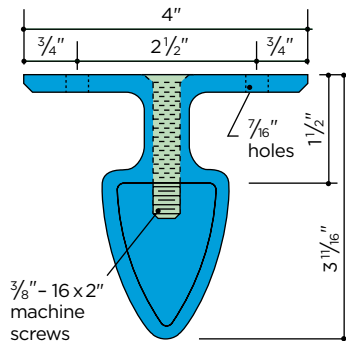

● **426** Aluminum
Fits aluminum posts
427 and **6427**

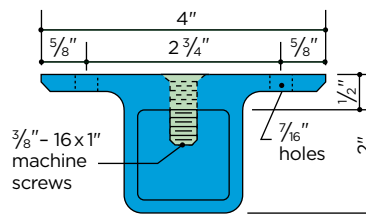

● **421** Aluminum
Fits aluminum posts
423 and **6423**

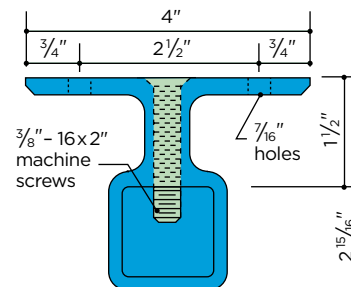

● **422** Aluminum
Fits aluminum posts
423 and **6423**

PRECUT POST

For fascia mounting,
51" lengths, Mill Finish

Aluminum 6063-T6
Bronze C38500

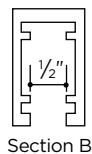
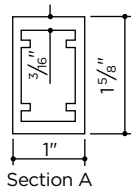
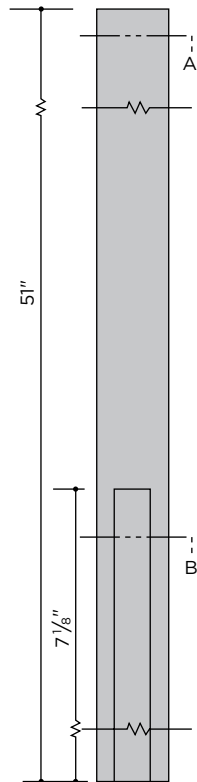

- **430*** Aluminum
- **830*** Bronze

* Cut and machined for use with fascia brackets

430



REINFORCING BARS

Aluminum 6063-T6

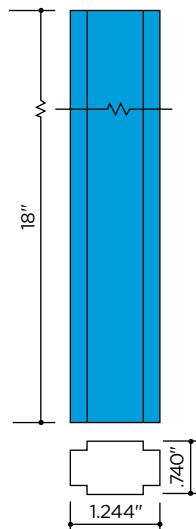

- **436E** Aluminum
- Fits posts **430** or **830**

TUBING FOR FLOOR-MOUNTED POSTS

20' lengths, Mill Finish

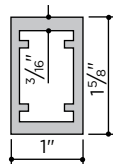

- | | lb/ft |
|------------------------|-------|
| ● 6430 Aluminum | .899 |
| ● 4830 Bronze | 2.950 |

Aluminum items are suitable for anodizing, including most of the hardcoat color finishes. Properties of sections for handrail posts are listed on page 123. Refer to pages 122-127 for detailed information on the structural design of handrail installations.

COVER FLANGES

Satin Finish

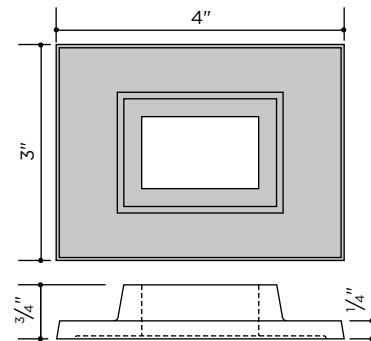

- **435** Aluminum
 - **835** Bronze
- Fits aluminum post **430** or **6430**
Fits bronze post **830** or **4830**

POST BRACKET ANCHOR PLUGS

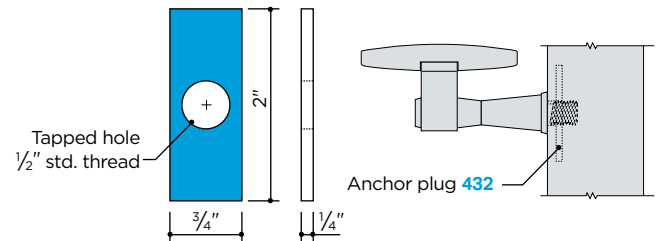

- **432** Aluminum
- Fits posts **430** and **830**

Floor Mounted Post Detail

Reinforcing bar is placed within mating hollow post. Post is set in metal sleeve in concrete and grouted. Embed post to a depth of 4" to 6" in slab. Allow for a 1" grout pad beneath post. Sleeve should provide ample clearance around post for grouting and to allow for adjustment to field variations. For outdoor installations, weep holes should be drilled in the posts to prevent water from collecting below ground level. A cover flange conceals the floor opening.

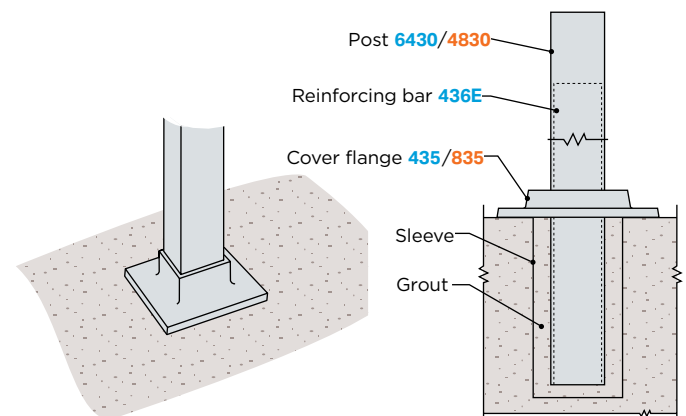

● ALUMINUM ● BRONZE ● STAINLESS

FASCIA BRACKETS

Mill Finish

Fascia brackets are available for concealed fastening of hollow posts of aluminum, bronze, and stainless steel—both for solid and channel fascias. The fastening mechanism provides for vertical field adjustment.

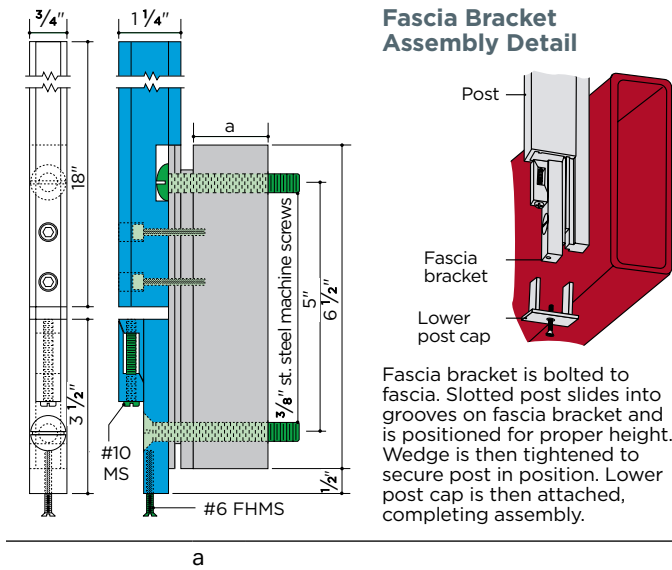

- 428** Aluminum 1/2" For box stringers, fits aluminum post **430**
429 Aluminum 1 1/2" For channel stringers, fits aluminum post **430**
838 Bronze 1/2" For box stringers, fits bronze post **830**
839 Bronze 1 1/2" For channel stringers, fits bronze post **830**

CENTER POST BRACKETS

Satin Finish

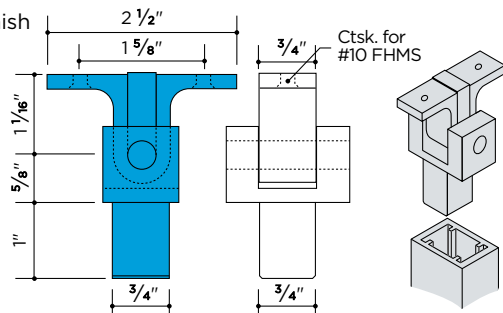

- 161** Aluminum Curved for pipe, fits aluminum posts **430** and **6430**
162 Aluminum Flat for moulding, fits aluminum posts **430** and **6430**

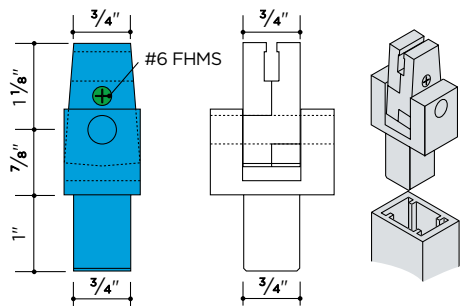

- 152** Alum. For Carlstadt® T-handrail, fits aluminum posts **430** and **6430**

Center post brackets permit handrail to be centered directly over post, while allowing the bracket to tilt to conform to stair incline. Bracket is secured to post with pin or screw.

POST CAPS

Satin Finish

Caps for hollow Carlstadt® posts have a flange extending inside to receive and support the thread of the bracket arm.

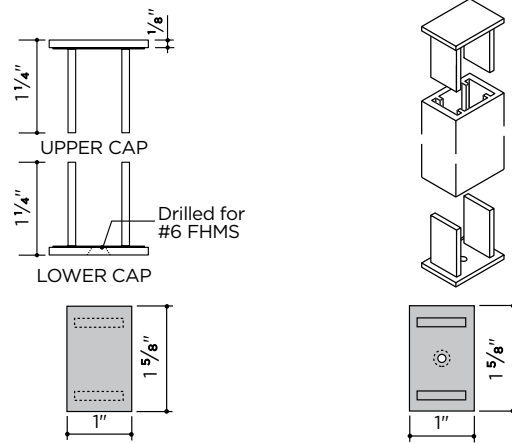

- Upper Cap**
431 Aluminum
831 Bronze
- Lower Cap**
433 Aluminum
833 Bronze
- Fits aluminum posts **430** and **6430** and bronze posts **830** and **4830**

POST ANCHOR FOR CAST STEPS

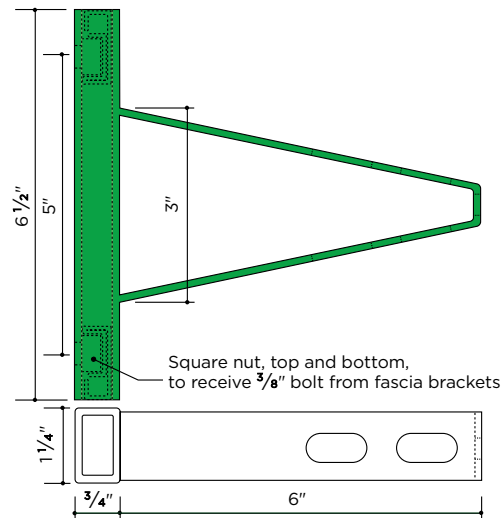

- 227** Stainless For use with aluminum and bronze railings

Post anchor **227** can be used with fascia brackets **428**, **429**, **838**, **839**, or to mount Carlstadt® aluminum or bronze posts. Cast post anchor into concrete with minimum slab thickness of 3" and minimum compressive strength of 3500 psi. Maximum recommended post spacing for 3" slabs is 30"; for slabs 4" thick and thicker, recommended maximum post spacing is 48".

Post Anchor Installation

Anchor is embedded in slab with anchor centered vertically in slab thickness. Front face of anchor should be flush with edge of slab. Square nuts move freely in pockets, and receive 3/8" mounting bolts of Carlstadt® fascia brackets. Wide slots provide for lateral adjustment and vertical alignment.

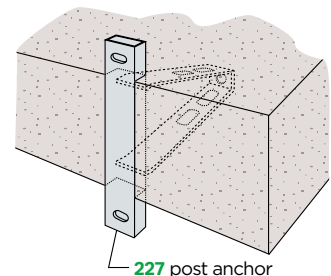

CARLSTADT®
RAILINGS

PRECUT POST

For fascia mounting,
51" lengths, Mill Finish

Aluminum 6063-T6

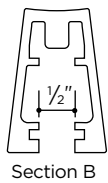
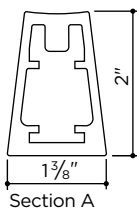
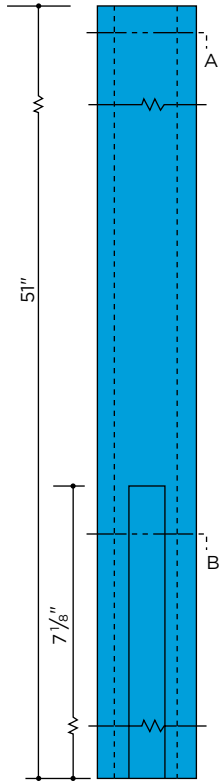

● **458*** Aluminum

* Cut and machined for use with fascia brackets

458

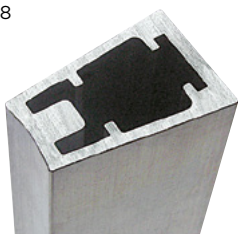

REINFORCING BARS

Aluminum 6063-T6

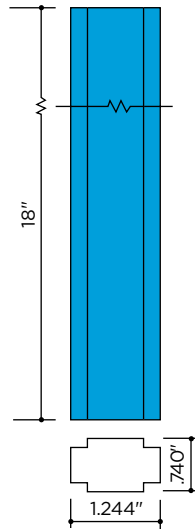

● **436E** Aluminum

Fits aluminum post **458**

TUBING FOR FLOOR-MOUNTED POSTS

20' lengths, Mill Finish

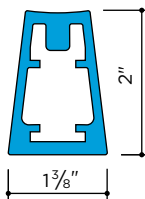

● **645E** Aluminum 1.326 lb/ft

Aluminum items are suitable for anodizing, including most of the hardcoat color finishes. Properties of sections for handrail posts are listed on page 123. Refer to pages 122-127 for detailed information on the structural design of handrail installations.

COVER FLANGES

Satin Finish

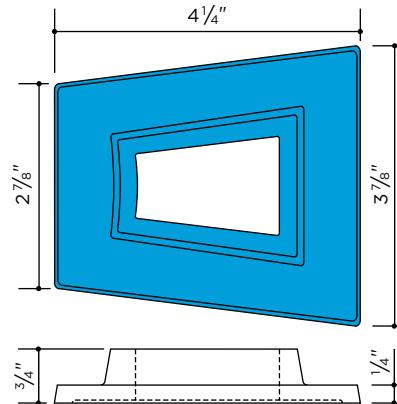

● **495** Aluminum

Fits aluminum post **458** or **645E**

POST BRACKET ANCHOR PLUGS

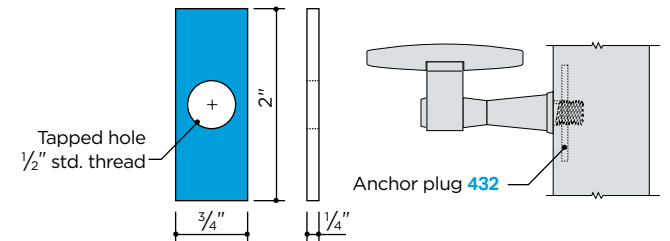

● **432** Aluminum

Fits aluminum post **458**

Floor Mounted Post Detail

Reinforcing bar is placed within mating hollow post. Post is set in metal sleeve in concrete and grouted. Embed post to a depth of 4" to 6" in slab. Allow for a 1" grout pad beneath post. Sleeve should provide ample clearance around post for grouting and to allow for adjustment to field variations. For outdoor installations, weep holes should be drilled in the posts to prevent water from collecting below ground level. A cover flange conceals the floor opening.

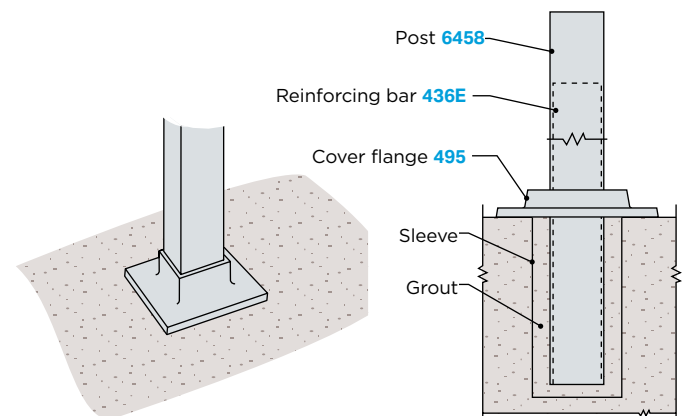

● ALUMINUM ● STAINLESS

FASCIA BRACKETS

Mill Finish

Fascia brackets are available for concealed fastening of hollow posts of aluminum, bronze, and stainless steel—both for solid and channel fascias. The fastening mechanism provides for vertical field adjustment.

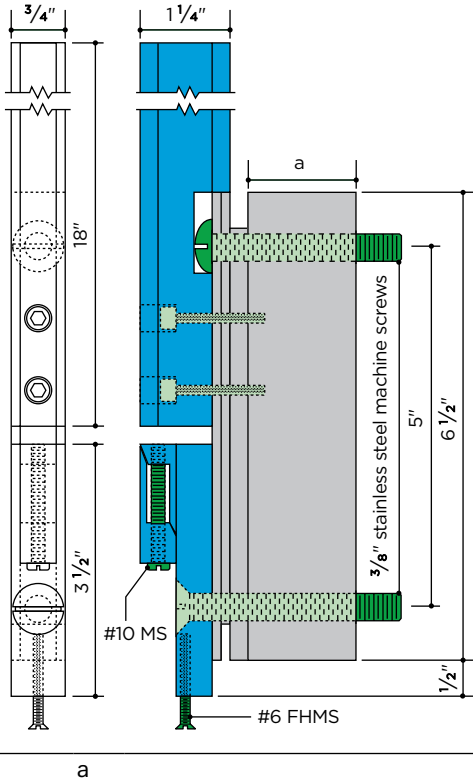

- **428** Aluminum 1/2" For box stringers, fits aluminum post **458**
- **429** Aluminum 1 1/2" For channel stringers, fits aluminum post **458**

Fascia Bracket Assembly Detail

Fascia bracket is bolted to fascia. Slotted post slides into grooves on fascia bracket and is positioned for proper height. Wedge is then tightened to secure post in position. Lower post cap is then attached, completing assembly.

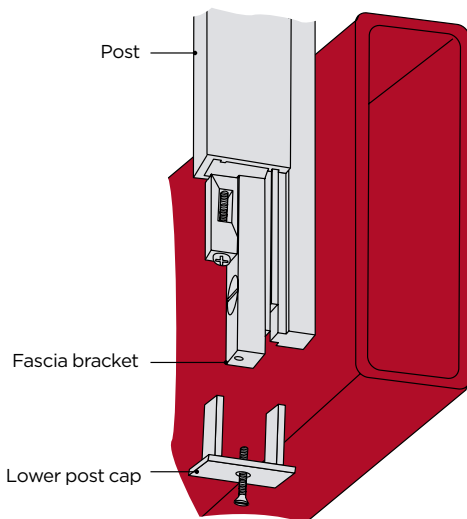

POST CAPS

Satin Finish

Caps for hollow Carlstadt® posts have a flange extending inside to receive and support the thread of the bracket arm.

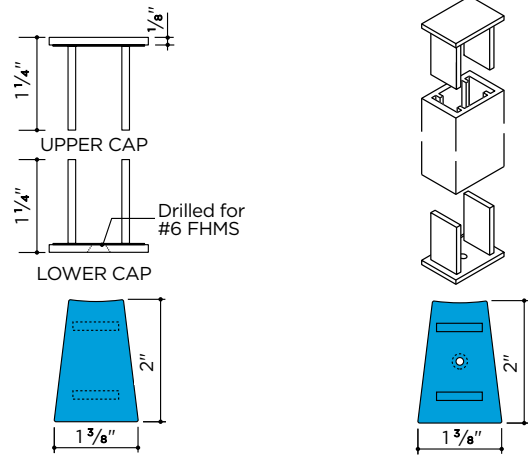

- Upper Cap**
● **468** Aluminum
Fits aluminum posts **458** and **6458**
- Lower Cap**
● **469** Aluminum
Fits aluminum posts **458** and **6458**

POST ANCHOR FOR CAST STEPS

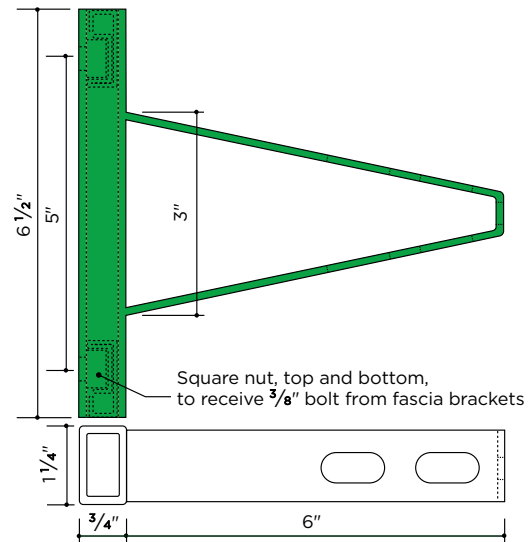

- **227** Stainless For use with aluminum and bronze railings

Post anchor **227** can be used with fascia brackets **428** and **429** to mount Carlstadt® aluminum or bronze posts. Cast post anchor into concrete with minimum slab thickness of 3" and minimum compressive strength of 3500 psi. Maximum recommended post spacing for 3" slabs is 30"; for slabs 4" thick and thicker, recommended maximum post spacing is 48".

Post Anchor Installation

Anchor is embedded in slab with anchor centered vertically in slab thickness. Front face of anchor should be flush with edge of slab. Square nuts move freely in pockets, receive 3/8" mounting bolts of Carlstadt® fascia brackets. Wide slots provide for lateral adjustment and vertical alignment.

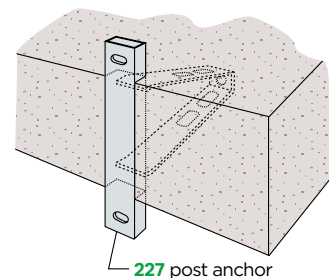

PRECUT POST

For fascia mounting,
51" lengths, Mill Finish

Aluminum 6063-T6

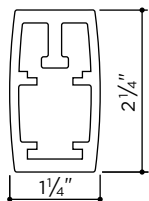
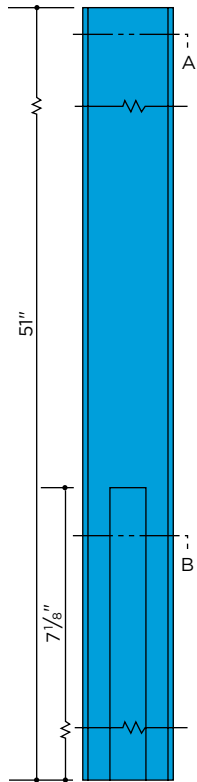

Section A

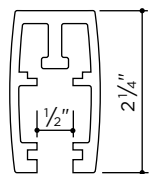

Section B

● **459*** Aluminum

* Cut and machined for use with fascia brackets

459

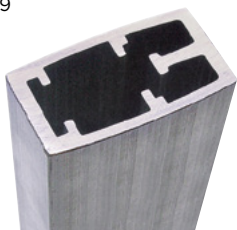

REINFORCING BARS

Aluminum 6063-T6

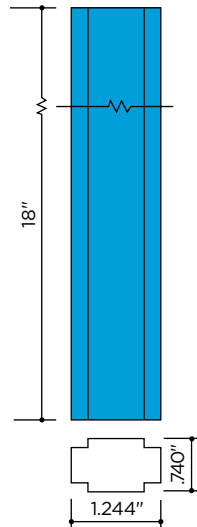

● **436E** Aluminum

Fits aluminum post **459**

TUBING FOR FLOOR-MOUNTED POSTS

20' lengths, Mill Finish

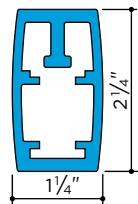

● **6459** Aluminum 1.240 lb/ft

Aluminum items are suitable for anodizing, including most of the hardcoat color finishes. Properties of sections for handrail posts are listed on page 123. Refer to pages 122-127 for detailed information on the structural design of handrail installations.

COVER FLANGES

Satin Finish

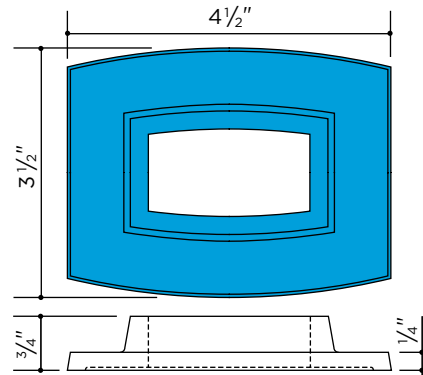

● **496** Aluminum

Fits aluminum post **459** or **6459**

POST BRACKET ANCHOR PLUGS

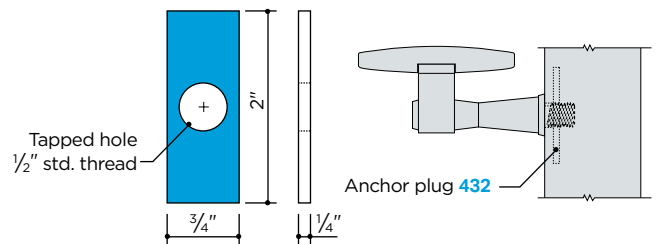

● **432** Aluminum

Fits aluminum post **459**

Floor Mounted Post Detail

Reinforcing bar is placed within mating hollow post. Post is set in metal sleeve in concrete and grouted. Embed post to a depth of 4" to 6" in slab. Allow for a 1" grout pad beneath post. Sleeve should provide ample clearance around post for grouting and to allow for adjustment to field variations. For outdoor installations, weep holes should be drilled in the posts to prevent water from collecting below ground level. A cover flange conceals the floor opening.

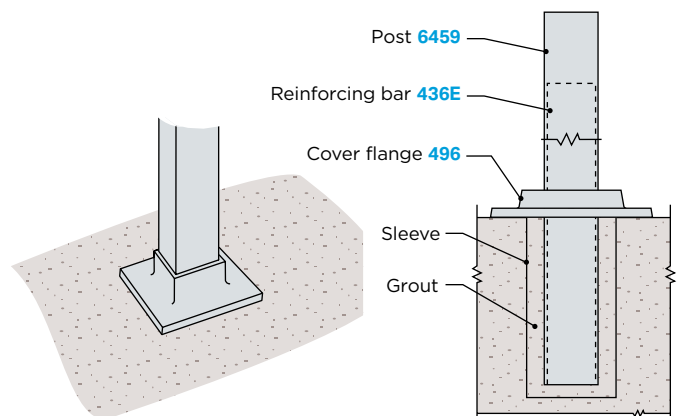

● ALUMINUM ● STAINLESS

FASCIA BRACKETS

Mill Finish

Fascia brackets are available for concealed fastening of hollow posts of aluminum, bronze, and stainless steel—both for solid and channel fascias. The fastening mechanism provides for vertical field adjustment.

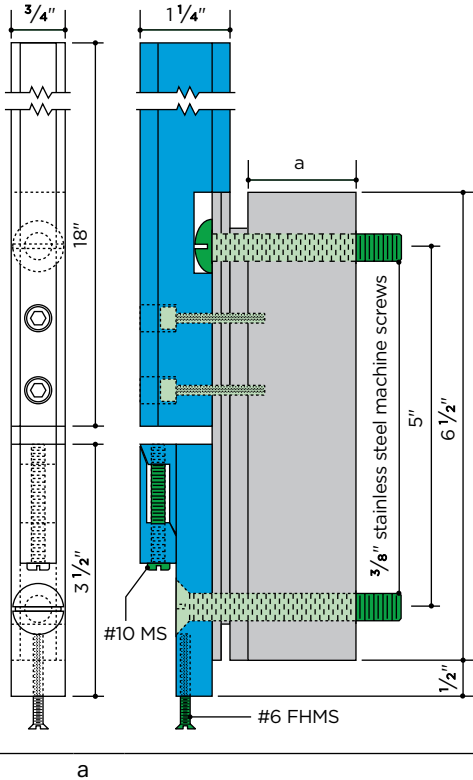

- 428 Aluminum 1/2" For box stringers, fits aluminum post 458
- 429 Aluminum 1 1/2" For channel stringers, fits aluminum post 458

Fascia Bracket Assembly Detail

Fascia bracket is bolted to fascia. Slotted post slides into grooves on fascia bracket and is positioned for proper height. Wedge is then tightened to secure post in position. Lower post cap is then attached, completing assembly.

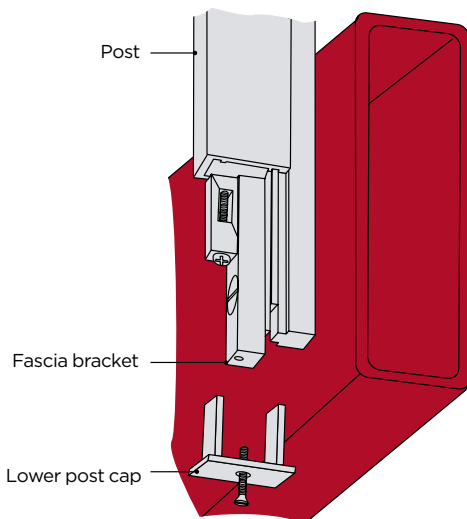

POST CAPS

Satin Finish

Caps for hollow Carlstadt® posts have a flange extending inside to receive and support the thread of the bracket arm.

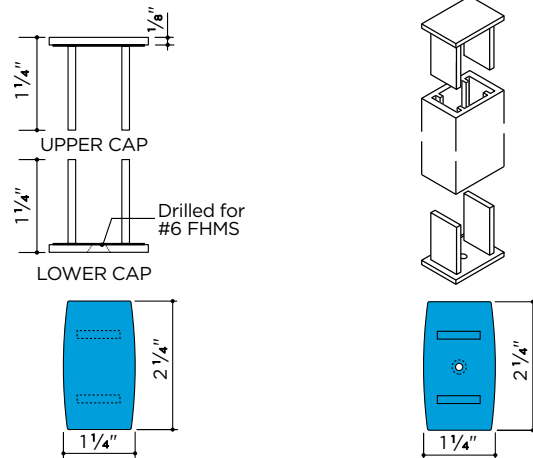

- Upper Cap**
● 451 Aluminum
Fits aluminum posts 459 and 6459
- Lower Cap**
● 453 Aluminum
Fits aluminum posts 459 and 6459

POST ANCHOR FOR CAST STEPS

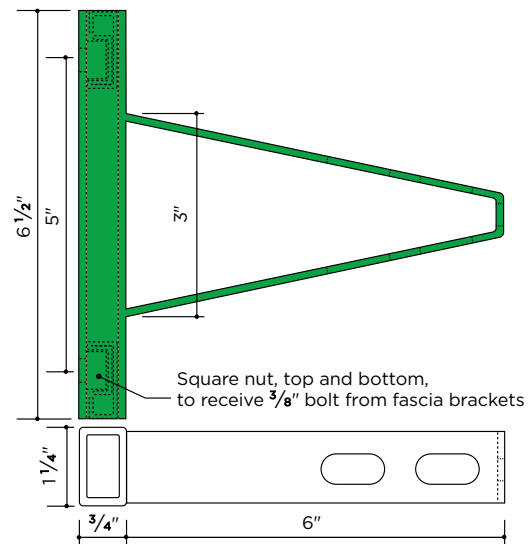

- 227 Stainless For use with aluminum and bronze railings

Post anchor 227 can be used with fascia brackets 428 and 429 to mount Carlstadt® aluminum or bronze posts. Cast post anchor into concrete with minimum slab thickness of 3" and minimum compressive strength of 3500 psi. Maximum recommended post spacing for 3" slabs is 30"; for slabs 4" thick and thicker, recommended maximum post spacing is 48".

Post Anchor Installation

Anchor is embedded in slab with anchor centered vertically in slab thickness. Front face of anchor should be flush with edge of slab. Square nuts move freely in pockets, receive 3/8" mounting bolts of Carlstadt® fascia brackets. Wide slots provide for lateral adjustment and vertical alignment.

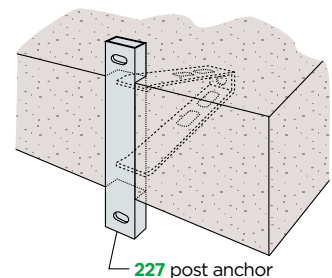

● ALUMINUM ● STAINLESS

PRECUT POST

For fascia mounting,
51" lengths, 2B Mill Finish

Stainless Type 304

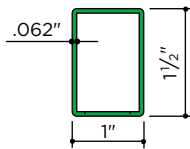
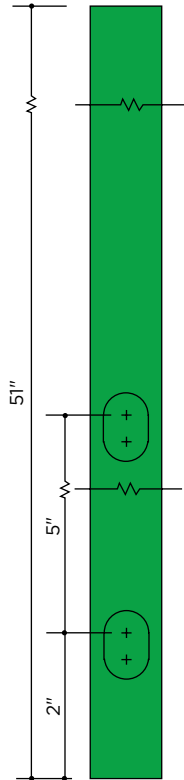

● 230* Stainless

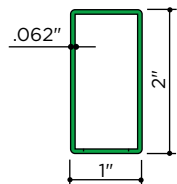

● 280* Stainless

* Cut and punched for fascia block

Properties of sections for handrail posts are listed on page 123. Refer to pages 122-127 for detailed information on the structural design of handrail installations.

REINFORCING BARS

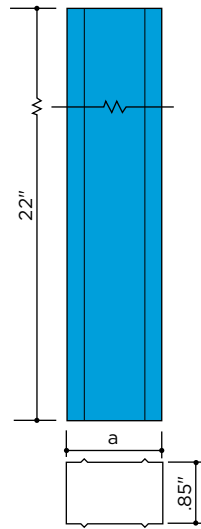

| | |
|-------------------------|-------|
| ● 294 Aluminum | 1.34" |
| Fits stainless post 230 | |
| ● 295 Aluminum | 1.84" |
| Fits stainless post 280 | |

TUBING FOR FLOOR-MOUNTED POSTS

20' lengths, 2B Mill Finish

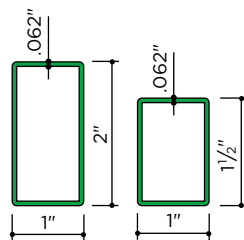

● Stainless Tubing

COVER FLANGES

Satin Finish

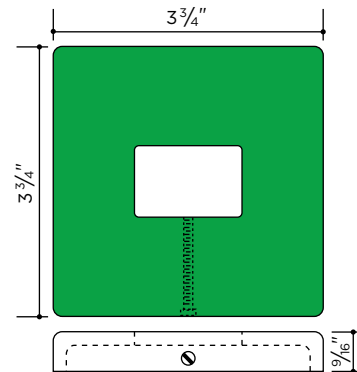

| | |
|-----------------|-----------------------------------|
| ● 237 Stainless | Fits stainless post 230 or tubing |
| ● 285 Stainless | Fits stainless post 280 or tubing |

POST BRACKET ANCHOR PLUGS

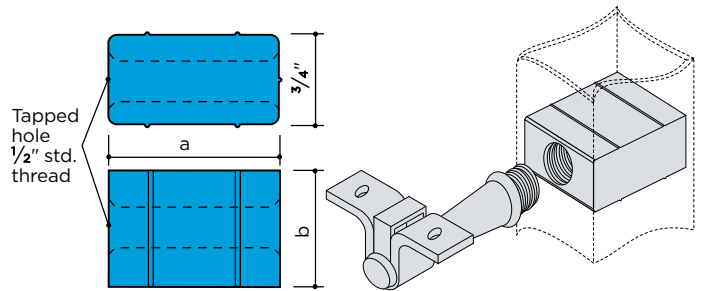

| | a | b | |
|----------------|-------|--------|------------------------------|
| ● 238 Aluminum | 1.34" | 1 1/8" | Fits with stainless post 230 |
| ● 279 Aluminum | 1.84" | 1 1/4" | Fits with stainless post 280 |

Floor Mounted Post Detail

Reinforcing bar is placed within mating hollow post. Post is set in metal sleeve in concrete and grouted. Embed post to a depth of 4" to 6" in slab. Allow for a 1" grout pad beneath post. Sleeve should provide ample clearance around post for grouting and to allow for adjustment to field variations. For outdoor installations, weep holes should be drilled in the posts to prevent water from collecting below ground level. A cover flange conceals the floor opening.

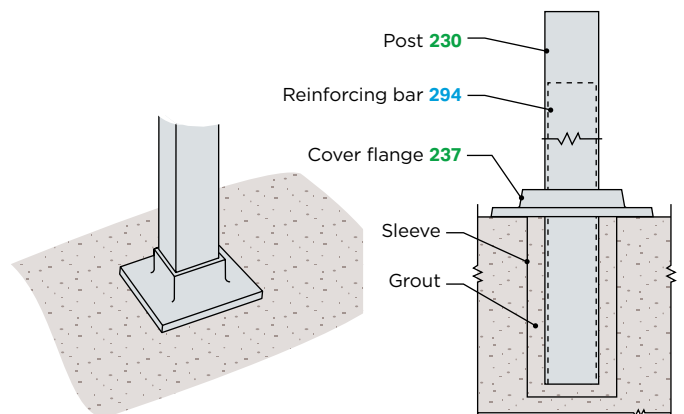

● ALUMINUM ● STAINLESS

ANCHOR BAR WITH LOWER POST CAP

Mill Finish

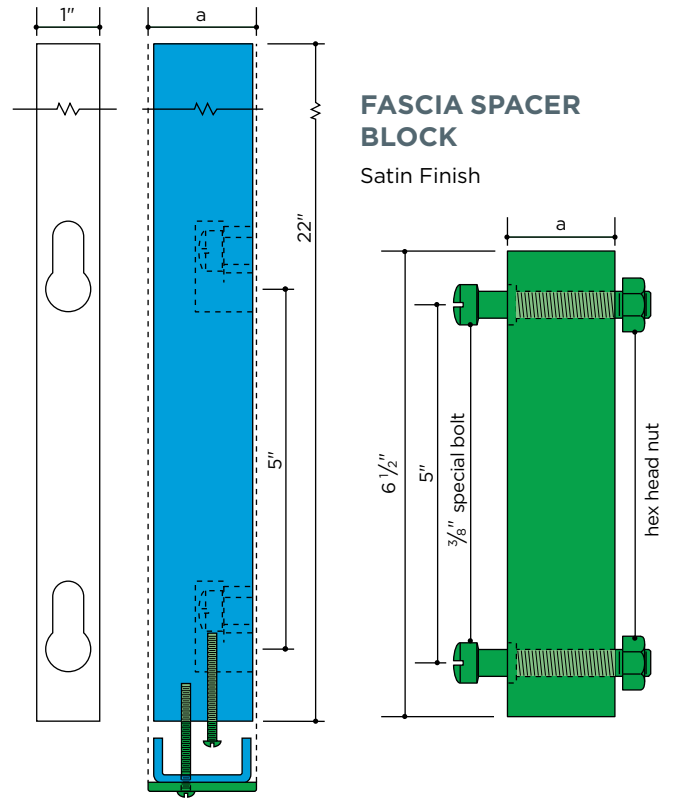

FASCIA SPACER BLOCK

Satin Finish

| | a | post |
|---------------------------------------|--------|------|
| ● 233B Aluminum | 1 1/2" | 230 |
| With stainless steel lower post cap * | | |
| ● 283 Aluminum | 2" | 280 |
| With stainless steel lower post cap * | | |
| * Satin Finish | | |

| | a |
|----------------------------|--------|
| ● 228 Stainless | 1/2" |
| Use with box stringers | |
| ● 229 Stainless | 1 1/2" |
| Use with channel stringers | |

Fascia Spacer Block Assembly

The spacer block is first fastened to the stringer. The keyhole in the anchor bar aligns with the holes in the tubular post. Post and anchor bar assembly are then fed over the bolt heads, into the keyhole slot and seated manually. Final tightening is achieved by drawing up the tightening screw in the lower post cap.

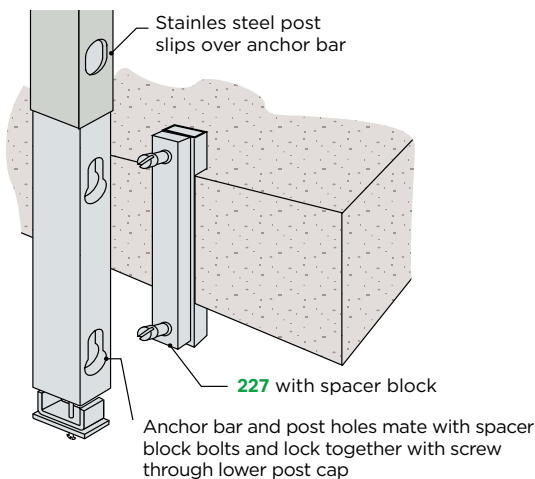

UPPER POST CAP

Satin Finish

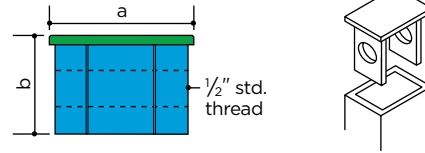

| Upper Cap | a | b | |
|-----------------|--------|---------|-------------------------|
| ● 231 Stainless | 1 1/2" | 1 1/4" | Fits stainless post 230 |
| ● 284 Stainless | 2" | 1 7/16" | Fits stainless post 280 |

POST ANCHOR FOR CAST STEPS

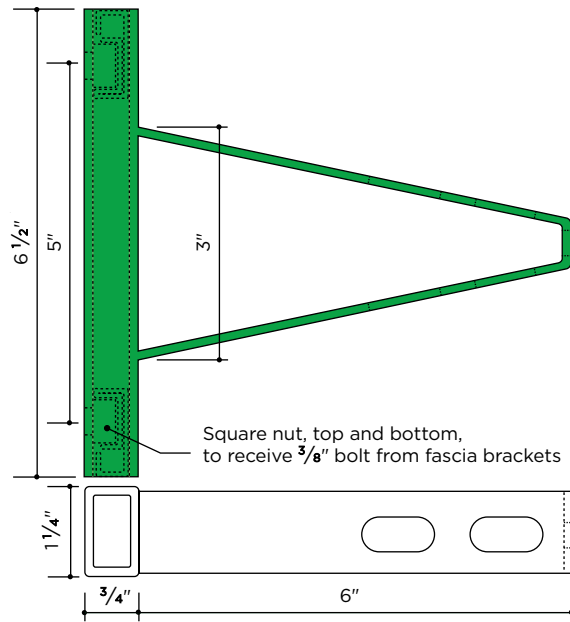

| | |
|-----------------|-------------------------------------------|
| ● 227 Stainless | For use with aluminum and bronze railings |
|-----------------|-------------------------------------------|

Post anchor 227 can be used with fascia brackets 228 and 229 to mount Carlstadt® aluminum or bronze posts. Cast post anchor into concrete with minimum slab thickness of 3" and minimum compressive strength of 3500 psi. Maximum recommended post spacing for 3" slabs is 30"; for slabs 4" thick and thicker, recommended maximum post spacing is 48".

Post Anchor Installation

Anchor is embedded in slab with anchor centered vertically in slab thickness. Front face of anchor should be flush with edge of slab. Square nuts move freely in pockets, receive 3/8" mounting bolts of Carlstadt® fascia brackets. Wide slots provide for lateral adjustment and vertical alignment.

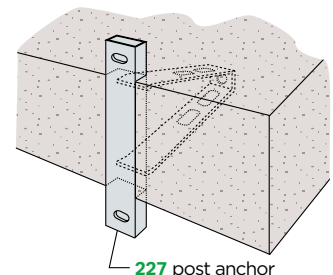

TUBING FOR RAILING POSTS

Mill Finish

Aluminum
6063-T6
20' lengths

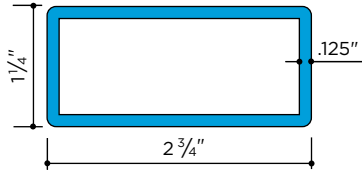

● **6434** Aluminum 1.123 lb/ft Fittings: N

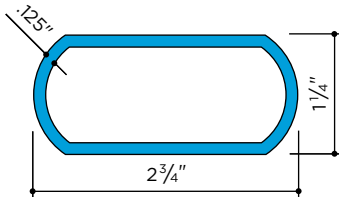

● **6435** Aluminum 1.075 lb/ft Fittings: N

Nickel-Silver
C79800
16' lengths

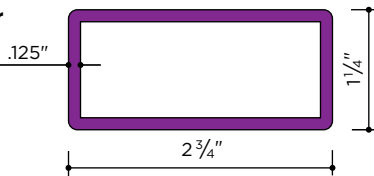

● **1334** Nickel-Silver 3.40 lb/ft Fittings: N

HIGH STRENGTH CONNECTORAIL® POSTS

Aluminum only, Alloy 6063-T832

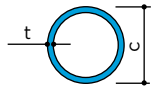

Drawn pipe precut to post lengths.
Clear anodized or mill finish

| | Pipe | Sched. | Length | c | t | |
|---------------|----------|--------|--------|-----|--------|-------|
| ● 7103 | Aluminum | 1 1/4" | 10 | 38" | 1.660" | .109" |
| ● 7104 | Aluminum | 1 1/4" | 10 | 50" | 1.660" | .109" |
| ● 7403 | Aluminum | 1 1/4" | 40 | 38" | 1.660" | .140" |
| ● 7404 | Aluminum | 1 1/4" | 40 | 50" | 1.660" | .140" |
| ● 7203 | Aluminum | 1 1/2" | 10 | 38" | 1.900" | .109" |
| ● 7204 | Aluminum | 1 1/2" | 10 | 50" | 1.900" | .109" |
| ● 7503 | Aluminum | 1 1/2" | 40 | 38" | 1.900" | .145" |
| ● 7504 | Aluminum | 1 1/2" | 40 | 50" | 1.900" | .145" |

DRAWN ALUMINUM HANDRAIL PIPE

Aluminum Alloy 6063-T832, 20' lengths

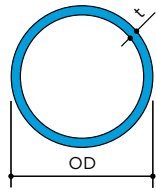
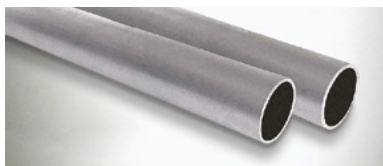

| Nominal Size | Sched. | OD | ID | t | lb/ft |
|--------------|--------|--------|--------|-------|-------|
| 1 1/4" | 10 | 1.660" | 1.442" | .109" | .625 |
| 1 1/4" | 40 | 1.660" | 1.380" | .140" | .785 |
| 1 1/2" | 10 | 1.900" | 1.682" | .109" | .721 |
| 1 1/2" | 40 | 1.900" | 1.610" | .145" | .940 |

This premium quality drawn pipe has an extra smooth surface. Its harder temper gives it high strength. See pages 16-27 for stock pipe fittings. Available in clear anodized or mill finish.

● ALUMINUM ● NICKEL-SILVER ● STAINLESS

PIPE ANCHOR PLUGS

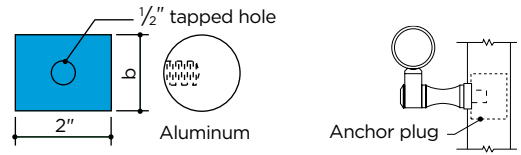

| | Pipe | Sched. | b | |
|---------------|-----------|--------|----|--------|
| ● 7162 | Aluminum | 1 1/4" | 10 | 1.427" |
| ● 7462 | Aluminum | 1 1/4" | 40 | 1.360" |
| ● 7262 | Aluminum | 1 1/2" | 10 | 1.667" |
| ● 7562 | Aluminum | 1 1/2" | 40 | 1.585" |
| ● 9362 | Stainless | 1 1/2" | 5 | 1.750" |

Anchor plugs provide secure mounting for brackets supporting second or third rails. Aluminum anchor plugs are machined from solid extruded stock; the stainless steel anchor plug is fabricated from heavy metal.

COVER FLANGES

Satin Finish

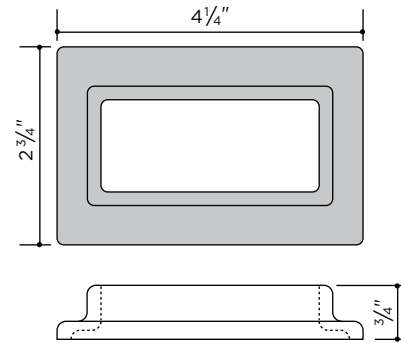

● **774** Aluminum Fits posts **424, 6424, and 6434**
● **1374** Nickel-Silver Fits Nickel-Silver post **1334**

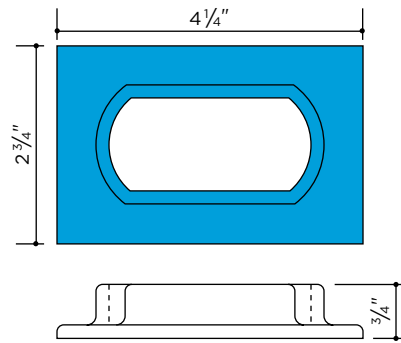

● **775** Aluminum Fits aluminum post **6435**

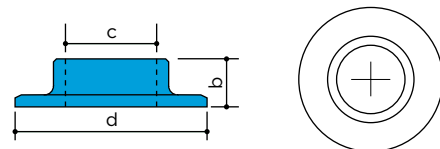

| | Pipe | b | c | d | |
|---------------|----------|--------|----|--------|----------|
| ● 710* | Aluminum | 1 1/4" | 1" | 1.688" | 3 13/16" |
| ● 711* | Aluminum | 1 1/2" | 1" | 1.938" | 4" |

* Also available in clear anodized AA-M32-C22-A31 (204R1)

● ALUMINUM ● NICKEL-SILVER

FASCIA FLANGES

Mill Finish

Sleeve-type fascia flanges are provided for mounting on solid or channel fascias and stringers. The post slips into the pocket of the fascia flange and is anchored with concealed set screws. The bottom extension of each fascia flange matches the profile of the post and is trimmed to match its top.

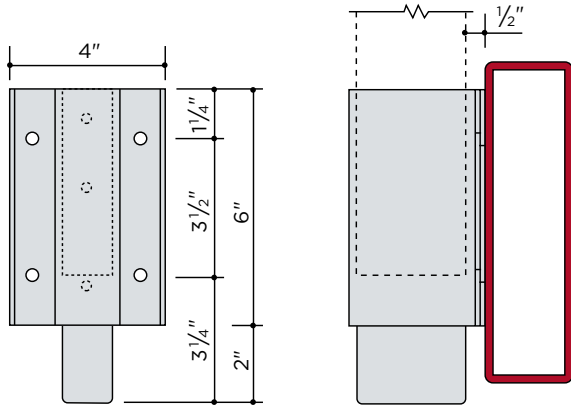

Elevation of **408**

Fascia flange **408** used with box stringer.

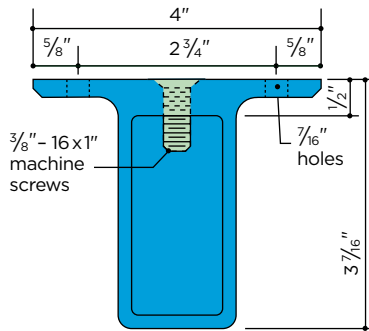

● **408** Aluminum
Fits aluminum post **6434**

See page 71 for a complete range of Carlstadt® fascia flanges.

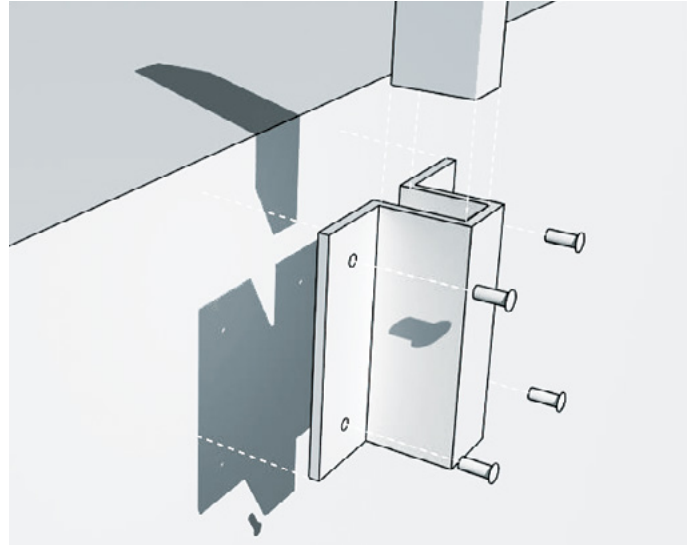

POST CAPS

Satin Finish, except as noted

Caps for hollow Carlstadt® posts have a flange extending inside to receive and support the thread of the bracket arm.

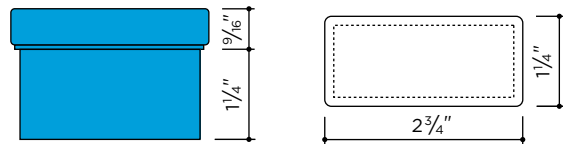

● **6434N** Aluminum

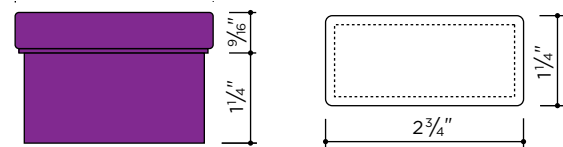

● **1334N** Nickel-Silver

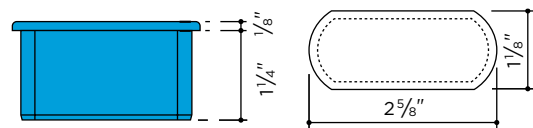

● **6435N** Aluminum

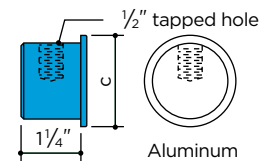

| | Pipe | Sched. | c |
|----------------|-----------------|--------|--------|
| ● 7180* | Aluminum 1 1/4" | 10 | 1.660" |
| ● 7480* | Aluminum 1 1/4" | 40 | 1.660" |
| ● 7280* | Aluminum 1 1/2" | 10 | 1.900" |
| ● 7580* | Aluminum 1 1/2" | 40 | 1.900" |

*Clear anodized AA-M32-C22-A31 (204R1)

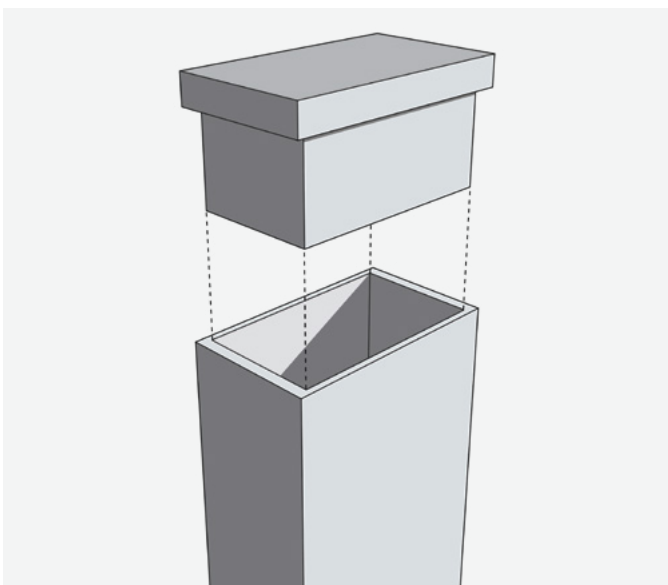

● ALUMINUM ● BRONZE ● NICKEL-SILVER ● STAINLESS

SELF-ALIGNING

Satin Finish

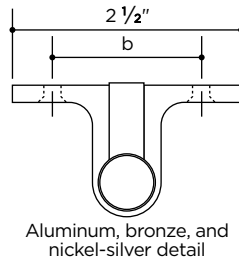
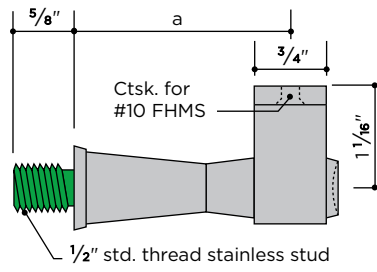

| | a | b |
|----------------------|--------|----------|
| ● 441 Aluminum | 2 1/4" | 1 5/8" |
| ● 442 Aluminum | 2 3/4" | 1 5/8" |
| ● 841 Bronze | 2 1/4" | 1 5/8" |
| ● 1341 Nickel-Silver | 2 1/4" | 1 5/8" |
| ● 241 Stainless | 2 1/4" | 1 13/16" |

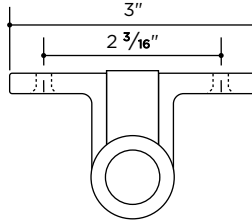
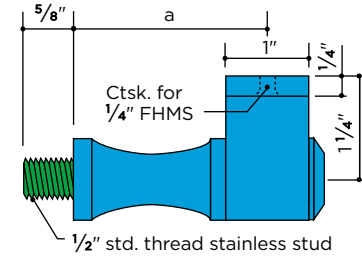
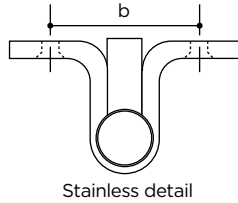

For use with Carlstadt® handrail moulding

| | a |
|----------------|--------|
| ● 309 Aluminum | 3 1/4" |
| ● 312 Aluminum | 2 3/8" |

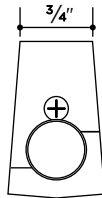
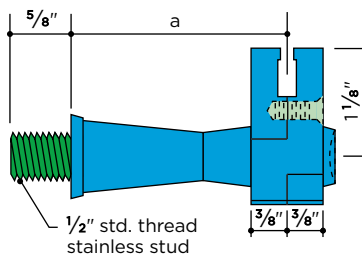

For use with Carlstadt® T-handrail moulding

| | a |
|----------------|--------|
| ● 439 Aluminum | 2 1/4" |
| ● 440 Aluminum | 2 3/4" |

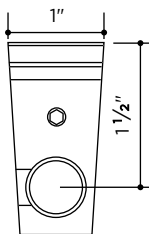
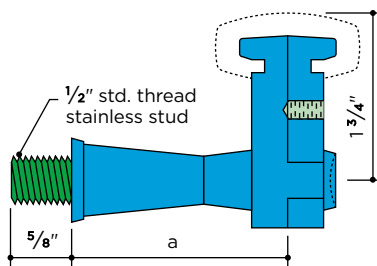

For use with Carlsrail® handrail moulding

| | a |
|----------------|--------|
| ● 171 Aluminum | 2 1/4" |
| ● 172 Aluminum | 2 3/4" |

POST BRACKET ADAPTER

Satin Finish

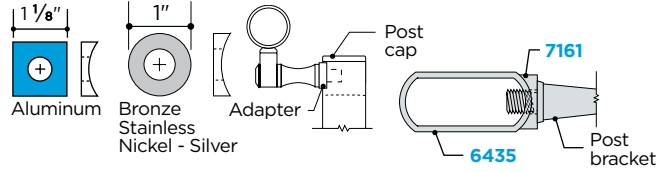

| | Pipe Size | Schedule | Clear Hole |
|----------------------|-----------|----------|------------|
| ● 7161* Aluminum | 1 1/4" | all | 1/2" |
| ● 7261* Aluminum | 1 1/2" | all | 1/2" |
| ● 8661 Bronze | 1 1/4" | all | 1/2" |
| ● 8861 Bronze | 1 1/2" | all | 1/2" |
| ● 1361 Nickel-Silver | 1 1/2" | all | 1/2" |
| ● 9161 Stainless | 1 1/4" | all | 1/2" |
| ● 9361 Stainless | 1 1/2" | all | 1/2" |

* Also available in clear anodized AA-M10-C22-A31 (204R1)

POST BRACKET EXTENSIONS

Satin Finish

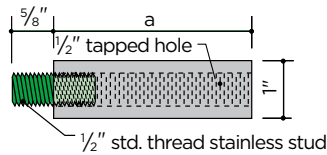

Designers should note that extending a bracket increases stress at its base and reduces its allowable load.

| Post | a |
|----------------------|--------|
| ● 462* Aluminum | 1 3/4" |
| ● 463* Aluminum | 3" |
| ● 862 Bronze | 1 3/4" |
| ● 863 Bronze | 3" |
| ● 1362 Nickel-Silver | 1 3/4" |
| ● 1366 Nickel-Silver | 3" |
| ● 245 Stainless | 1 3/4" |
| ● 246 Stainless | 3" |

Extensions may be cut to length to suit individual conditions.
* Also available in clear anodized AA-M10-C22-A31 (204R1)

POST BRACKET ANCHOR PLUGS

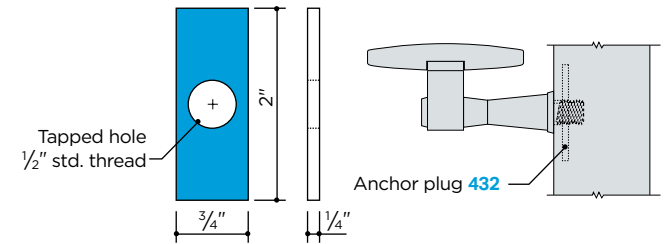

| | |
|----------------|----------------------------------------|
| ● 432 Aluminum | Fits with posts 430, 458, 459, and 830 |
|----------------|----------------------------------------|

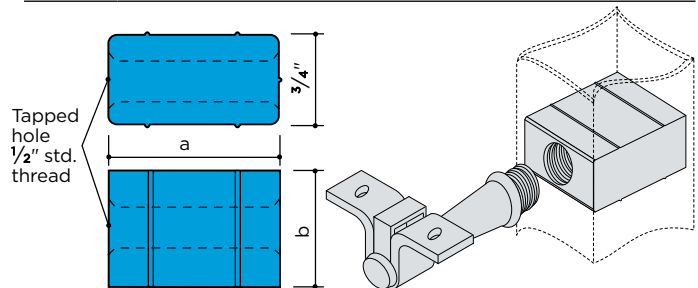

| | a | b | |
|----------------|-------|--------|------------------------------|
| ● 238 Aluminum | 1.34" | 1 1/8" | Fits with stainless post 230 |
| ● 279 Aluminum | 1.84" | 1 1/4" | Fits with stainless post 280 |

For Pipe Post Anchor Plugs, see page 22.

● ALUMINUM ● BRONZE ● NICKEL-SILVER ● STAINLESS

SELF-ALIGNING WALL BRACKETS

Satin Finish

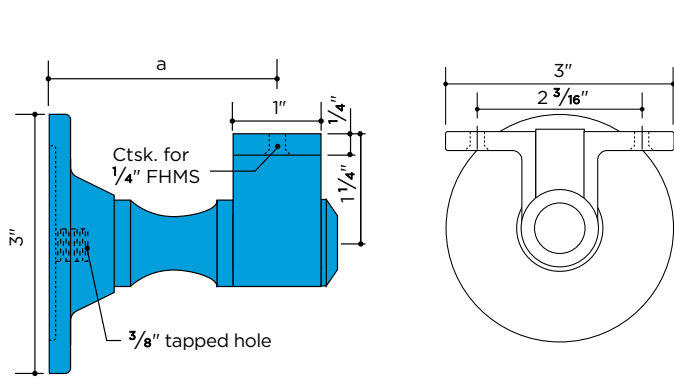

| For use with Carlstadt® handrail moulding | | a |
|-------------------------------------------|----------|--------|
| ● 313 | Aluminum | 2 5/8" |
| ● 314 | Aluminum | 3 1/8" |

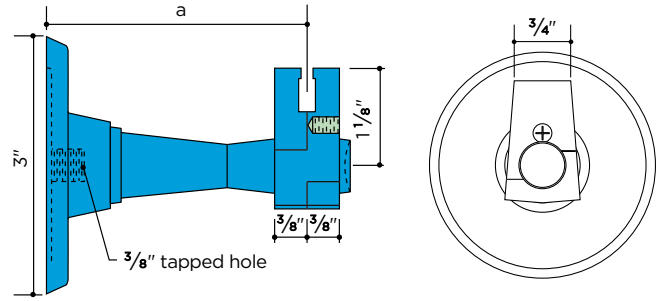

| For use with Carlstadt® T-handrail moulding | | a |
|---------------------------------------------|----------|--------|
| ● 418 | Aluminum | 3" |
| ● 419 | Aluminum | 3 1/2" |

WALL BRACKET EXTENSIONS

Satin Finish

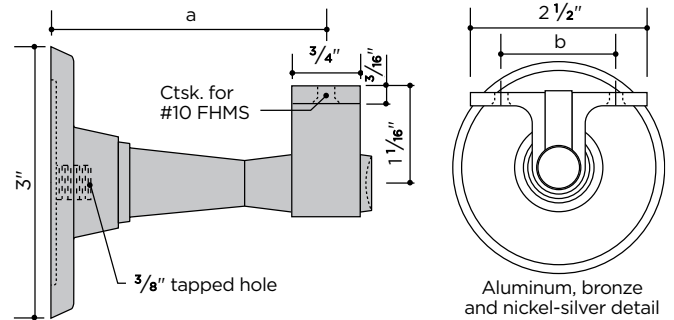

| | a | b | |
|--------|---------------|--------|----------|
| ● 443 | Aluminum | 3" | 1 5/8" |
| ● 444 | Aluminum | 3 1/2" | 1 5/8" |
| ● 844 | Bronze | 2 1/2" | 1 5/8" |
| ● 843 | Bronze | 3" | 1 5/8" |
| ● 1343 | Nickel-Silver | 3" | 1 5/8" |
| ● 271 | Stainless | 2 1/4" | 1 13/16" |
| ● 243 | Stainless | 3" | 1 13/16" |

Aluminum, bronze and nickel-silver detail

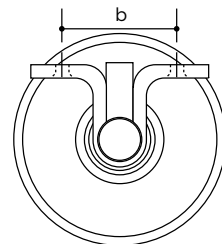

Stainless detail

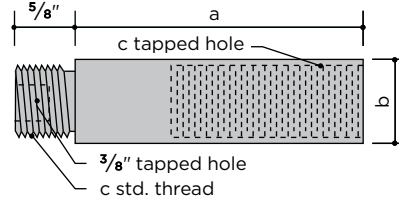

Designers should note that extending a bracket increases stress at its base and reduces its allowable load.

| | a | b | c | |
|---------|---------------|--------|--------|------|
| ● 414*† | Aluminum | 1 3/4" | 1 1/8" | 7/8" |
| ● 415*† | Aluminum | 3" | 1 1/8" | 7/8" |
| ● 464 | Aluminum | 1 3/4" | 1" | 3/4" |
| ● 465 | Aluminum | 3" | 1" | 3/4" |
| ● 864 | Bronze | 1 3/4" | 1" | 3/4" |
| ● 865 | Bronze | 3" | 1" | 3/4" |
| ● 1364 | Nickel-Silver | 1 3/4" | 1" | 3/4" |
| ● 1365 | Nickel-Silver | 3" | 1" | 3/4" |
| ● 247 | Stainless | 1 3/4" | 1" | 3/4" |
| ● 248 | Stainless | 3" | 1" | 3/4" |

Extensions may be cut to length to suit individual conditions.
 * Also available in clear anodized AA-M10-C22-A31 (204R1)
 † For use with 307, 308, 313, and 314 wall brackets.

Adjustable Bracket Detail

Post and upper post caps must be drilled and tapped to accept bracket arm. Recess of bracket arm has flat sides to accommodate wrench, which permits tightening without marring exposed surfaces. Handrail flange tilts to adjust to stair angle and is attached to handrail with machine screws. Pressure on tightening block prevents looseness and rattling.

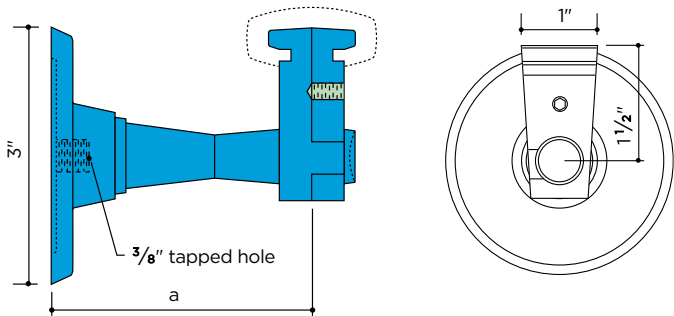
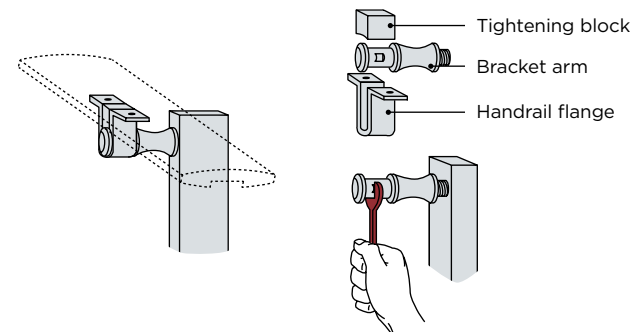

| For use with Carlsrail® handrail moulding | | a |
|-------------------------------------------|----------|--------|
| ● 175 | Aluminum | 2 1/4" |
| ● 173 | Aluminum | 3" |
| ● 174 | Aluminum | 3 1/2" |

● ALUMINUM ● BRONZE ● NICKEL-SILVER ● STAINLESS

TWO-PIECE MOUNTING BRACKETS

Satin Finish

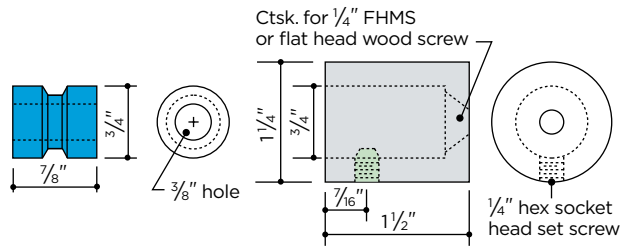

- 166* Aluminum
- 896 Bronze
- 196 Nickel-Silver
- 296 Stainless

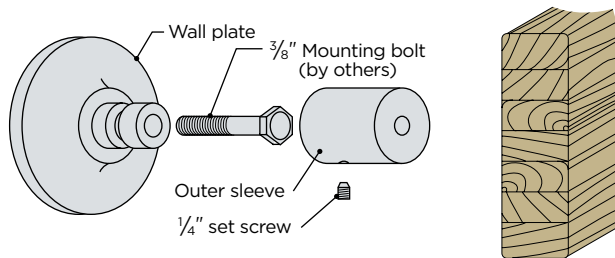
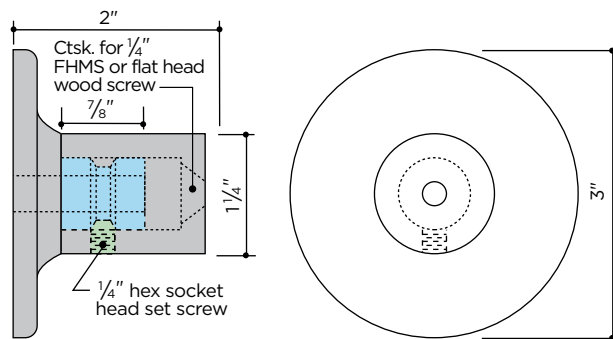

- 168* Aluminum
- 898 Bronze
- 298 Stainless

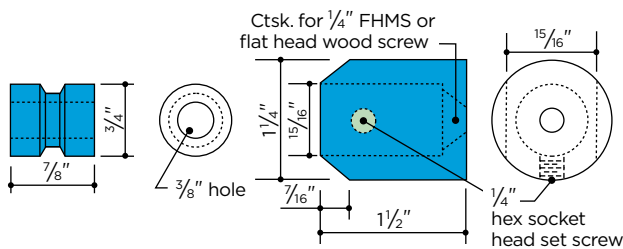

- 167 Aluminum Tapered

TWO-PIECE MOUNTING BRACKETS

Satin Finish

For wide wood handrails or metal handrails

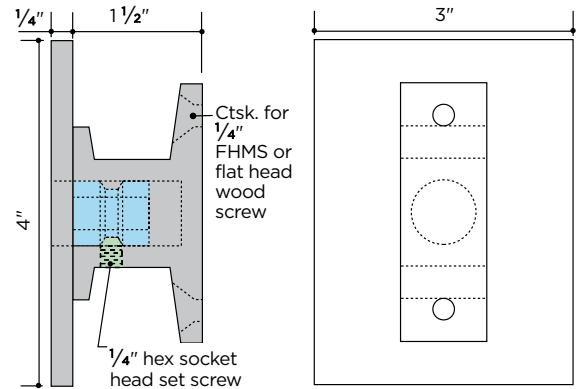

- 160* Aluminum
- 890 Bronze
- 290 Stainless

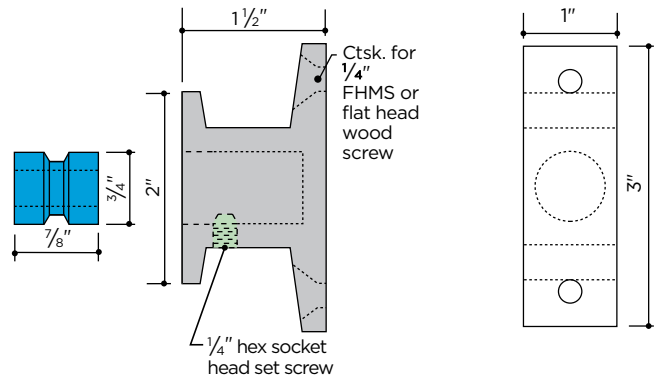

- 169* Aluminum
- 899 Bronze
- 299 Stainless

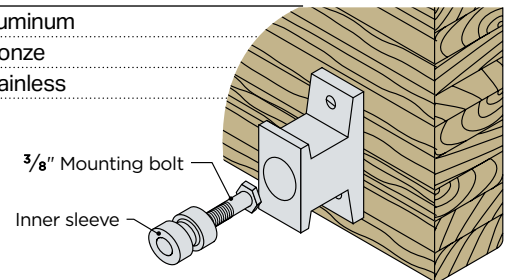

ADAPTERS

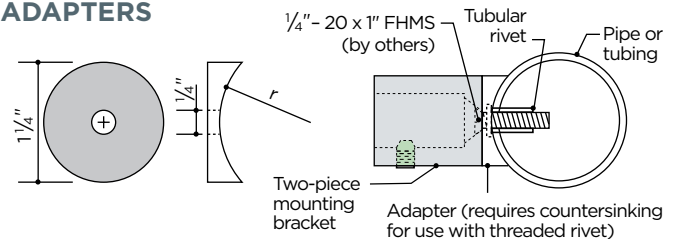

| | r | Use With |
|----------------------|-------|-----------|
| ● 7164* Aluminum | .830" | 1.660" OD |
| ● 7264* Aluminum | .950" | 1.900" OD |
| ● 8864 Bronze | .950" | 1.900" OD |
| ● 8964 Bronze | .750" | 1.500" OD |
| ● 5264 Nickel-Silver | .750" | 1.500" OD |
| ● 5364 Nickel-Silver | .950" | 1.900" OD |
| ● 9164 Stainless | .830" | 1.660" OD |
| ● 9364 Stainless | .950" | 1.900" OD |

* Also available in clear anodized AA-M32-C22-A31 (204R1)

● ALUMINUM ● BRONZE ● NICKEL-SILVER ● STAINLESS ● STEEL

VERTICAL MOUNTING BRACKET

Satin Finish

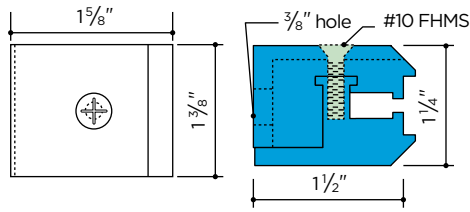

● **151*** Aluminum

* Also available in clear anodized AA-M10-C22-A31 (204R1)

Vertical mounting bracket **151** is designed for mounting handrail on edge to provide a wall guard or bumper. Carlstadt® T-handrail mouldings **6402**, **6405**, or **6407** can be mounted without drilling and tapping. Bracket is also suitable for mounting handrail on top of a parapet or wall.

Assembly Detail

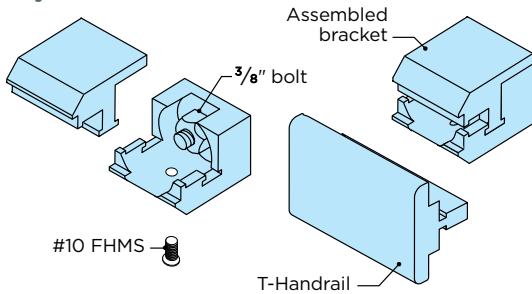

Use 3/8" machine screw, stud or hex head bolt for fastening to wall.

Installation Details

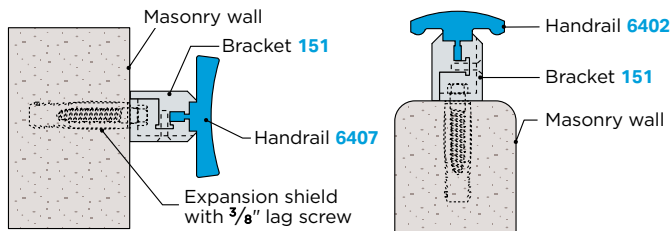

THREADED BUSHING BRACKETS

Satin Finish

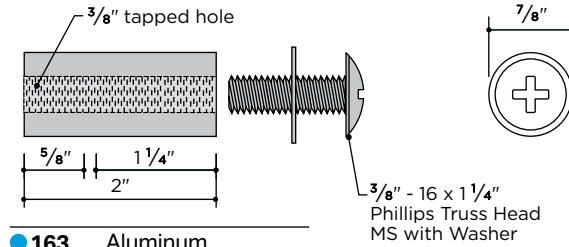

● **163** Aluminum
● **63** Stainless

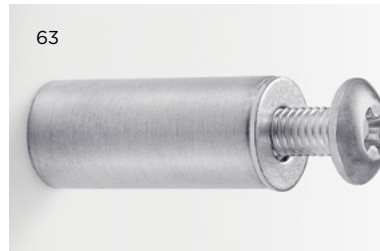

Installation Details

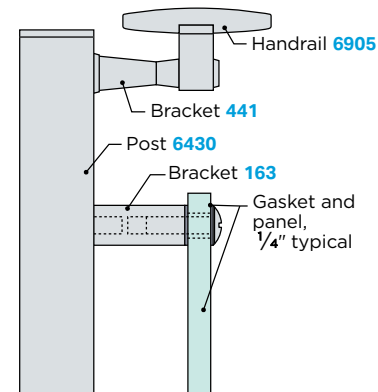

Threaded Bushing Brackets are used with threaded studs, machine screws, or bolts to install handrails or panels. Brackets may be cut to length as required. Brackets are furnished with aluminum Phillips Truss Head machine screws and washers.

BOLTS AND ANCHORS for handrail wall brackets

Hanger Bolt



● Steel 3/8" x 3"

Hex Head Lag Screw



● Aluminum 3/8" x 2"
● Brass 3/8" x 2" (Plain or Finished)
● Nickel-Silver 3/8" x 2" (Finished)
● Stainless 3/8" x 2"

Post Bracket Hanger Bolt



● Steel 5/16" x 1 1/2" / 1/2" - 13 x 3/8"

Heavy-Duty Double Machine Bolt Anchor (Zinc Alloy)

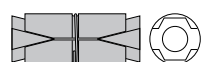

Non-calking machine bolt anchor for use in masonry materials of questionable strength or where heavy shear loads are encountered. Thread accommodates 3/8" - 16 stud or machine bolt (supplied by others). Drill hole size of 3/4" diameter by 2 1/4" deep.

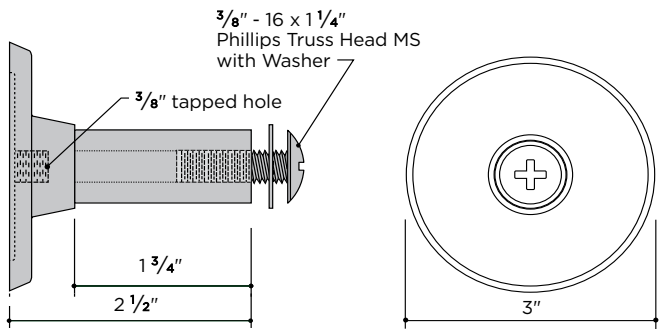

● **164** Aluminum
● **64** Stainless

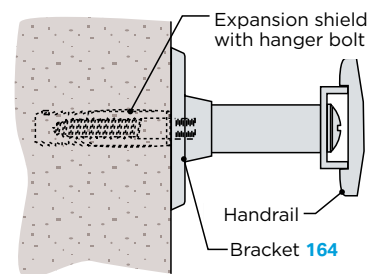

CENTER POST BRACKETS

Satin Finish, except as noted

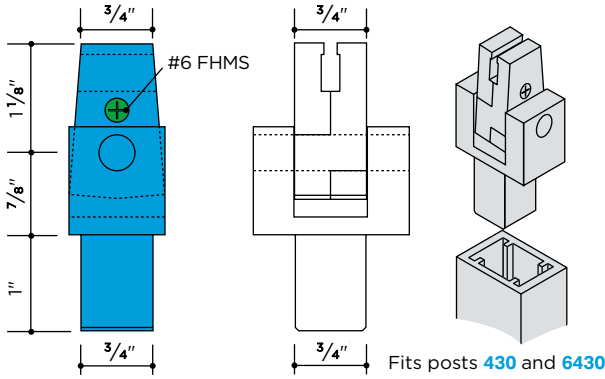

Center post brackets permit handrail to be centered directly over post, yet allow it to tilt to conform to stair incline. Bracket is secured to post with pin or screw.

● 152 Aluminum for Carlstadt® T-handrail moulding

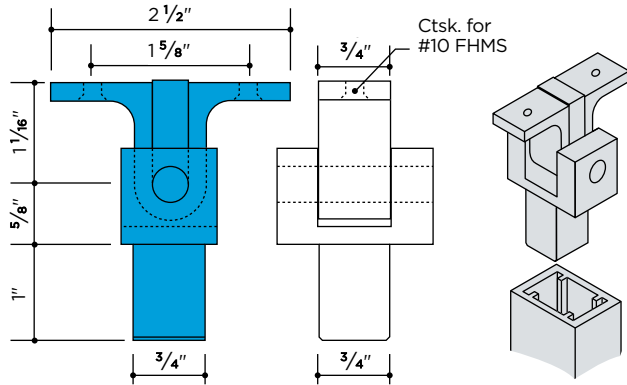

● 161 Aluminum Curved for pipe, fits posts 430 and 6430
 ● 162 Aluminum Flat for moulding, fits posts 430 and 6430

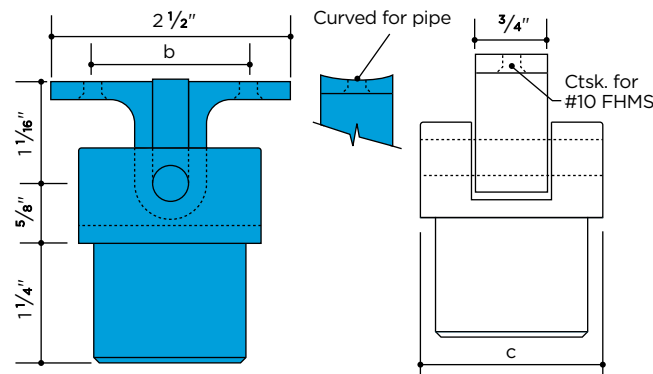

For center mounting of flat-bottomed handrail onto aluminum Connectorail® posts

| Flat | Pipe | Sched. | c | b |
|-------|-----------------|--------|--------|-------|
| ● 144 | Aluminum 1 1/4" | 40 | 1.660" | 15/8" |
| ● 145 | Aluminum 1 1/2" | 40 | 1.900" | 15/8" |

For center mounting of pipe or rounded handrail onto aluminum Connectorail® posts

| Curved | Pipe | Sched. | c | b |
|--------|-----------------|--------|--------|-------|
| ● 142* | Aluminum 1 1/4" | 40 | 1.660" | 15/8" |
| ● 143* | Aluminum 1 1/2" | 40 | 1.900" | 15/8" |

* Also available in clear anodized AA-M10-C22-A31 (204R1)

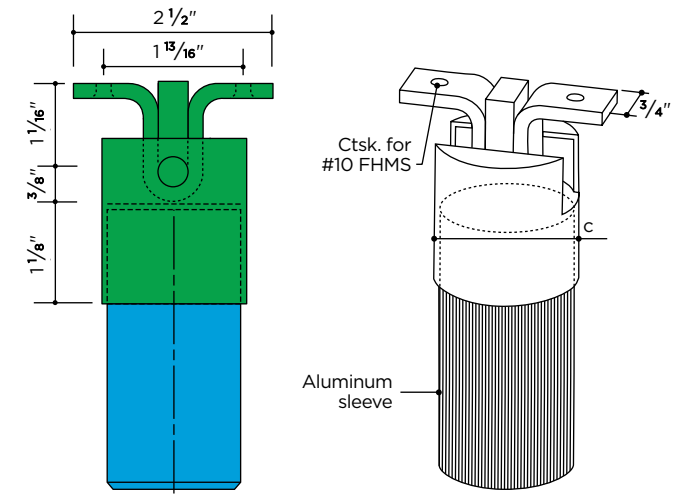

For center mounting of flat-bottomed handrail moulding onto stainless Connectorail® posts

| Flat | Pipe | Sched. | c |
|-------|------------------------|--------|--------|
| ● 207 | Stainless Steel 1 1/2" | 5 | 1.900" |

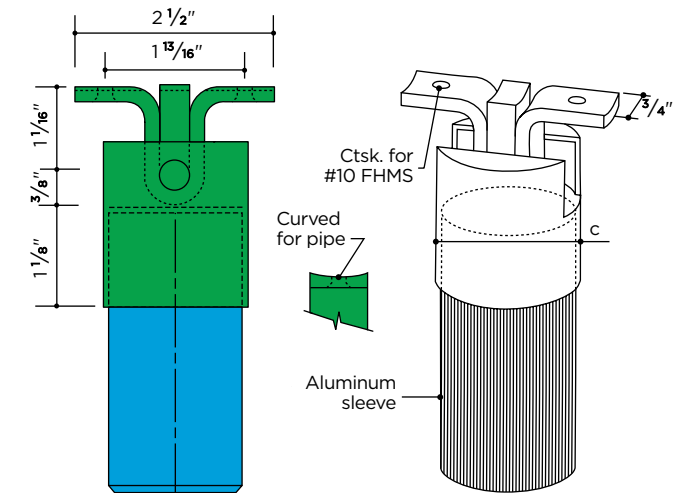

For center mounting of handrail pipe or rounded handrail onto stainless Connectorail® posts

| Curved | Pipe | Sched. | c |
|--------|------------------------|--------|--------|
| ● 208 | Stainless Steel 1 1/2" | 5 | 1.900" |

● ALUMINUM ● BRONZE ● NICKEL-SILVER ● STAINLESS

PANEL CLIPS

For aluminum pipe only, Mill Finish or Clear Anodized

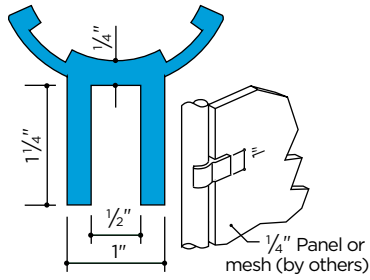

| | Pipe |
|-----------|-----------------|
| ● 7460-5* | Aluminum 1 1/4" |
| ● 7460† | Aluminum 1 1/4" |
| ● 7560-5* | Aluminum 1 1/2" |
| ● 7560† | Aluminum 1 1/2" |

* 5' Length
† Packages of 4 pieces

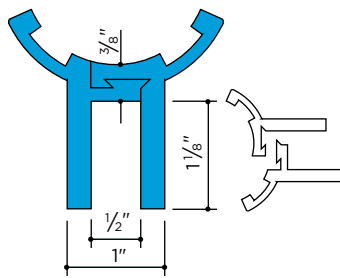

| | Pipe |
|----------|-----------------|
| ● 7260** | Aluminum 1 1/2" |

Packages of 4 sets. ** Two-piece assembly

For mounting to flat surface, Satin Finish

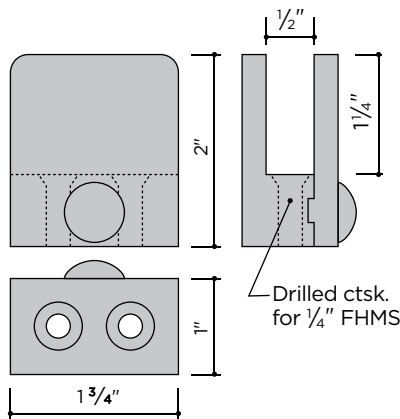
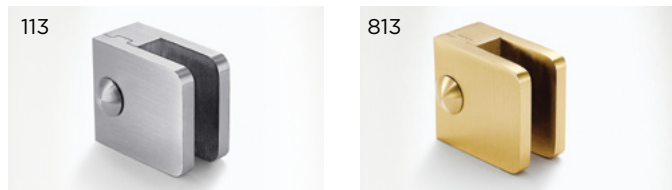

| | | | |
|-------|----------|-------|---------------|
| ● 113 | Aluminum | ● 413 | Nickel-Silver |
| ● 813 | Bronze | ● 213 | Stainless |

Plug (packed separately) is inserted following installation and may be held in place with epoxy or other sealant.

Installation Detail

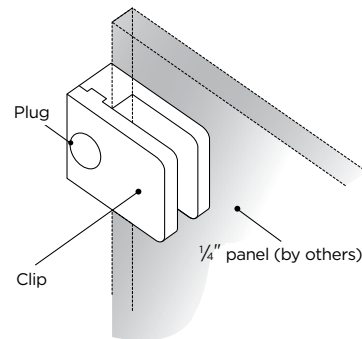
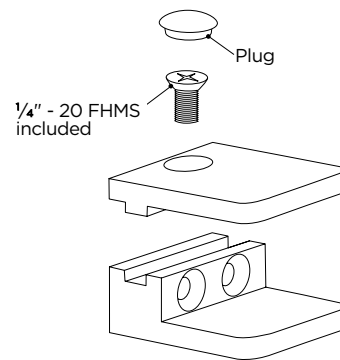
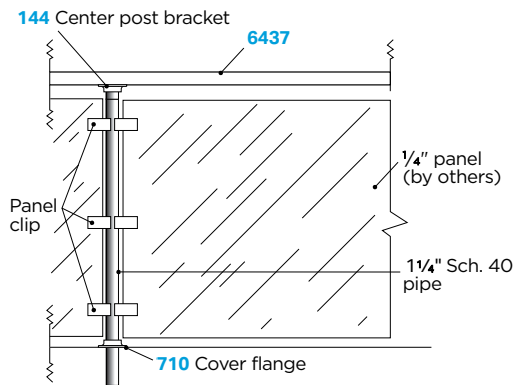
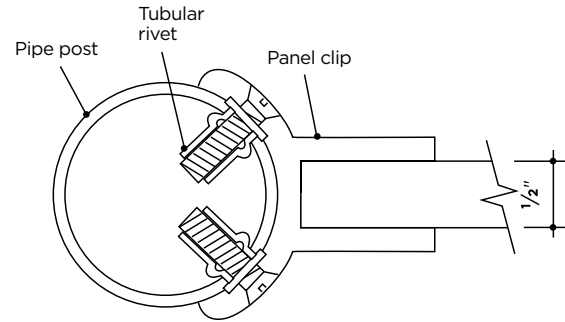

HANDRAIL BRACKETS

Turtle Back Zoo, West Orange, NJ, Bismark Construction Corp., Newark, NJ (Fabricator), USA Architects (Architect), Planner and Interior Designers, Somerville, NJ (Designers).

For convenience and ease of reference, all of the handrail brackets that appear in various sections of our catalog are brought together in this section. **Included are brackets for wall, post, center rail and vertical mounting; for use with moulding or flat bars; for pipe railings; and for specific applications.**

- **Aluminum:** Cast brackets are made of high-strength alloy Almag 35—suitable for clear anodizing. Extruded and machined brackets are of alloy 6063—suitable for anodizing, including most of the hard coat anodic processes (black anodizing may result in inconsistent matches; consult your anodizer before specifying). **All, except as noted, are satin finished.** Pipe rail brackets are stocked with a clear anodized finish—AA-M32-C22-A31 (204R1)—as well as plain. Aluminum brackets cover a wide range of applications, including wall- and post-mounted brackets, brackets for center rails, and brackets for vertical mounting of rails or panels.
- **Bronze:** Cast brackets are made of alloy C86500 for close color match with extruded architectural bronze C38500 and red brass C23000. Extruded and machined brackets are of C38500. All, except as noted, are satin finished and lacquered.
- **Nickel-Silver:** Cast brackets closely match extruded nickel-silver handrails. Extruded and machined brackets are of alloy C79800. All, except as noted, are satin finished and lacquered.

- **Stainless Steel:** Brackets are made of 18-8 chrome-nickel alloy, stainless type 304, for high corrosion resistance. All, except as noted, are satin finished.
- **Malleable Iron and Stamped Steel:** All types are stocked with flat top member for mouldings and with curved top member for pipe rails. They may be welded or mechanically fastened to the rail. Pipe rail brackets are supplied galvanized as well as plain.
- **Titanium:** Silver-gray and softly reflective in appearance, titanium is a non-reactive metal and can be combined with bronze, aluminum, steel, or stainless handrails. Eco-friendly and low maintenance, it has outstanding corrosion resistance and requires no additional finishing. Because of its high strength, Julius Blum & Co., Inc. is able to design thinner and lighter handrail brackets.

Julius Blum & Co., Inc.'s handrail brackets have been designed to meet or exceed accepted safety standards and have been laboratory tested. Test results are available upon request.

Fasteners, except as noted, are not included. All items are carried in stock in substantial quantities and are available for prompt shipment.



Primary School

CARLSTADT® SELF-ALIGNING WALL BRACKETS

These wall brackets, available in aluminum, bronze, nickel-silver, and stainless steel, are self-aligning. Once the concealed wall attachment is made, the bracket yoke—which attaches to the handrail—rotates freely until the chosen handrail is properly aligned. Various styles are available to coordinate with different handrail mouldings and with pipe railings.

CAST, STAMPED AND EXTRUDED WALL BRACKETS

These wall brackets are more traditional in style and may be used in a multitude of applications. The various styles allow for concealed fastening or by attachment with a single 3/8" mounting bolt through the wall flange center.



313



173



370



1622



843



321



478



275

CARLSTADT® SELF-ALIGNING POST BRACKETS

Post brackets, available in aluminum, bronze, nickel-silver, and stainless steel, are post-mounted variations of the Carlstadt® wall brackets. A solid post is prepared by drilling and tapping to provide a match to the 1/2" stainless stud included as part of the bracket. The stainless stud may be replaced with a post bracket hanger bolt for attachment to a wood post. Hollow posts require a clear hole to be drilled with a tapped post cap or anchor plug inserted to accept the stud.

VERTICAL MOUNTING BRACKETS

The mounting brackets are useful for mounting handrails vertically, as in an elevator cab or hospital corridor. These brackets are often used with wood handrails, vertically mounted. They are also suitable for mounting handrails on top of a parapet or knee wall. Adapters are available to permit attachment to pipe or round tube.



439



1341



163



290



222



309



896



151

● ALUMINUM ● BRONZE ● NICKEL-SILVER ● STAINLESS ● MALLEABLE IRON / STEEL ● TITANIUM

EXTRUDED - UNPOLISHED

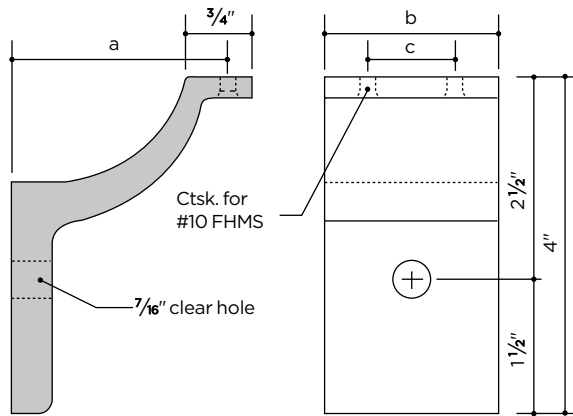

| | | a | b | c |
|--------|---------------|--------|--------|------|
| ● 477 | Aluminum | 2 1/2" | 2" | 1" |
| ● 497 | Aluminum | 3" | 2" | 1" |
| ● 891 | Bronze | 2 1/2" | 2" | 1" |
| ● 893 | Bronze | 3" | 2" | 1" |
| ● 193 | Nickel-Silver | 3" | 2" | 1" |
| ● 217† | Stainless | 2 1/2" | 2" | 1" |
| ● 219† | Stainless | 3" | 2" | 1" |
| ● 9977 | Titanium | 2 1/2" | 1 1/2" | 3/4" |

† Satin Finish

CAST

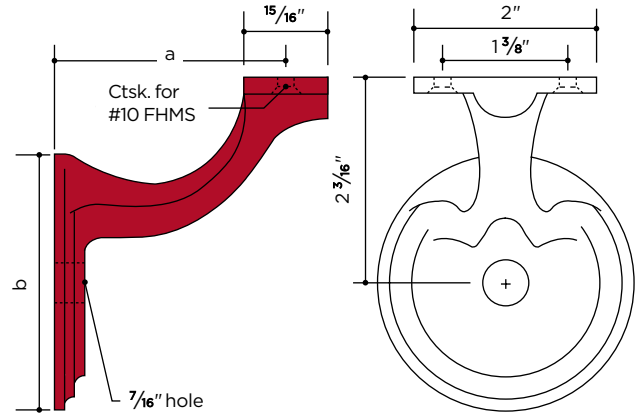

| | | a | b |
|-------|----------------|--------|--------|
| ● 381 | Malleable Iron | 2 1/2" | 2 3/4" |
| ● 305 | Malleable Iron | 3" | 3 1/4" |

STAMPED

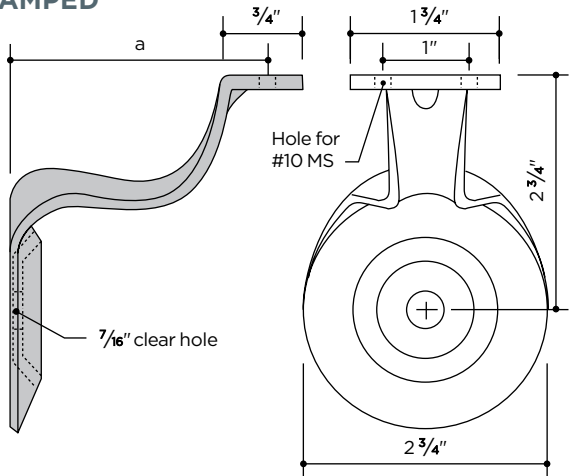

| | | a |
|----------|-----------|--------|
| ● 621 | Steel | 2 1/2" |
| ● 625 | Steel | 3" |
| ● 1021†† | Stainless | 2 1/2" |

†† Burnished

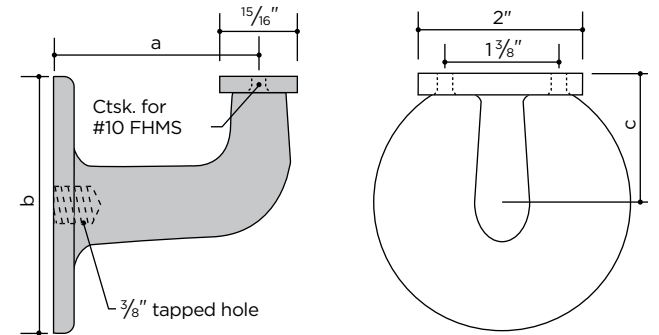

| | | a | b | c |
|-------|----------------|--------|--------|---------|
| ● 371 | Aluminum | 2 1/2" | 3 1/8" | 1 9/16" |
| ● 302 | Aluminum | 3 1/8" | 3 3/4" | 1 7/8" |
| ● 370 | Bronze | 2 1/2" | 3 1/8" | 1 9/16" |
| ● 304 | Bronze | 3 1/8" | 3 3/4" | 1 7/8" |
| ● 170 | Nickel-Silver | 2 1/2" | 3 1/8" | 1 9/16" |
| ● 270 | Stainless | 2 1/2" | 3 1/8" | 1 9/16" |
| ● 377 | Malleable Iron | 2 1/2" | 3 1/8" | 1 9/16" |
| ● 385 | Malleable Iron | 3" | 3 1/8" | 1 9/16" |

WALL BRACKET FILLER

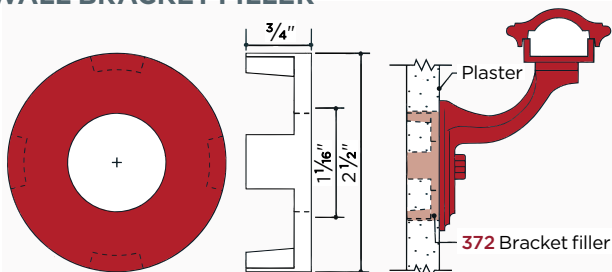

● 372 Malleable Iron Set bracket filler in plaster wall before mounting handrail bracket.

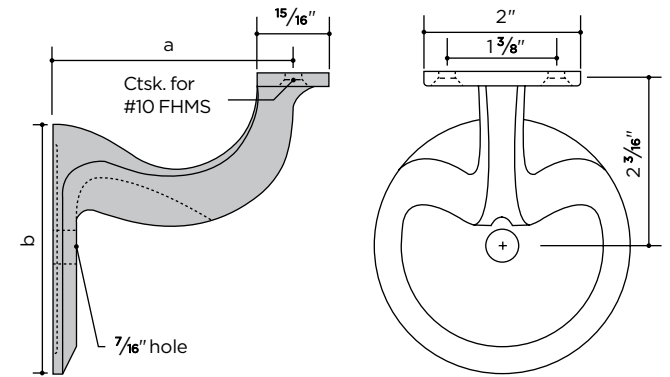

| | | a | b |
|--------|-----------|--------|--------|
| ● 383 | Aluminum | 2 1/2" | 2 3/4" |
| ● 315 | Aluminum | 3" | 3 1/4" |
| ● 387 | Bronze | 2 1/2" | 2 3/4" |
| ● 317 | Bronze | 3" | 3 1/4" |
| ● 1087 | Stainless | 2 1/2" | 2 3/4" |

● ALUMINUM ● BRONZE ● NICKEL-SILVER ● STAINLESS ● MALLEABLE IRON / STEEL

EXTRUDED - UNPOLISHED

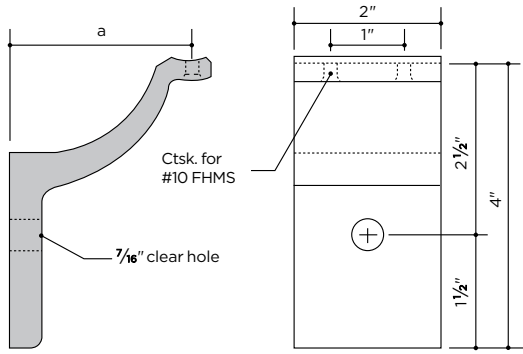

| | | a |
|--------|---------------|--------|
| ● 478* | Aluminum | 2 1/2" |
| ● 498* | Aluminum | 3" |
| ● 892 | Bronze | 2 1/2" |
| ● 894 | Bronze | 3" |
| ● 192 | Nickel-Silver | 2 1/2" |
| ● 218† | Stainless | 2 1/2" |
| ● 220† | Stainless | 3" |

CAST

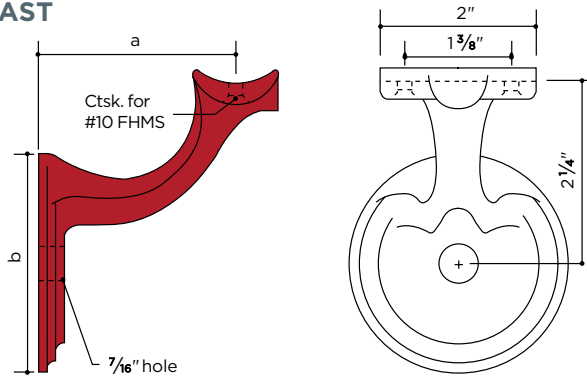

| | | a | b |
|----------|-----------------------------|--------|--------|
| ● 382 | Malleable Iron | 2 1/2" | 2 3/4" |
| ● 382-B | Malleable Iron (Black)^ | 2 1/2" | 2 3/4" |
| ● 382-W | Malleable Iron (White)^ | 2 1/2" | 2 3/4" |
| ● 1382** | Malleable Iron (Galvanized) | 2 1/2" | 2 3/4" |
| ● 306 | Malleable Iron | 3" | 3 1/4" |
| ● 1306** | Malleable Iron (Galvanized) | 3" | 3 1/4" |

^ Powdercoated

STAMPED

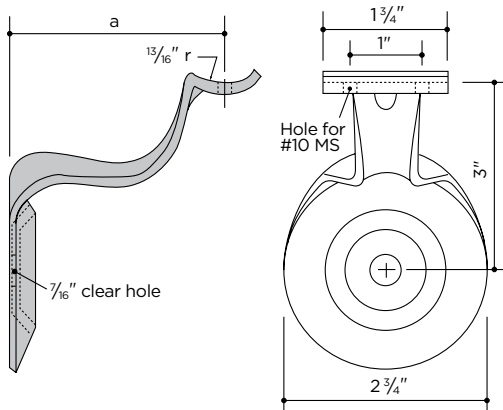

| | | a |
|----------|--------------------|--------|
| ● 622 | Steel | 2 1/2" |
| ● 1622** | Steel (Galvanized) | 2 1/2" |
| ● 1022†† | Stainless | 2 1/2" |
| ● 626 | Steel | 3" |
| ● 1626** | Steel (Galvanized) | 3" |
| ● 1026†† | Stainless | 3" |

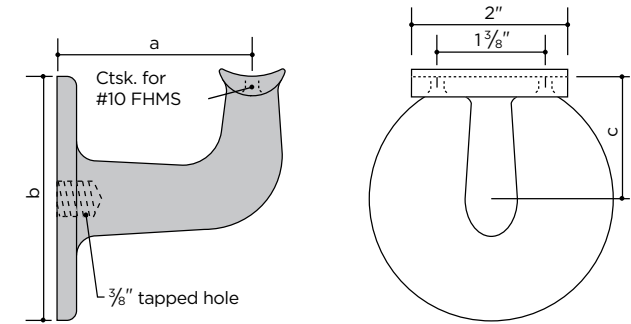

| | | a | b | c |
|----------|-----------------------------|--------|--------|---------|
| ● 376* | Aluminum | 2 1/2" | 3 1/8" | 1 9/16" |
| ● 389* | Aluminum | 3 1/8" | 3 3/4" | 1 7/8" |
| ● 375 | Bronze | 2 1/2" | 3 1/8" | 1 9/16" |
| ● 319 | Bronze | 3 1/8" | 3 3/4" | 1 7/8" |
| ● 176 | Nickel-Silver | 2 1/2" | 3 1/8" | 1 9/16" |
| ● 275 | Stainless | 2 1/2" | 3 1/8" | 1 9/16" |
| ● 378 | Malleable Iron | 2 1/2" | 3 1/8" | 1 9/16" |
| ● 386 | Malleable Iron | 3" | 3 1/8" | 1 9/16" |
| ● 1378** | Malleable Iron (Galvanized) | 2 1/2" | 3 1/8" | 1 9/16" |
| ● 1386** | Malleable Iron (Galvanized) | 3" | 3 1/8" | 1 9/16" |

CAST POST BRACKET

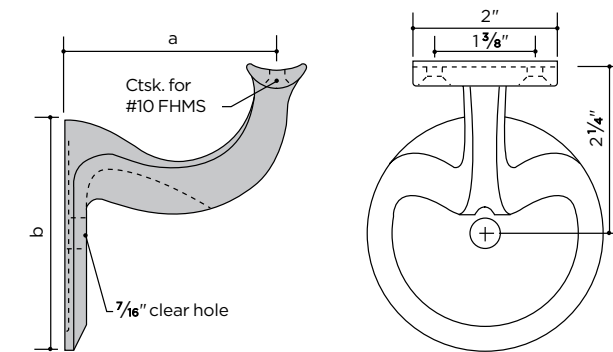
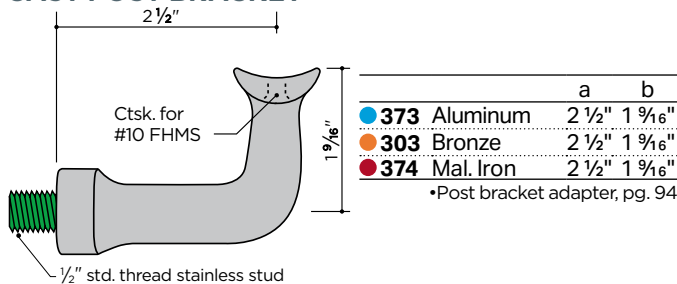

| | | a | b |
|--------|-----------|--------|--------|
| ● 384* | Aluminum | 2 1/2" | 2 3/4" |
| ● 316* | Aluminum | 3" | 3 1/4" |
| ● 388 | Bronze | 2 1/2" | 2 3/4" |
| ● 318 | Bronze | 3" | 3 1/4" |
| ● 1088 | Stainless | 2 1/2" | 2 3/4" |

* Also available in clear anodized AA-M10-C22-A31 (204R1)
† Satin Finish †† Burnished

** Galvanized brackets may require redrilling and tapping of holes fouled by zinc

● ALUMINUM ● BRONZE ● NICKEL-SILVER ● STAINLESS

SELF-ALIGNING

Satin Finish

For use with pipe railings

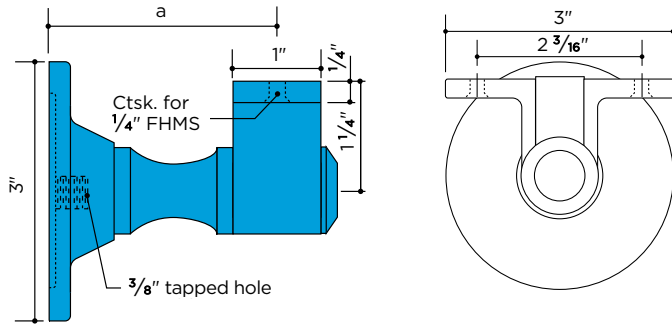

| For use with Carlstadt® handrail moulding | | a |
|-------------------------------------------|----------|--------|
| ● 313 | Aluminum | 2 5/8" |
| ● 314 | Aluminum | 3 1/8" |

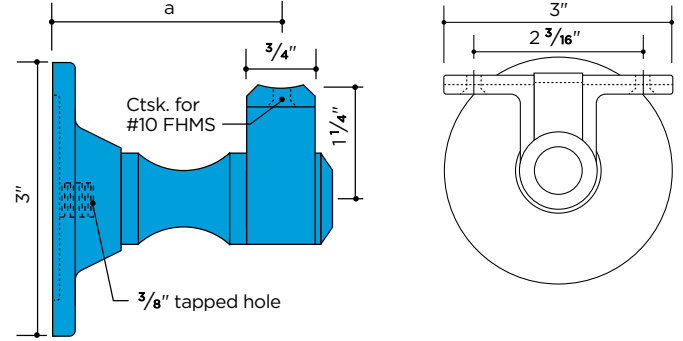

| For use with pipe railings | | a |
|----------------------------|----------|--------|
| ● 307* | Aluminum | 2 1/2" |
| ● 308* | Aluminum | 3" |

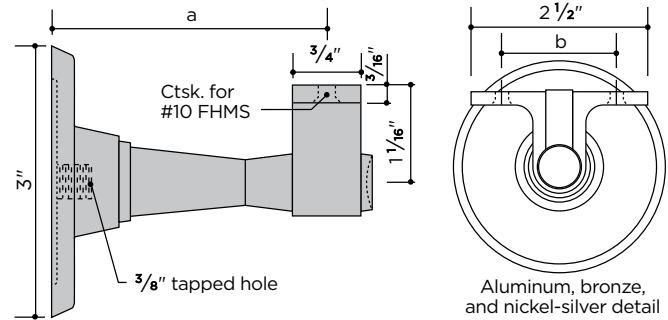

| | a | b | |
|--------|---------------|--------|----------|
| ● 443 | Aluminum | 3" | 1 5/8" |
| ● 444 | Aluminum | 3 1/2" | 1 5/8" |
| ● 844 | Bronze | 2 1/2" | 1 5/8" |
| ● 843 | Bronze | 3" | 1 5/8" |
| ● 1343 | Nickel-Silver | 3" | 1 5/8" |
| ● 271 | Stainless | 2 1/4" | 1 13/16" |
| ● 243 | Stainless | 3" | 1 13/16" |

Aluminum, bronze, and nickel-silver detail

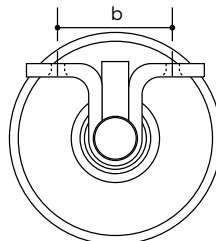

Stainless detail

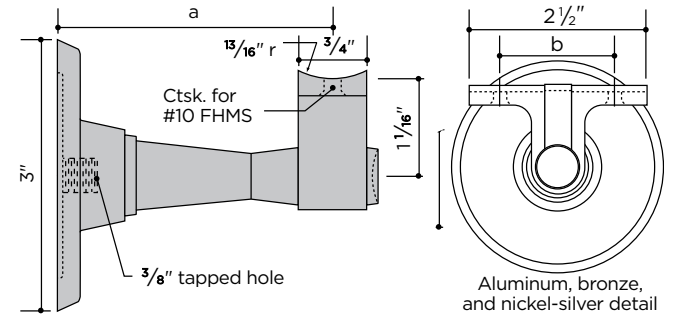

| | a | b | |
|--------|---------------|--------|----------|
| ● 321* | Aluminum | 2 1/4" | 1 5/8" |
| ● 403* | Aluminum | 3" | 1 5/8" |
| ● 405* | Aluminum | 3 1/2" | 1 5/8" |
| ● 842 | Bronze | 2 1/4" | 1 5/8" |
| ● 801 | Bronze | 2 1/2" | 1 5/8" |
| ● 803 | Bronze | 3" | 1 5/8" |
| ● 1342 | Nickel-Silver | 2 1/4" | 1 5/8" |
| ● 1303 | Nickel-Silver | 3" | 1 5/8" |
| ● 242 | Stainless | 2 1/4" | 1 13/16" |
| ● 221 | Stainless | 2 1/2" | 1 13/16" |
| ● 223 | Stainless | 3" | 1 13/16" |

Aluminum, bronze, and nickel-silver detail

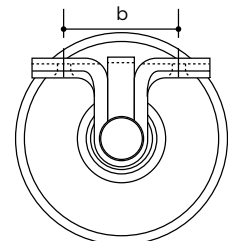

Stainless detail

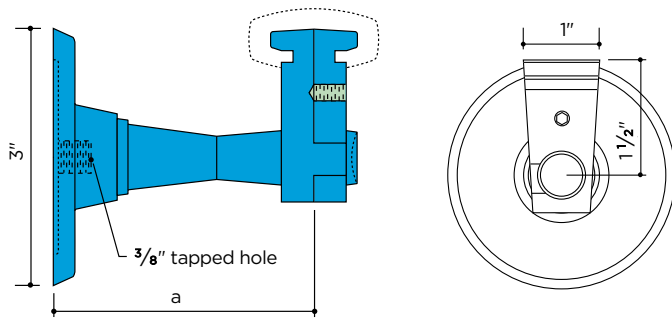

| For use with Carlsrail® handrail moulding | | a |
|-------------------------------------------|----------|--------|
| ● 175 | Aluminum | 2 1/4" |
| ● 173 | Aluminum | 3" |
| ● 174 | Aluminum | 3 1/2" |

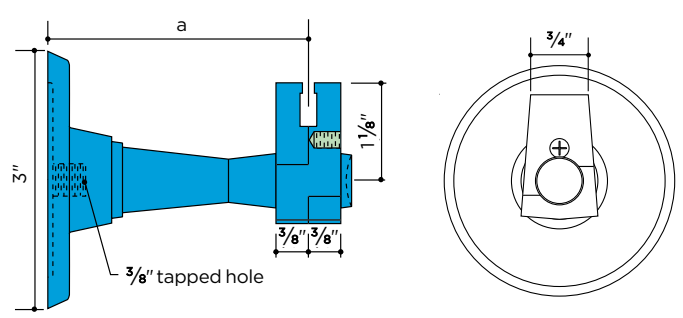

| For use with Carlstadt® T-handrail moulding | | a |
|---------------------------------------------|----------|--------|
| ● 418 | Aluminum | 3" |
| ● 419 | Aluminum | 3 1/2" |

* Also available in clear anodized AA-M32-C22-A31 (204R1) Wall bracket extensions, pg. 94

● ALUMINUM ● BRONZE ● NICKEL-SILVER ● STAINLESS

SELF-ALIGNING

Carlstadt® Post Brackets are supplied with 1/2" stainless steel studs for attachment to metal posts. To mount Carlstadt® Post Brackets onto wood, use the post bracket hanger bolt shown on page 94.

Satin Finish

For use with pipe railings

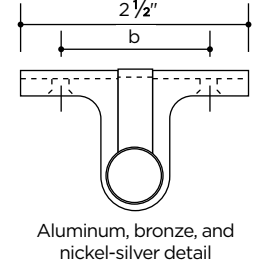
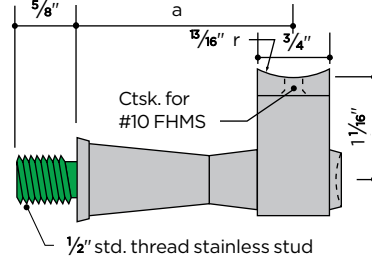
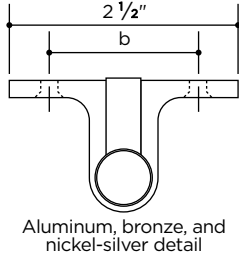
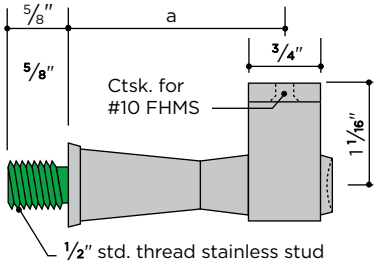

| | a | b |
|----------------------|--------|----------|
| ● 441 Aluminum | 2 1/4" | 1 5/8" |
| ● 442 Aluminum | 2 3/4" | 1 5/8" |
| ● 841 Bronze | 2 1/4" | 1 5/8" |
| ● 1341 Nickel-Silver | 2 1/4" | 1 5/8" |
| ● 241 Stainless | 2 1/4" | 1 13/16" |

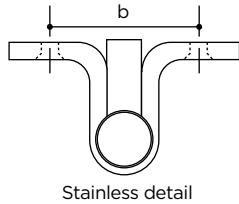

| | a | b |
|----------------------|--------|----------|
| ● 402* Aluminum | 2 1/4" | 1 5/8" |
| ● 402L* Aluminum | 2 1/2" | 1 5/8" |
| ● 404* Aluminum | 2 3/4" | 1 5/8" |
| ● 802 Bronze | 2 1/4" | 1 5/8" |
| ● 1302 Nickel-Silver | 2 1/4" | 1 5/8" |
| ● 222 Stainless | 2 1/4" | 1 13/16" |
| ● 222L Stainless | 2 1/2" | 1 5/8" |

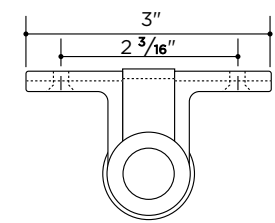
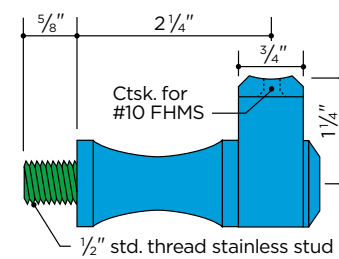
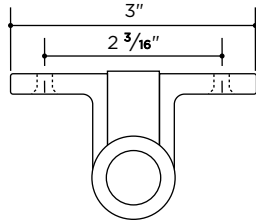
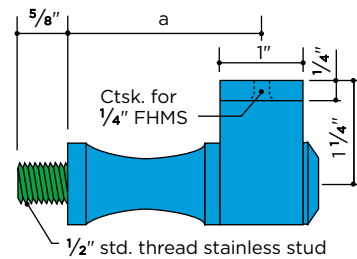
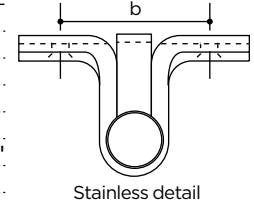

| For use with Carlstadt® handrail moulding | a |
|-------------------------------------------|--------|
| ● 309 Aluminum | 3 1/4" |
| ● 312 Aluminum | 2 3/8" |

● 322* Aluminum

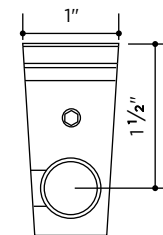
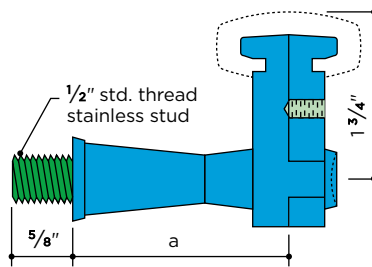
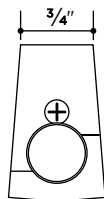
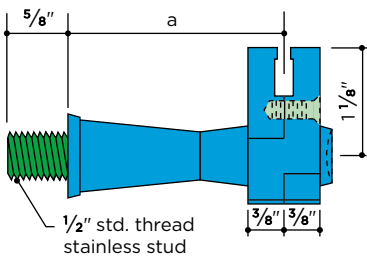

| For use with Carlstadt® T-handrail moulding | a |
|---------------------------------------------|--------|
| ● 439 Aluminum | 2 1/4" |
| ● 440 Aluminum | 2 3/4" |

| For use with Carlsrail® handrail moulding | a |
|-------------------------------------------|--------|
| ● 171 Aluminum | 2 1/4" |
| ● 172 Aluminum | 2 3/4" |

* Also available in clear anodized AA-M32-C22-A31 (204R1) Post bracket extensions, pg. 94

● ALUMINUM ● BRONZE ● NICKEL-SILVER ● STAINLESS ● CAST IRON/MALLEABLE IRON/STEEL

POST BRACKET EXTENSIONS

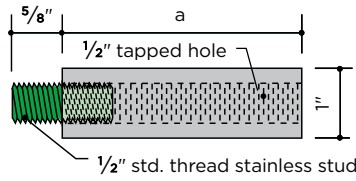

| | a |
|----------------------|-------|
| ● 462* Aluminum | 13/4" |
| ● 463* Aluminum | 3" |
| ● 862 Bronze | 13/4" |
| ● 863 Bronze | 3" |
| ● 1362 Nickel-Silver | 13/4" |
| ● 1366 Nickel-Silver | 3" |
| ● 245 Stainless | 13/4" |
| ● 246 Stainless | 3" |

Extensions may be cut to length to suit individual conditions.

Designers should note that extending a bracket increases stress at its base and reduces its allowable load.

POST BRACKET ADAPTER

Satin Finish

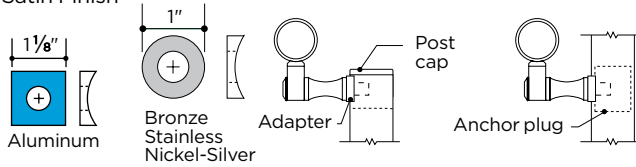

| | Pipe Size | Schedule | Clear Hole |
|-----------------------|-----------|----------|------------|
| ● 7161* Aluminum | 1 1/4" | all | 1/2" |
| ● 7261* Aluminum | 1 1/2" | all | 1/2" |
| ● 8661 Bronze | 1 1/4" | all | 1/2" |
| ● 8861 Bronze | 1 1/2" | all | 1/2" |
| ● 1361 Nickel-Silver | 1 1/2" | all | 1/2" |
| ● 9161 Stainless | 1 1/4" | all | 1/2" |
| ● 9361 Stainless | 1 1/2" | all | 1/2" |
| ● 3164 Malleable Iron | 1 1/2" | all | 1/2" |

Post Bracket Assembly Details

Angle may be adjusted as required.

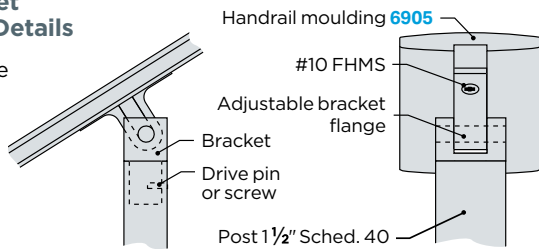

Adjustable Bracket Detail

Post and upper post cap must be drilled and tapped to accept bracket arm. Recess of bracket arm has flat sides to accommodate wrench, which permits tightening without marring exposed surfaces. Handrail flange tilts to adjust to stair angle and is attached to handrail with machine screws. Pressure on tightening block prevents looseness and rattling.

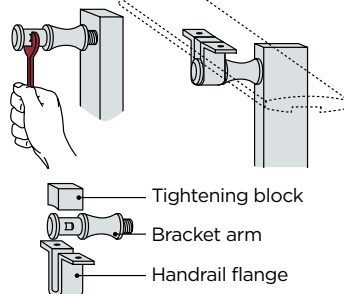

* Also available in clear anodized AA-M10-C22-A31 (204R1)

WALL BRACKET EXTENSIONS

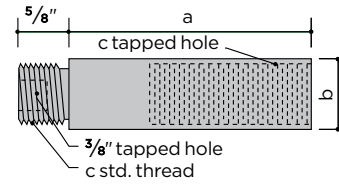

For use with 307, 308, 313, and 314 wall brackets

| | a | b | c |
|-----------------|-------|--------|------|
| ● 414* Aluminum | 13/4" | 1 1/8" | 7/8" |
| ● 415* Aluminum | 3" | 1 1/8" | 7/8" |

For use with Carlstadt® wall brackets

| | a | b | c |
|----------------------|-------|----|------|
| ● 464 Aluminum | 13/4" | 1" | 3/4" |
| ● 465 Aluminum | 3" | 1" | 3/4" |
| ● 864 Bronze | 13/4" | 1" | 3/4" |
| ● 865 Bronze | 3" | 1" | 3/4" |
| ● 1364 Nickel-Silver | 13/4" | 1" | 3/4" |
| ● 1365 Nickel-Silver | 3" | 1" | 3/4" |
| ● 247 Stainless | 13/4" | 1" | 3/4" |
| ● 248 Stainless | 3" | 1" | 3/4" |

Extensions may be cut to length to suit individual conditions but not shorter than 1 1/8".

Extending the reach of a handrail bracket reduces its load-bearing capacity. To compensate for the reduced strength, the number of brackets may be increased and their spacing reduced.

BOLTS AND ANCHORS

For handrail wall brackets

Hanger Bolt



● Steel 3/8" x 3"

Hex Head Lag Screw



- Aluminum 3/8" x 2"
- Brass 3/8" x 2" (Plain or Finished)
- Nickel-Silver 3/8" x 2" (Finished)
- Stainless 3/8" x 2"

Post Bracket Hanger Bolt



● Steel 5/16" x 1 1/2" / 1/2" -13 x 3/8"

Heavy-Duty Double Machine Bolt Anchor (Zinc Alloy)



Non-calking machine bolt anchor for use in masonry materials of questionable strength or where heavy shear loads are encountered. Thread accommodates 3/8" - 16 stud or machine bolt (supplied by others). Drill hole size of 3/4" diameter by 2 1/4" deep.

● ALUMINUM ● STAINLESS

CENTER POST BRACKETS

Center post brackets permit handrail to be centered directly over post, yet allow it to tilt to conform to stair incline. Bracket is secured to post with pin or screw.

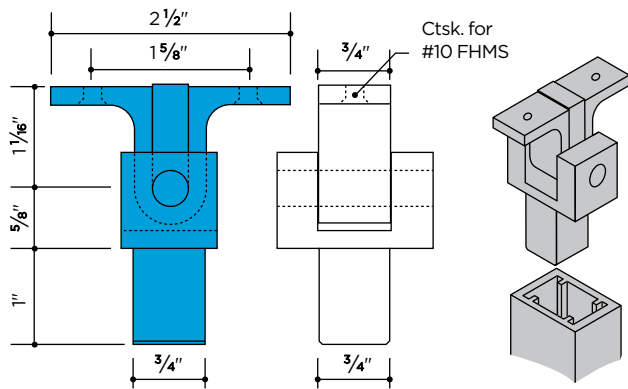

- 161 Aluminum Curved for pipe, fits posts 430 and 6430
- 162 Aluminum Flat for moulding, fits posts 430 and 6430

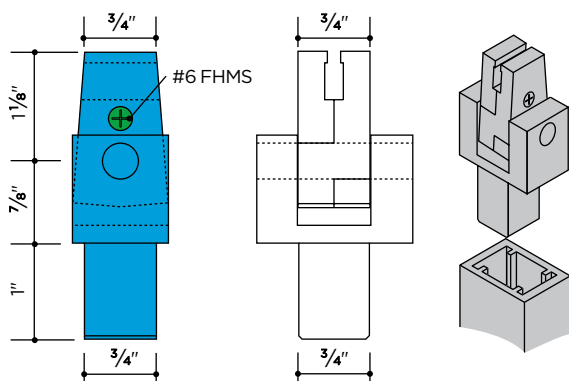

- 152 Aluminum Fits posts 430, 6430, and Carlstadt® T-handrail moulding

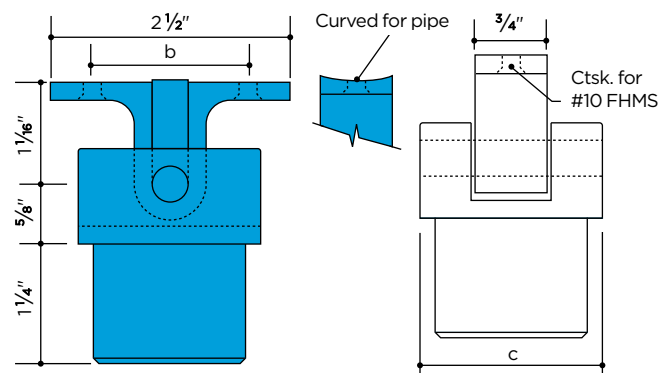

For center mounting of flat-bottomed handrail onto aluminum Connectorail® posts

| Flat | Pipe | Sched. | c | b |
|----------------|--------|--------|--------|--------|
| ● 144 Aluminum | 1 1/4" | 40 | 1.660" | 1 5/8" |
| ● 145 Aluminum | 1 1/2" | 40 | 1.900" | 1 5/8" |

For center mounting of pipe or rounded handrail onto aluminum Connectorail® posts

| Curved | Pipe | Sched. | c | b |
|----------------|--------|--------|--------|--------|
| ● 142 Aluminum | 1 1/4" | 40 | 1.660" | 1 5/8" |
| ● 143 Aluminum | 1 1/2" | 40 | 1.900" | 1 5/8" |

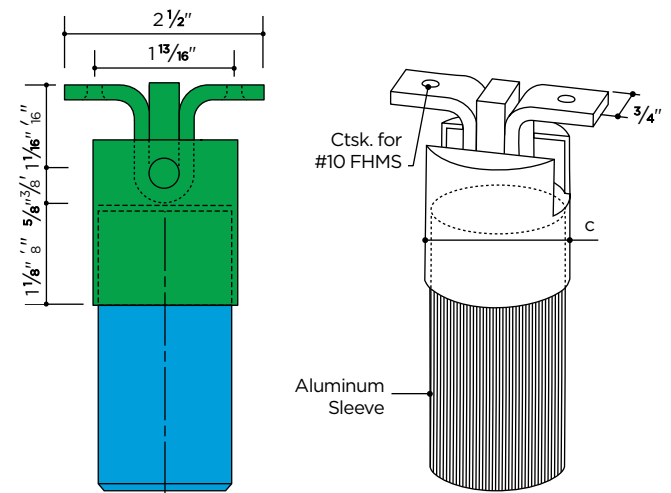

For center mounting of flat-bottomed handrail moulding onto stainless Connectorail® posts

| Flat | Pipe | Sched. | c |
|-----------------------|--------|--------|--------|
| ● 207 Stainless Steel | 1 1/2" | 5 | 1.900" |

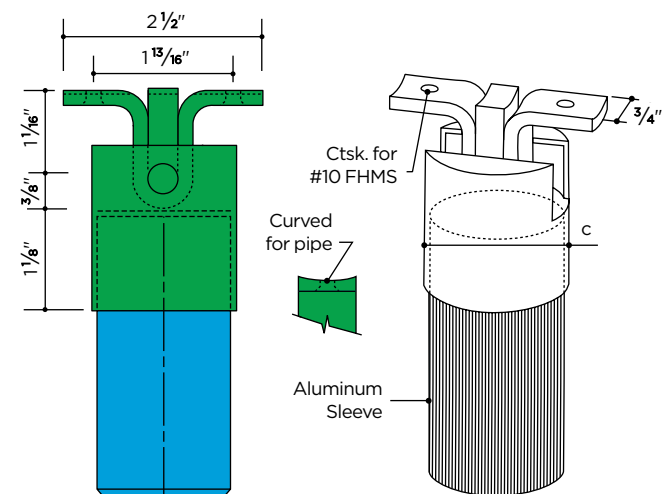

For center mounting of handrail pipe or rounded handrail onto stainless Connectorail® posts

| Curved | Pipe | Sched. | c |
|-----------------------|--------|--------|--------|
| ● 208 Stainless Steel | 1 1/2" | 5 | 1.900" |

● ALUMINUM ● BRONZE ● NICKEL-SILVER ● STAINLESS

GLASS-MOUNTED HANDRAIL

Handrail may be mounted to the face of the tempered glass balustrade using a combination of Carlstadt® wall brackets and our glass mounting adapter kit. The kit contains a disc with a 3/8" stud weld, a bushing, and two gaskets.

To assemble:

1. Prior to tempering, for 1/2" glass drill a 5/8" clear hole; for 3/4" glass drill a 7/8" clear hole.
(Do not attempt to drill a hole in tempered glass – it will most likely break).
2. Insert the bushing into the hole.
3. Insert the stud welded disc with gasket through the bushing; place the gasket on the other side.
4. Thread on bracket and tighten.

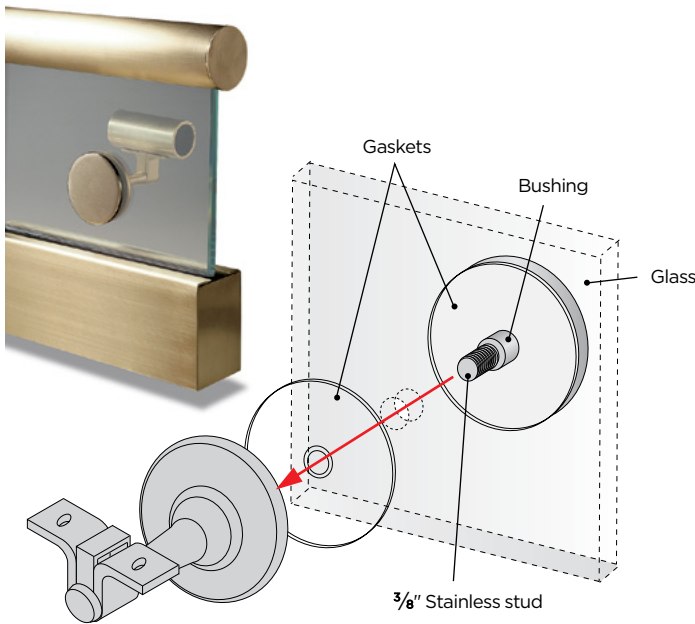

GLASS-MOUNTED HANDRAIL ADAPTER KIT

For 1/2" and 3/4" glass, Satin Finish

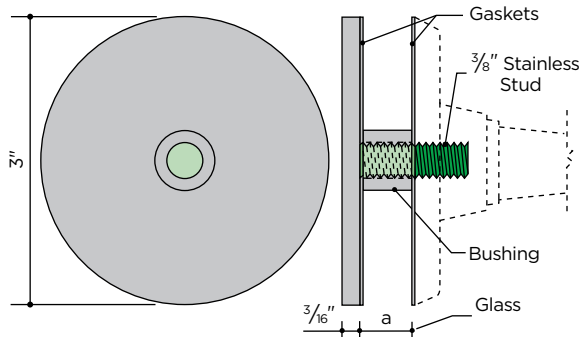

| | | Glass Size | a | Bushing Diameter |
|--------|---------------|------------|------|------------------|
| ● 824 | Bronze | 1/2" | 1/2" | 5/8" |
| ● 840 | Bronze | 3/4" | 3/4" | 7/8" |
| ● 224* | Stainless | 1/2" | 1/2" | 5/8" |
| ● 240* | Stainless | 3/4" | 3/4" | 7/8" |
| ● 1624 | Nickel-Silver | 1/2" | 1/2" | 5/8" |
| ● 1640 | Nickel-Silver | 3/4" | 3/4" | 7/8" |

* For use with aluminum and stainless brackets

THREADED BUSHING BRACKETS

Satin Finish

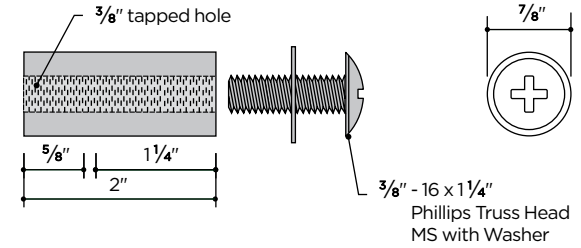

- 163 Aluminum
- 63 Stainless

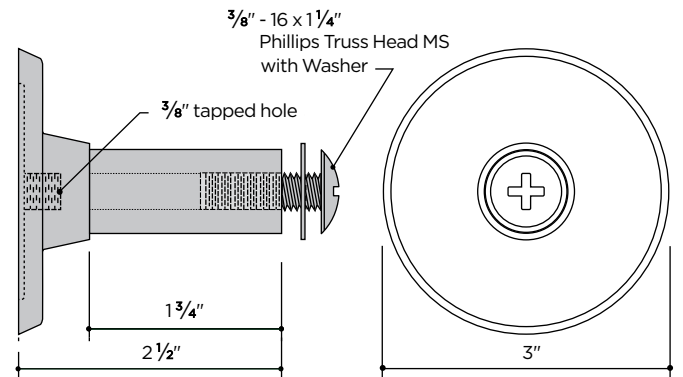

- 164 Aluminum
- 64 Stainless

Installation Details

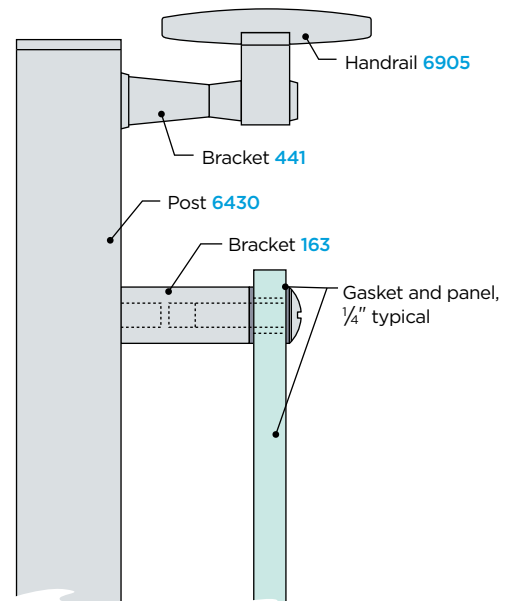

Threaded bushing brackets are used with threaded studs, machine screws, or bolts to install handrails or panels. Brackets may be cut to length as required. Brackets are furnished with aluminum Phillips Truss Head machine screws and washers.

● ALUMINUM ● BRONZE ● NICKEL-SILVER ● STAINLESS

TWO-PIECE MOUNTING BRACKETS

Satin Finish

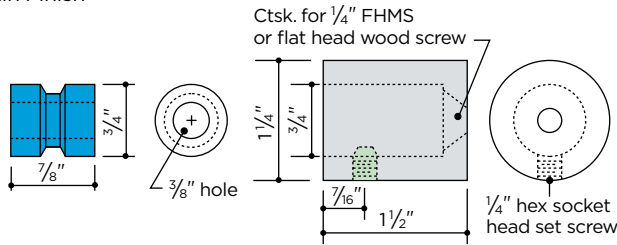

For elevator car handrails

- 166* Aluminum
- 896 Bronze
- 196 Nickel-Silver
- 296 Stainless

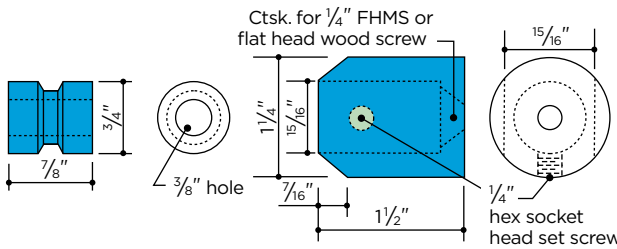

● 167 Aluminum For narrow posts

Versatile two-piece mounting brackets with concealed fasteners are suitable for mounting wall handrails and elevator car rails. 167 is tapered for mounting on a post of 1" or greater width.

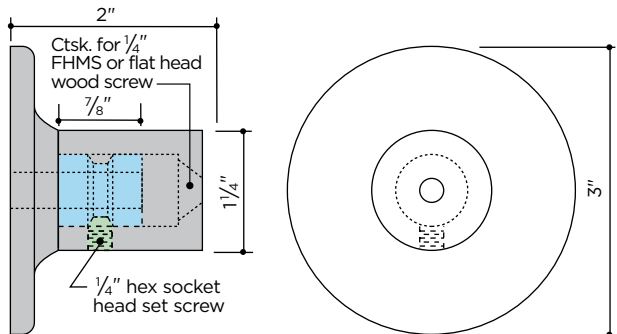

- 168* Aluminum
- 898 Bronze
- 298 Stainless

VERTICAL MOUNTING BRACKET

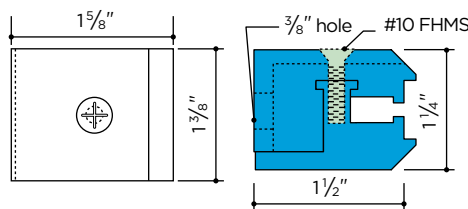

● 151 Aluminum

Vertical mounting bracket 151 is designed for mounting handrail on edge to provide a wall guard or bumper. T-handrail mouldings 6402, 6405, or 6407 can be mounted without drilling and tapping. Bracket is also suitable for mounting handrail on top of a parapet or wall.

TWO-PIECE MOUNTING BRACKETS

Satin Finish

For wide wood handrail

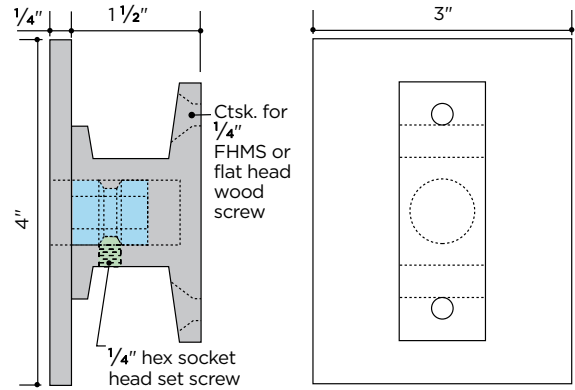

- 160* Aluminum
- 890 Bronze
- 290 Stainless

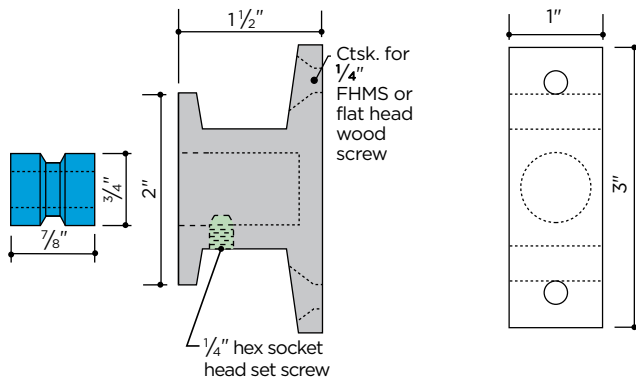

- 169* Aluminum
- 899 Bronze
- 299 Stainless

ADAPTER

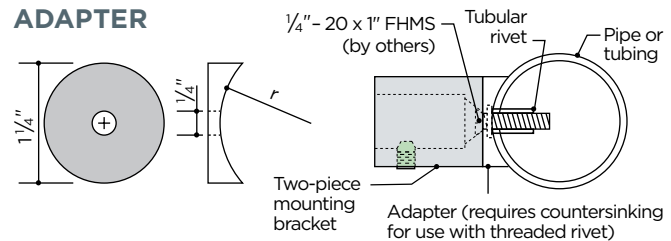

| | r | Use With |
|----------------------|-------|-----------|
| ● 7164* Aluminum | .830" | 1.660" OD |
| ● 7264* Aluminum | .950" | 1.900" OD |
| ● 8864 Bronze | .950" | 1.900" OD |
| ● 8964 Bronze | .750" | 1.500" OD |
| ● 5264 Nickel-Silver | .750" | 1.500" OD |
| ● 5364 Nickel-Silver | .950" | 1.900" OD |
| ● 9164 Stainless | .830" | 1.660" OD |
| ● 9364 Stainless | .950" | 1.900" OD |

* Also available in clear anodized AA-M32-C22-A31 (204R1)

HANDRAIL BRACKETS

ELEVATOR SADDLES THRESHOLDS MOULDINGS



Elevator Cab Interior

This section details our components that are of particular use in the assembly of elevator cabs. Included are Elevator Door Saddles, Flat Fluted Sections, Thresholds and Mouldings, Glass Framing Sections, Door Edgings, and Handrail Mouldings and Brackets suitable for vertical mounting. All brackets are satin finished.

- **Aluminum** components are of alloy 6063; extrusions are T52 temper while machined brackets are T6 temper. When properly fabricated, they are suitable for anodizing, including most of the hard coat anodic processes. Black anodizing may result in inconsistent matches—consult your anodizer before specifying.
- **Bronze** components are of extruded architectural bronze alloy, C38500.
- **Nickel-Silver** saddles, fluted sections, and handrail are extruded from copper-nickel-zinc alloy, C79800.
- **Stainless Steel** components are made of Type 302/304 (18-8) stainless steel.



SADDLES

Elevator and door saddles are available in aluminum, bronze, nickel-silver, stainless steel, and steel. To extend width, flat fluted sections may be combined with single- or double-speed saddles. Saddle alloy matches handrail alloy. Components sold mill finish.



MOULDINGS

A variety of architectural mouldings are available from stock. These mouldings provide for alternate methods of glass framing or door edgings. In restoration work, mouldings are frequently combined.



HANDRAILS AND BRACKETS

Julius Blum & Co., Inc. stocks a large variety of handrail mouldings and brackets for both horizontal and vertical mounting in elevator cabs. Matching elbows and end caps are also available for most sections. Handrail sections are supplied with a smooth mill finish suitable for architectural finishes. All brackets satin finished.



TUBING, BARS, AND SHAPES

A large selection of tubing, bars, and shapes are available from stock in aluminum, bronze, steel, nickel-silver and stainless steel. Refer to pages 106-121. Shapes are extruded to high tolerances and have the sharp corners required for architectural work. Angles and tees are frequently used in dropped ceilings as well as in other areas of elevator cabs.

● ALUMINUM ● BRONZE ● NICKEL-SILVER ● STAINLESS

ELEVATOR DOOR SADDLES

Mill Finish

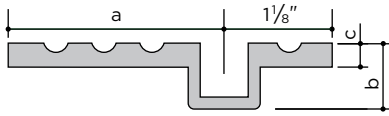

| | | a | b | c | lb/ft | Lengths |
|---------|---------------|--------|---------|------|-------|------------------|
| ● 6963 | Aluminum | 2 1/4" | 1 1/16" | 1/4" | .85 | 20' |
| ● 6969 | Aluminum | 2 7/8" | 1 1/16" | 1/4" | 1.08 | 20' |
| ● 4563 | Bronze | 2 1/4" | 1 1/16" | 1/4" | 2.96 | 6', 8', 10', 16' |
| ● 4569 | Bronze | 2 7/8" | 1 1/16" | 1/4" | 3.93 | 6', 8', 10', 16' |
| ● 5563 | Nickel-Silver | 2 1/4" | 3/4" | 1/4" | 3.58 | 6', 8', 10' |
| ● 5569 | Nickel-Silver | 2 7/8" | 1 1/16" | 1/4" | 4.16 | 6', 8', 10' |
| ● 5569X | Nickel-Silver | 2 7/8" | 1 1/16" | 3/8" | 5.40 | 6', 8' |

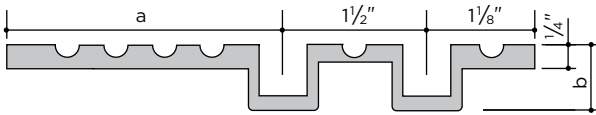

| | | a | b | lb/ft | Lengths |
|--------|---------------|--------|---------|-------|------------------|
| ● 6964 | Aluminum | 2 1/4" | 1 1/16" | 1.25 | 20' |
| ● 6979 | Aluminum | 2 7/8" | 1 1/16" | 1.44 | 20' |
| ● 4564 | Bronze | 2 1/4" | 1 1/16" | 4.25 | 6', 8', 10', 16' |
| ● 4579 | Bronze | 2 7/8" | 1 1/16" | 5.09 | 6', 8', 10', 12' |
| ● 5564 | Nickel-Silver | 2 1/4" | 3/4" | 5.42 | 6', 8', 10' |
| ● 5579 | Nickel-Silver | 2 7/8" | 1 1/16" | 6.35 | 6', 8', 10' |

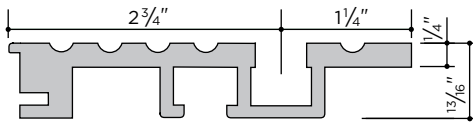

| | | lb/ft | Lengths |
|--------|---------------|-------|---------|
| ● 6989 | Aluminum | 1.54 | 20' |
| ● 4589 | Bronze | 4.79 | 8', 10' |
| ● 5589 | Nickel-Silver | 5.05 | 8', 10' |

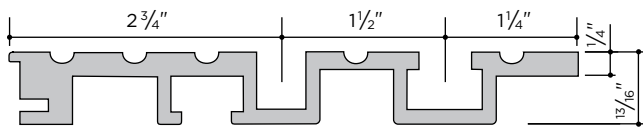

| | | lb/ft | Lengths |
|--------|---------------|-------|---------|
| ● 6999 | Aluminum | 2.10 | 20' |
| ● 4599 | Bronze | 6.55 | 8', 10' |
| ● 5599 | Nickel-Silver | 7.00 | 8', 10' |

EXTENSIONS

20' lengths, Mill Finish

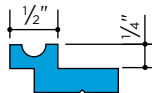

| | | lb/ft |
|--------|----------|-------|
| ● 6967 | Aluminum | .314 |

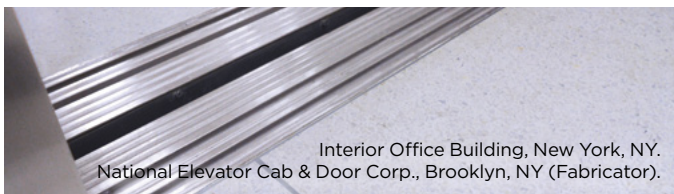

Interior Office Building, New York, NY.
National Elevator Cab & Door Corp., Brooklyn, NY (Fabricator).

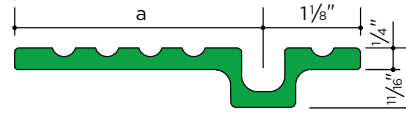

| | | a | lb/ft | Lengths |
|--------|-----------|--------|-------|---------|
| ● 6569 | Stainless | 2 7/8" | 3.71 | 8' |
| ● 6571 | Stainless | 2 1/4" | 3.32 | 8' |

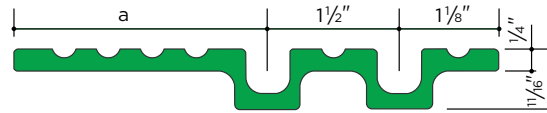

| | | a | lb/ft | Lengths |
|--------|-----------|--------|-------|---------|
| ● 6579 | Stainless | 2 7/8" | 5.53 | 8' |
| ● 6572 | Stainless | 2 1/4" | 5.18 | 8' |

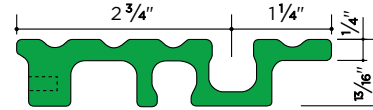

| | | | |
|--------|-----------|------------|------------|
| ● 6589 | Stainless | 5.35 lb/ft | 8' lengths |
|--------|-----------|------------|------------|

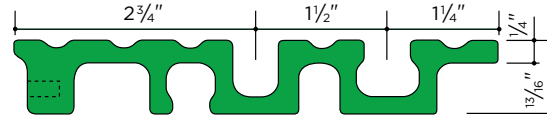

| | | | |
|--------|-----------|------------|------------|
| ● 6599 | Stainless | 7.52 lb/ft | 8' lengths |
|--------|-----------|------------|------------|

FLAT FLUTED SECTIONS

20' lengths, except as noted. For assembled saddles, Mill Finish

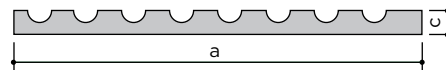

| | | a | c | lb/ft |
|-----------|---------------|--------|------|-------|
| ● 6980*** | Aluminum | 1" | 1/4" | .234 |
| ● 6970 | Aluminum | 1 1/2" | 1/4" | .361 |
| ● 6971 | Aluminum | 2" | 1/4" | .482 |
| ● 6973 | Aluminum | 3" | 1/4" | .723 |
| ● 6975 | Aluminum | 4" | 1/4" | .964 |
| ● 4566 | Bronze | 1" | 1/4" | .720 |
| ● 4558 | Bronze | 1 1/2" | 1/4" | 1.150 |
| ● 4557 | Bronze | 2" | 1/4" | 1.480 |
| ● 4557X* | Bronze | 2" | 3/8" | 2.390 |
| ● 4556 | Bronze | 2 1/2" | 1/4" | 1.840 |
| ● 4555 | Bronze | 3" | 1/4" | 2.230 |
| ● 4554*** | Bronze | 3 1/2" | 1/4" | 2.550 |
| ● 4553 | Bronze | 4" | 1/4" | 2.890 |
| ● 4553Q | Bronze | 4 1/4" | 1/4" | 3.260 |
| ● 4552 | Bronze | 4 1/2" | 1/4" | 3.290 |
| ● 4551 | Bronze | 5" | 1/4" | 3.670 |
| ● 4550* | Bronze | 5 1/2" | 1/4" | 4.050 |
| ● 4559 | Bronze | 6 1/8" | 1/4" | 4.550 |
| ● 5558*** | Nickel-Silver | 1 1/2" | 1/4" | 1.150 |
| ● 5553*** | Nickel-Silver | 4" | 1/4" | 3.040 |
| ● 6573** | Stainless | 2 3/8" | 1/4" | 1.780 |
| ● 6575** | Stainless | 4" | 1/4" | 3.050 |

* 16' lengths ** 8' lengths *** 10' lengths

ELEVATOR SADDLES,
THRESHOLDS, MOULDINGS

● ALUMINUM ● BRONZE ● STEEL

DOOR SADDLES

Mill Finish

FLUTED

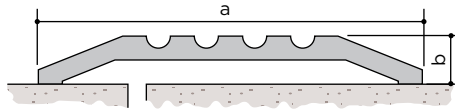

| | | lb/ft | a | b | Lengths |
|--------|----------|-------|----|------|---------|
| ● 6924 | Aluminum | .72 | 3" | 1/2" | 16'-3" |
| ● 6923 | Aluminum | 1.05 | 4" | 1/2" | 20' |
| ● 6926 | Aluminum | .83 | 4" | 1/2" | 16'-3" |
| ● 6922 | Aluminum | 1.27 | 5" | 1/2" | 20' |
| ● 6921 | Aluminum | 1.23 | 6" | 1/2" | 16'-3" |
| ● 6925 | Aluminum | 1.76 | 7" | 1/2" | 20' |
| ● 4524 | Bronze | 2.11 | 3" | 3/8" | 20' |
| ● 4523 | Bronze | 3.05 | 4" | 1/2" | 20' |
| ● 4522 | Bronze | 3.79 | 5" | 1/2" | 20' |
| ● 4520 | Bronze | 4.64 | 6" | 5/8" | 20' |
| ● 4519 | Bronze | 5.14 | 7" | 1/2" | 12' |

SMOOTH

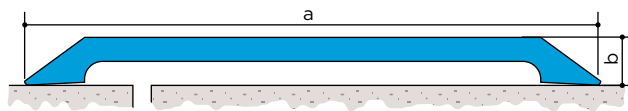

| | | lb/ft | a | b | Lengths |
|--------|----------|-------|--------|------|---------|
| ● 6910 | Aluminum | .365 | 2 1/2" | 1/4" | 20' |
| ● 6914 | Aluminum | .476 | 3" | 1/4" | 16'-3" |

BATHROOM DOOR SADDLES

20' lengths, Mill Finish

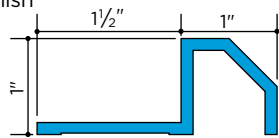

| | | | | | |
|--------|----------|--|--|--|------------|
| ● 6948 | Aluminum | | | | .576 lb/ft |
|--------|----------|--|--|--|------------|

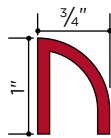

| | | | | | |
|--------|-------|--|--|--|-----------|
| ● 4487 | Steel | | | | .93 lb/ft |
|--------|-------|--|--|--|-----------|

Typical Details

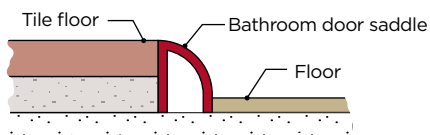
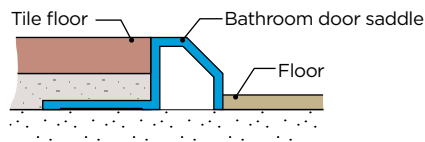

WEATHER STRIP DOOR SADDLES

20' lengths, except as noted, Mill Finish

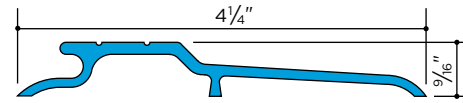

| | | | | | |
|--------|----------|--|--|--|---------------------------|
| ● 6991 | Aluminum | | | | 16'-3" lengths .689 lb/ft |
|--------|----------|--|--|--|---------------------------|

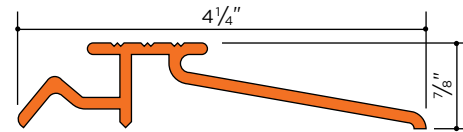

| | | | | | |
|--------|--------|--|--|--|------------|
| ● 4596 | Bronze | | | | 2.21 lb/ft |
|--------|--------|--|--|--|------------|

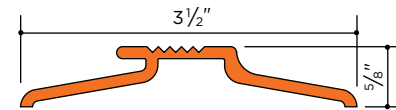

| | | | | | |
|--------|--------|--|--|--|------------|
| ● 4590 | Bronze | | | | 1.92 lb/ft |
|--------|--------|--|--|--|------------|

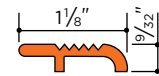

| | | | | | |
|--------|--------|--|--|--|-----------|
| ● 4598 | Bronze | | | | .62 lb/ft |
|--------|--------|--|--|--|-----------|

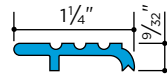

| | | | | | |
|--------|----------|--|--|--|--------------------------|
| ● 6998 | Aluminum | | | | 16'-3" lengths .18 lb/ft |
|--------|----------|--|--|--|--------------------------|

BUTT SADDLE

21'-1" lengths, Mill Finish

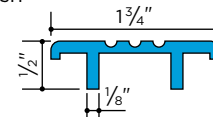

| | | | | | |
|--------|----------|--|--|--|------------|
| ● 6915 | Aluminum | | | | .398 lb/ft |
|--------|----------|--|--|--|------------|

CARPET SADDLE

21'-1" lengths, Mill Finish

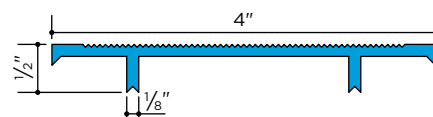

| | | | | | |
|--------|----------|--|--|--|------------|
| ● 6916 | Aluminum | | | | .653 lb/ft |
|--------|----------|--|--|--|------------|

● ALUMINUM ● BRONZE

DOOR SADDLE SECTION

21'- 4" lengths, Mill Finish

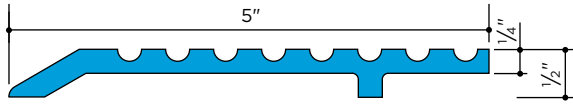

● **6913** Aluminum 1.48 lb/ft

TYPICAL DOOR SADDLE DETAILS

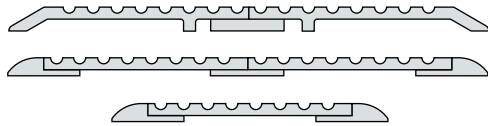

Cutouts for floor hinges can be made easily before assembly.
 Wider saddles can be constructed by adding a flat fluted section in the center. The pattern of all fluted sections is identical, and joints with saddle sections will not be apparent.
 Saddles of extreme width can be constructed by using bevel end sections and two or more flat fluted sections with a plate underneath.

BEVEL END SECTIONS

20' lengths, Mill Finish

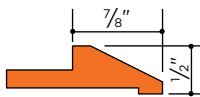

● **4526** Bronze 1.35 lb/ft

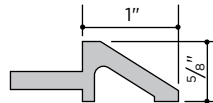

● **6927** Aluminum .45 lb/ft
 ● **4527** Bronze 1.48 lb/ft

NOSINGS

20' lengths, except as noted, Mill Finish

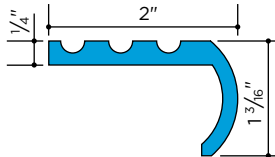

● **6961** Aluminum .722 lb/ft

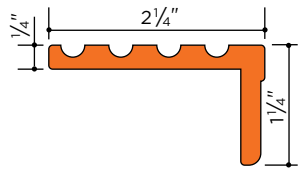

● **4560*** Bronze 2.45 lb/ft
 * 12' lengths

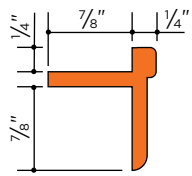

● **4565** Bronze 1.31 lb/ft

ROOF DOOR SADDLE

20' lengths, Mill Finish

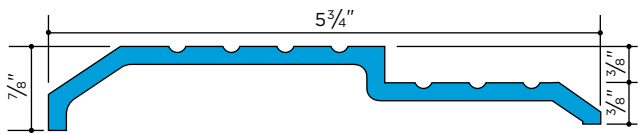

● **6997** Aluminum 1.45 lb/ft

HANDRAIL MOULDINGS

Aluminum 6063-T52, 20' lengths, Mill Finish

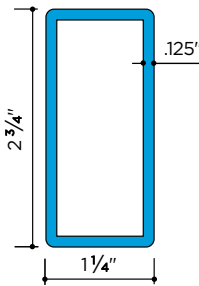

● **6434*** 1.123 lb/ft
 Fittings: end cap

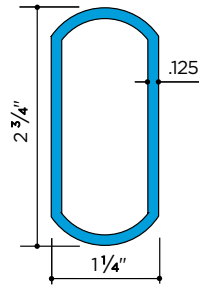

● **6435*** 1.075 lb/ft
 *6063-T6
 Fittings: end cap

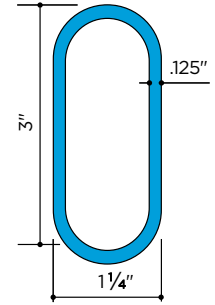

● **6437** 1.057 lb/ft
 Fittings: end cap

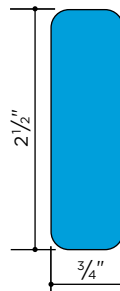

● **6939** 2.214 lb/ft

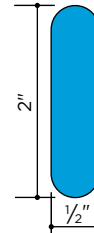

● **6988** 1.138 lb/ft

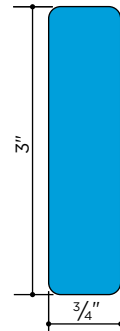

● **6986** 2.684 lb/ft

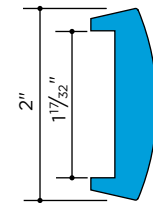

● **6985** .980 lb/ft
 Fittings: end cap

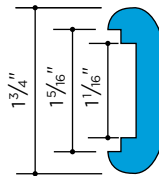

● **6933** .770 lb/ft
 Fittings: end cap

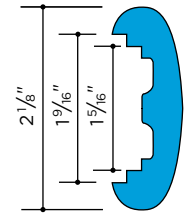

● **6935** .977 lb/ft
 Fittings: end cap

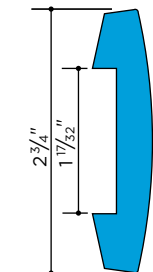

● **6984** 1.301 lb/ft
 Fittings: end cap

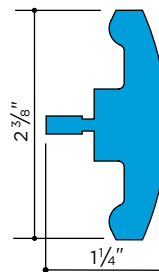

● **6402** 1.510 lb/ft
 Fittings: end cap

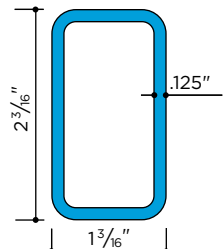

● **6436** .888 lb/ft
 Fittings: end cap

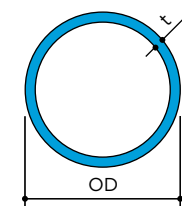

| Pipe size | OD | Sch. | t | lb/ft |
|-----------|-------|------|-------|-------|
| 1 1/4" | 1.66" | 10 | .109" | .625 |
| 1 1/4" | 1.66" | 40 | .140" | .785 |
| 1 1/2" | 1.90" | 10 | .109" | .721 |
| 1 1/2" | 1.90" | 40 | .145" | .940 |

Fittings: end cap

Additional mouldings on pages 34-38

ELEVATOR SADDLES,
 THRESHOLDS, MOULDINGS

● BRONZE ● NICKEL-SILVER ● STAINLESS

HANDRAIL MOULDINGS

Bronze C38500, 20' lengths, except as noted
Mill Finish

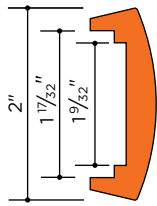

● **4575** 2.37 lb/ft
Fittings: end cap

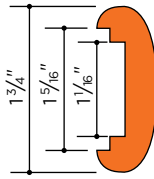

● **4539** 2.66 lb/ft
Fittings: end cap

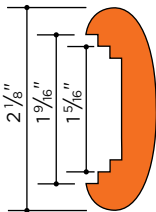

● **4535** 3.35 lb/ft
Fittings: end cap

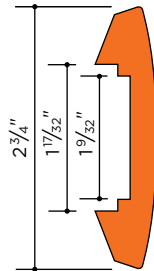

● **4574** 3.71 lb/ft
Fittings: end cap

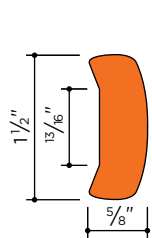

● **4503** Bronze 2.73 lb/ft
No fittings available

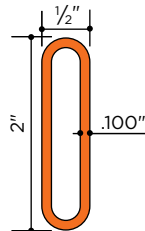

● **6488*** 1.56 lb/ft
Fittings: end cap * 16' lengths

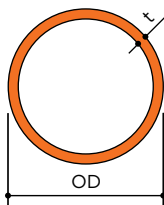

| | OD | t | lb/ft |
|---------------|--------|-------|-------|
| ● 6489 | 1 1/2" | .100" | 1.75 |
| | 1.90" | .100" | 2.07 |

Fittings: end cap, elbow



6488

Nickel-Silver 79800, 20' lengths,
Mill Finish

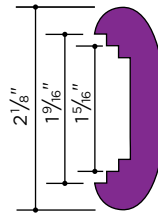

● **5235** 3.16 lb/ft
Fittings: end cap

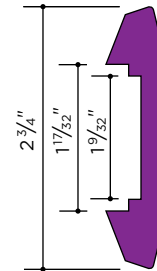

● **5274** 3.71 lb/ft
Fittings: end cap

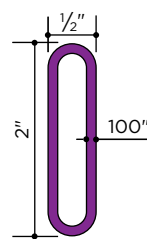

● **5288** 1.56 lb/ft
Fittings: end cap

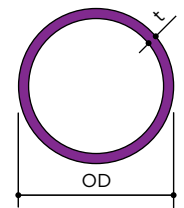

| | OD | t | lb/ft |
|---------------|--------|-------|-------|
| ● 5289 | 1 1/2" | .100" | 1.75 |
| | 1.90" | .109" | 2.25 |

Fittings: end cap

Stainless Type 302/304 (18-8), 20' lengths, except as noted
Mill Finish

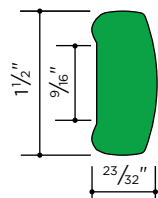

● **6503** 2.54 lb/ft
16' lengths. No fittings available

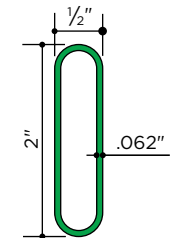

● **4488** .944 lb/ft
Fittings: end cap

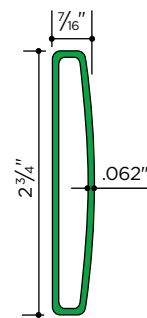

● **6511** 1.25 lb/ft
Fittings: end cap

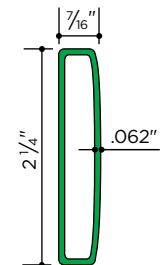

● **6512** 1.00 lb/ft
Fittings: end cap

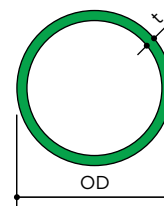

| | Satin Finish | | |
|-----------|--------------|-------|-------|
| Pipe size | OD | t | lb/ft |
| 3/4" | 1.06 | .113" | 1.20 |
| 1" | 1.32 | .120" | 1.46 |
| 1 1/4" | 1.66 | .062" | 1.11 |
| 1 1/4" | 1.66 | .148" | 2.15 |
| 1 1/2" | 1.90 | .062" | 1.27 |
| 1 1/2" | 1.90 | .148" | 2.55 |

Fittings: end cap

Additional mouldings on pages 34-38

● ALUMINUM ● BRONZE ● NICKEL-SILVER ● STAINLESS

TWO-PIECE MOUNTING BRACKETS

Satin Finish

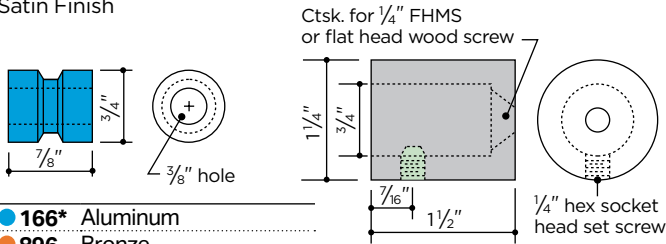

- 166* Aluminum
- 896 Bronze
- 196 Nickel-Silver
- 296 Stainless

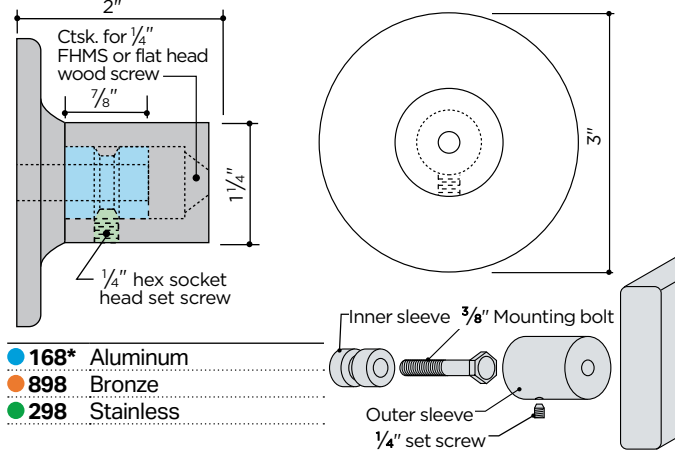

- 168* Aluminum
- 898 Bronze
- 298 Stainless

For wide wood handrails

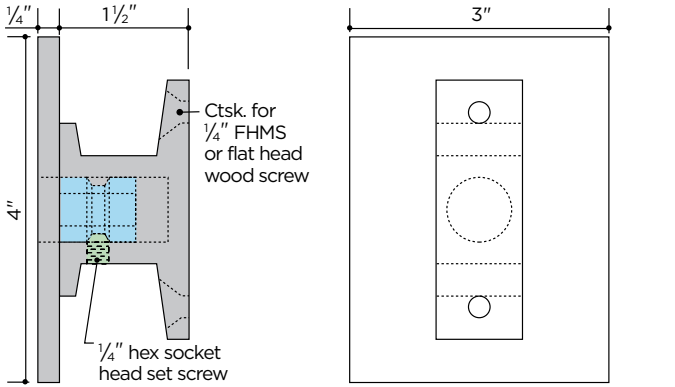

- 160* Aluminum
- 890 Bronze
- 290 Stainless

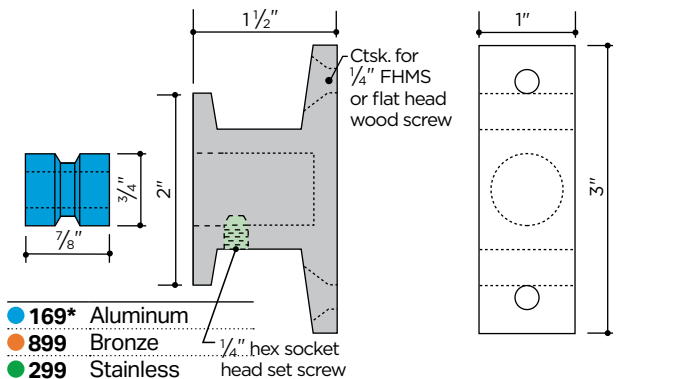

- 169* Aluminum
- 899 Bronze
- 299 Stainless

* Also available in clear anodized AA-M32-C22-A31 (204R1).

THREADED BUSHING BRACKETS

Satin Finish

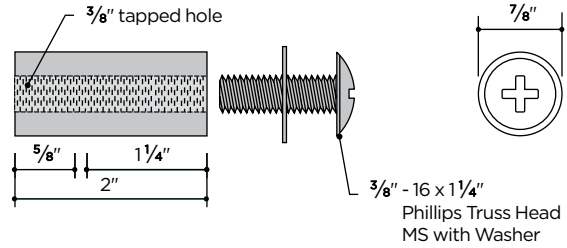

- 163 Aluminum
- 63 Stainless

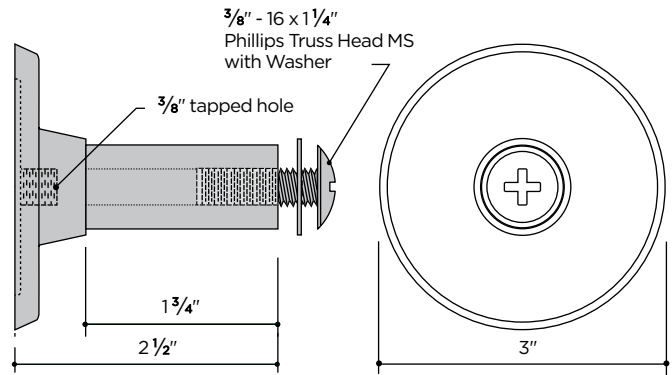

- 164 Aluminum
- 64 Stainless

VERTICAL MOUNTING BRACKET

Satin Finish

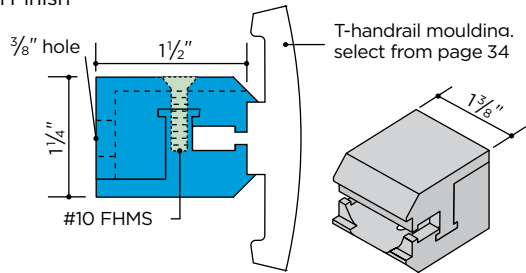

- 151 Aluminum

ADAPTERS

Satin Finish

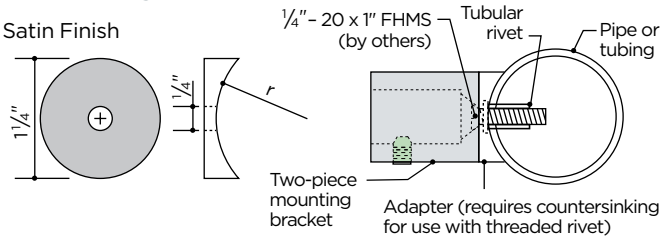

| | r | Use With |
|----------------------|-------|-----------|
| ● 7164* Aluminum | .830" | 1.660" OD |
| ● 7264* Aluminum | .950" | 1.900" OD |
| ● 8864 Bronze | .950" | 1.900" OD |
| ● 8964 Bronze | .750" | 1.500" OD |
| ● 5264 Nickel-Silver | .750" | 1.500" OD |
| ● 5364 Nickel-Silver | .950" | 1.900" OD |
| ● 9364 Stainless | .950" | 1.900" OD |

ELEVATOR SADDLES, THRESHOLDS, MOULDINGS

Full Scale
GLAZING MEMBERS

20' lengths, except as noted

Aluminum and bronze glass stop/snap-in and flexible PVC glazing channel serve to mount panels of 1/4" glass, plastic, wire mesh, or other material.

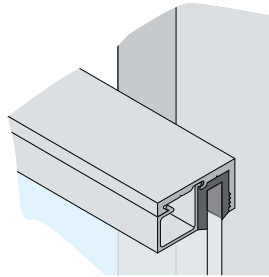

GLASS STOP

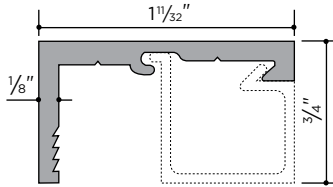

| | lb/ft |
|---------------------------------------------------------------|-------|
| ● 8106 Aluminum Mill Finish | .276 |
| ● 8206 Aluminum Clear Anodized, AA-M10-C22-A31 (204R1) | .276 |
| ● 4506* Bronze | .950 |

* 16' lengths

SNAP-IN

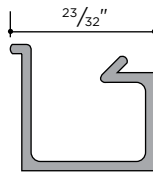

| | lb/ft |
|---------------------------------------------------------------|-------|
| ● 8107 Aluminum Mill Finish | .138 |
| ● 8207 Aluminum Clear Anodized, AA-M10-C22-A31 (204R1) | .138 |
| ● 4507* Bronze | .510 |

* 16' lengths

FLEXIBLE PVC CHANNEL

50' coils

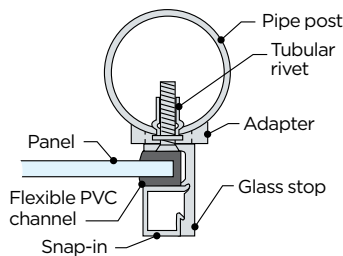
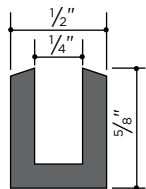

| | |
|----------------------------|--|
| ● 8708 Flexible PVC | |
|----------------------------|--|

COVE MOULDINGS AND GLASS STOPS

20' lengths

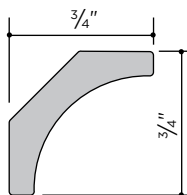
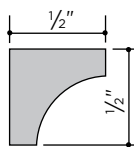

| | lb/ft | | lb/ft |
|------------------------|-------|------------------------|-------|
| ● 6952 Aluminum | .166 | ● 6955 Aluminum | .260 |
| ● 6102 Bronze | .500 | ● 6105 Bronze | .670 |

● ALUMINUM ● BRONZE ● NICKEL-SILVER ● PLASTIC

Full Scale
GLASS FRAMING SECTIONS

20' lengths, except as noted

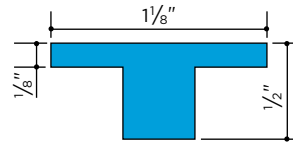

| | |
|------------------------|------------|
| ● 6958 Aluminum | .338 lb/ft |
|------------------------|------------|

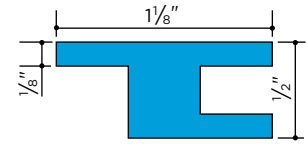

| | |
|------------------------|------------|
| ● 6959 Aluminum | .394 lb/ft |
|------------------------|------------|

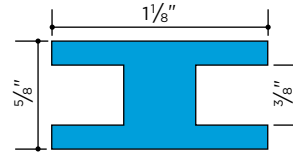

| | |
|------------------------|------------|
| ● 6960 Aluminum | .507 lb/ft |
|------------------------|------------|

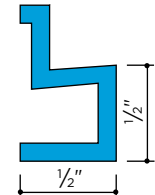

| | |
|-------------------------|------------|
| ● 6953* Aluminum | .183 lb/ft |
|-------------------------|------------|

* 16' lengths

Framing Detail



Sections 6958 and 6959 with flat bars

PANEL CLIPS

For aluminum pipe only

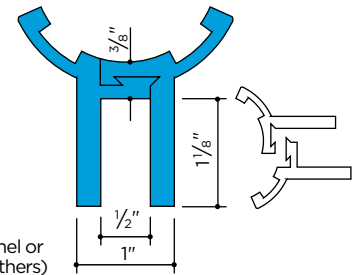
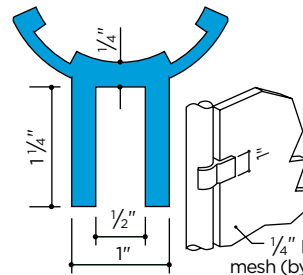

| | Pipe | Packages of 4 sets | Pipe |
|---------------------------|--------|--------------------------|-----------------------|
| ● 7460-5* Aluminum | 1 1/4" | ● 7260** Aluminum | 1 1/2" |
| ● 7460† Aluminum | 1 1/4" | | * 5' Length |
| ● 7560-5* Aluminum | 1 1/2" | | ** Two-piece assembly |
| ● 7560† Aluminum | 1 1/2" | | |

† Packages of 4 pieces

For mounting to flat surface, Satin Finish

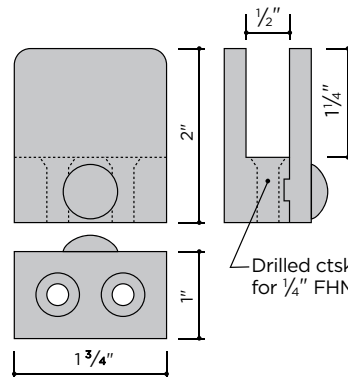

| |
|----------------------------|
| ● 113 Aluminum |
| ● 813 Bronze |
| ● 413 Nickel-Silver |
| ● 213 Stainless |

Drilled ctsk. for 1/4" FHMS

Plug (packed separately) is inserted following installation and may be held in place with epoxy or other sealant. Installation detail page 87.

● ALUMINUM ● BRONZE

DOOR EDGINGS

16' lengths, except as noted. Full Scale

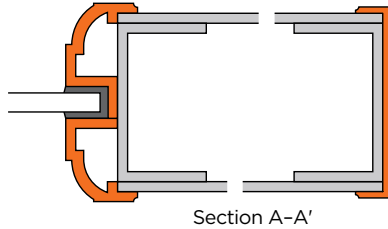
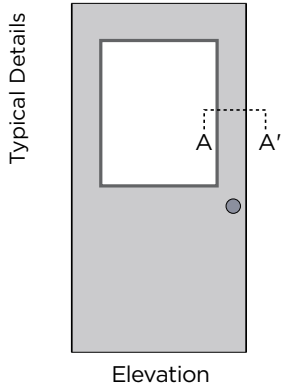

Detail at A-A' with 6643, 6645, and 6646

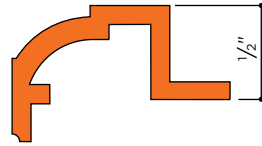

● 6645* Bronze .79 lb/ft

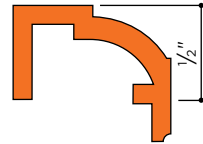

● 6646* Bronze .67 lb/ft

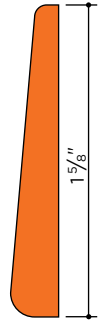

● 6648* Bronze 1.10 lb/ft

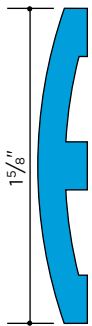

● 6947 Aluminum .384 lb/ft

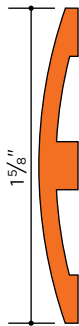

● 6647 Bronze .64 lb/ft

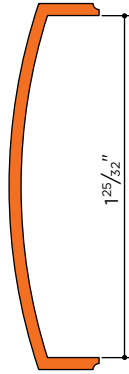

● 6642 Bronze .56 lb/ft

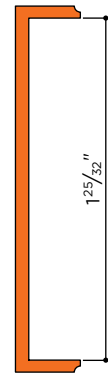

● 6643 Bronze .56 lb/ft

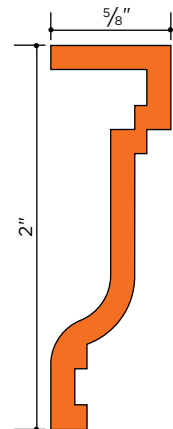

● 6138* Bronze 1.35 lb/ft

* 20' lengths

VARIOUS MOULDINGS

20' lengths

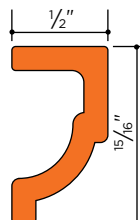

● 6130 Bronze .70 lb/ft

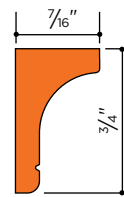

● 6121 Bronze .60 lb/ft

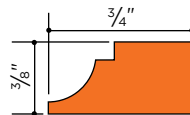

● 6473 Bronze .76 lb/ft

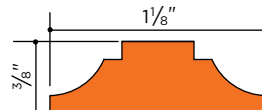

● 6474 Bronze 1.01 lb/ft

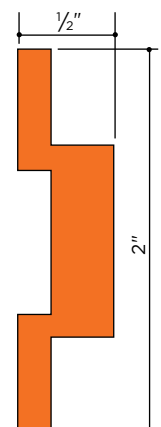

● 6140 Bronze 1.97 lb/ft

ELEVATOR SADDLES,
THRESHOLDS, MOULDINGS

TUBING, BARS, AND SHAPES

Our extensive stock of tubing, bars and shapes in aluminum, bronze, nickel-silver, steel, and stainless steel has been selected especially to meet the requirements of ornamental and miscellaneous metal work.

All items are carried in stock in substantial quantities and shipment is made promptly upon receipt of order. All tubing, bars, and shapes are supplied in stock lengths with a mill finish, except as noted. Julius Blum & Co., Inc. does not provide cutting or metal finishing services.

- **Aluminum** architectural shapes, bars, and tubes are extruded from alloy 6063-T52, except as noted. These items have a smooth, uniform surface and, when properly fabricated, are suitable for anodizing—including most of the hard coat anodic processes. Black anodizing may result in inconsistent matches. Consult your anodizer before specifying. Aluminum extrusions are packed in bundles of approximately

100 lbs., which are wrapped and paper-interleaved at the mill. Ordering in full bundles ensures surface quality and speeds shipping from our warehouse. Aluminum Structural shapes are extruded from alloy 6061-T6.

- **Steel** angles and channels are carbon steel C1010, except as noted. Cold rolled channel and angle have a square root and square edge.
- **Bronze** tubing, bars, and shapes are of extruded alloy C38500, architectural bronze. Round pipe is drawn alloy C23000, red brass. When polished, red brass will provide a generally acceptable match to architectural bronze.
- **Nickel-Silver** shapes are extruded from C79800. Nickel-silver is a copper/nickel alloy and contains no silver. When polished, nickel-silver has the appearance of stainless steel with golden highlights.

- **Stainless Steel** shapes are type 304 (18-8), except as noted. True bars have sharp corners and are not sheared from plate. Stainless steel tubing is of ornamental grade with a smooth surface that is simple to polish.

All extrusions are produced and handled with great care to ensure a product is well suited for architectural finishing. Items are thoroughly protected for shipment by wrapping and/or crating, with the exception of aluminum structural and steel shapes, which are normally shipped in strapped bundles. Elements of sections are shown alongside each item in this section. This data has been ascertained with care but cannot be guaranteed. For additional engineering information, see pages 122 to 129.



Cincinnati Museum Center at Union Terminal, Cincinnati, OH, Savage Metal Restoration, Austerlitz, NY (Fabricator), John G. Waite Associates, Architects PLLC, Albany, NY (Restoration Architect), GBBN, Cincinnati, OH (Architect), © Brad Feinknopf/OTTO (Photo Credit).

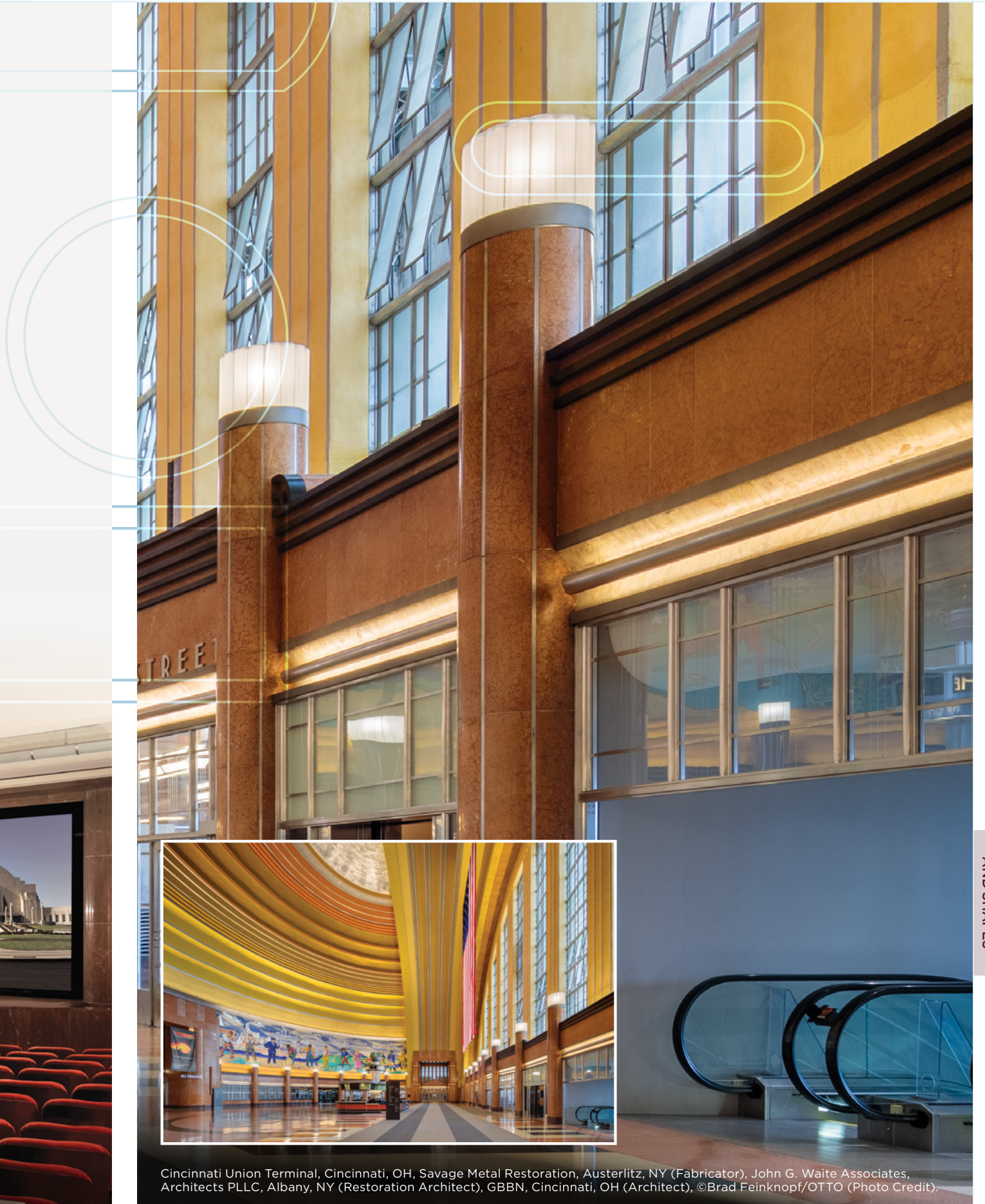

TUBING, BARS,
AND SHAPES

Cincinnati Union Terminal, Cincinnati, OH, Savage Metal Restoration, Austerlitz, NY (Fabricator), John G. Waite Associates, Architects PLLC, Albany, NY (Restoration Architect), GBBN, Cincinnati, OH (Architect), ©Brad Feinknopf/OTTO (Photo Credit).

All dimensions in inches and weight in pounds per lineal foot

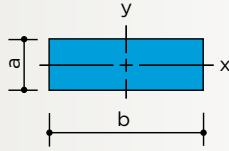
FLAT BARSSharp Corners, Mill Finish,
16' lengths

| a | b | lb/ft | Bars per Bundle† | Area | Ix | Sx | Iy | Sy |
|------|-------|-------|------------------|-------|------|------|-------|-------|
| 1/8 | 1/2 | .075 | 60 | .063 | .000 | .001 | .001 | .005 |
| 1/8 | 5/8 | .094 | 48 | .078 | .000 | .002 | .003 | .008 |
| 1/8 | 3/4 | .113 | 59 | .094 | .000 | .002 | .004 | .012 |
| 1/8 | 1 | .150 | 48 | .125 | .000 | .003 | .010 | .020 |
| 1/8 | 1 1/8 | .169 | 29 | .141 | .000 | .003 | .015 | .026 |
| 1/8 | 1 1/4 | .187 | 29 | .156 | .000 | .003 | .020 | .032 |
| 1/8 | 1 1/2 | .226 | 27 | .188 | .000 | .004 | .035 | .047 |
| 1/8 | 1 3/4 | .263 | 19 | .219 | .000 | .005 | .056 | .064 |
| 1/8 | 2 | .300 | 20 | .250 | .000 | .005 | .083 | .083 |
| 1/8 | 2 1/2 | .376 | 15 | .313 | .000 | .007 | .163 | .130 |
| 1/8 | 3 | .450 | 12 | .375 | .000 | .008 | .281 | .187 |
| 1/8 | 3 1/2 | .526 | 12 | .438 | .001 | .009 | .447 | .255 |
| 1/8 | 4 | .600 | 10 | .500 | .001 | .010 | .667 | .334 |
| 1/8 | 5 | .750 | 8 | .625 | .001 | .013 | 1.302 | .521 |
| 3/16 | 1/2 | .113 | 60 | .094 | .000 | .002 | .002 | .008 |
| 3/16 | 3/4 | .169 | 37 | .141 | .000 | .004 | .007 | .018 |
| 3/16 | 1 | .226 | 30 | .188 | .001 | .006 | .016 | .032 |
| 3/16 | 1 1/4 | .282 | 23 | .235 | .001 | .007 | .031 | .050 |
| 3/16 | 1 1/2 | .337 | 19 | .282 | .001 | .009 | .053 | .071 |
| 3/16 | 1 3/4 | .394 | 16 | .329 | .001 | .010 | .084 | .096 |
| 3/16 | 2 | .450 | 12 | .376 | .001 | .012 | .125 | .125 |
| 3/16 | 2 1/2 | .564 | 12 | .470 | .001 | .015 | .244 | .195 |
| 3/16 | 3 | .677 | 10 | .564 | .002 | .018 | .422 | .281 |
| 3/16 | 4 | .900 | 7 | .752 | .002 | .023 | 1.000 | .500 |
| 1/4 | 1/2 | .150 | 50 | .125 | .001 | .005 | .003 | .010 |
| 1/4 | 5/8 | .187 | 31 | .156 | .001 | .007 | .005 | .016 |
| 1/4 | 3/4 | .224 | 28 | .188 | .001 | .008 | .009 | .023 |
| 1/4 | 1 | .300 | 20 | .250 | .001 | .008 | .021 | .042 |
| 1/4 | 1 1/4 | .374 | 16 | .313 | .002 | .016 | .041 | .066 |
| 1/4 | 1 1/2 | .450 | 12 | .375 | .002 | .016 | .070 | .093 |
| 1/4 | 1 3/4 | .525 | 12 | .438 | .002 | .016 | .112 | .128 |
| 1/4 | 2 | .600 | 10 | .500 | .003 | .024 | .167 | .167 |
| 1/4 | 2 1/2 | .750 | 9 | .625 | .003 | .024 | .326 | .261 |
| 1/4 | 3 | .900 | 7 | .750 | .004 | .032 | .563 | .375 |
| 1/4 | 3 1/2 | 1.050 | 5 | .875 | .005 | .040 | .893 | .510 |
| 1/4 | 4 | 1.200 | 5 | 1.000 | .005 | .040 | 1.333 | .667 |
| 1/4 | 5 | 1.500 | 4 | 1.250 | .007 | .056 | 2.604 | 1.042 |
| 1/4 | 6 | 1.800 | 3 | 1.500 | .008 | .064 | 4.500 | 1.500 |
| 5/16 | 1 | .374 | 20 | .313 | .003 | .019 | .026 | .052 |
| 5/16 | 1 1/2 | .562 | 11 | .469 | .004 | .026 | .088 | .117 |
| 5/16 | 2 | .749 | 8 | .625 | .005 | .032 | .208 | .208 |
| 5/16 | 6 | 2.170 | 3 | 1.875 | .015 | .096 | 5.625 | 1.875 |
| 3/8 | 1/2 | .224 | 24 | .188 | .002 | .012 | .004 | .016 |
| 3/8 | 5/8 | .281 | 20 | .234 | .003 | .015 | .008 | .024 |
| 3/8 | 3/4 | .338 | 15 | .281 | .003 | .018 | .013 | .035 |
| 3/8 | 1 | .450 | 12 | .375 | .004 | .021 | .031 | .062 |
| 3/8 | 1 1/4 | .563 | 10 | .469 | .005 | .027 | .061 | .098 |
| 3/8 | 1 1/2 | .674 | 9 | .563 | .007 | .037 | .106 | .141 |
| 3/8 | 1 3/4 | .784 | 7 | .656 | .008 | .043 | .168 | .192 |
| 3/8 | 2 | .900 | 7 | .750 | .009 | .048 | .250 | .250 |
| 3/8 | 2 1/2 | 1.126 | 5 | .938 | .011 | .059 | .488 | .390 |
| 3/8 | 3 | 1.350 | 4 | 1.125 | .013 | .069 | .844 | .563 |
| 3/8 | 3 1/2 | 1.576 | 4 | 1.313 | .015 | .080 | 1.340 | .767 |
| 3/8 | 4 | 1.800 | 3 | 1.500 | .018 | .096 | 2.000 | 1.000 |
| 3/8 | 5 | 2.260 | 3 | 1.875 | .022 | .177 | 3.906 | 1.563 |
| 1/2 | 3/4 | .450 | 14 | .375 | .008 | .031 | .018 | .047 |
| 1/2 | 1 | .600 | 10 | .500 | .010 | .040 | .042 | .084 |
| 1/2 | 1 1/4 | .750 | 8 | .625 | .013 | .052 | .081 | .130 |
| 1/2 | 1 1/2 | .900 | 6 | .750 | .016 | .064 | .141 | .188 |
| 1/2 | 1 3/4 | 1.050 | 5 | .875 | .018 | .072 | .223 | .255 |

†Aluminum extrusions are pre-wrapped in 100-lb paper-interleaved bundles to speed shipment and prevent damage. Quantities are subject to change without notice.

● ALUMINUM Alloy 6063-T52

All dimensions in inches and weight in pounds per lineal foot

FLAT BARS

(continued)

Sharp Corners, 16' lengths

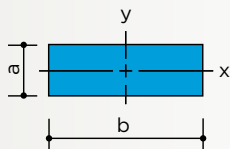

| a | b | lb/ft | Bars per Bundle† | Area | Ix | Sx | Iy | Sy |
|-----|-------|-------|------------------|-------|------|------|-------|-------|
| 1/2 | 2 | 1,200 | 6 | 1.000 | .021 | .084 | .333 | .333 |
| 1/2 | 2 1/2 | 1,500 | 4 | 1.250 | .026 | .104 | .651 | .520 |
| 1/2 | 3 | 1,800 | 3 | 1.500 | .031 | .124 | 1.125 | .750 |
| 1/2 | 3 1/2 | 2,100 | 3 | 1.750 | .036 | .144 | 1.787 | 1.020 |
| 1/2 | 4 | 2,400 | 2 | 2.000 | .042 | .168 | 2.667 | 1.333 |
| 5/8 | 1 | .750 | 8 | .625 | .020 | .064 | .052 | .104 |
| 5/8 | 1 1/4 | .937 | 6 | .781 | .025 | .080 | .102 | .163 |
| 5/8 | 1 1/2 | 1.124 | 5 | .938 | .031 | .099 | .176 | .235 |
| 5/8 | 2 | 1.500 | 4 | 1.250 | .041 | .131 | .417 | .417 |
| 5/8 | 3 | 2.250 | 2 | 1.875 | .061 | .195 | 1.406 | .937 |
| 3/4 | 1 | .900 | 6 | .750 | .035 | .094 | .063 | .125 |
| 3/4 | 1 1/4 | 1.126 | 5 | .938 | .044 | .117 | .122 | .195 |
| 3/4 | 1 1/2 | 1.350 | 5 | 1.125 | .053 | .141 | .210 | .281 |
| 3/4 | 1 3/4 | 1.576 | 4 | 1.313 | .062 | .166 | .335 | .388 |
| 3/4 | 2 | 1.800 | 3 | 1.500 | .070 | .188 | .500 | .500 |
| 3/4 | 2 1/2 | 2.250 | 2 | 1.875 | .088 | .234 | .977 | .781 |
| 3/4 | 3 | 2.700 | 2 | 2.250 | .106 | .281 | 1.688 | 1.125 |
| 3/4 | 3 1/2 | 3.150 | 2 | 2.625 | .123 | .329 | 2.680 | 1.530 |
| 3/4 | 4 | 3.600 | 1 | 3.000 | .141 | .375 | 4.000 | 2.000 |
| 1 | 1 1/4 | 1.500 | 4 | 1.250 | .104 | .208 | .163 | .261 |
| 1 | 1 1/2 | 1.800 | 3 | 1.500 | .125 | .250 | .281 | .375 |
| 1 | 1 3/4 | 2.100 | 3 | 1.750 | .146 | .292 | .447 | .510 |
| 1 | 2 | 2.400 | 2 | 2.000 | .167 | .333 | .667 | .667 |
| 1 | 2 1/2 | 3.000 | 2 | 2.500 | .208 | .417 | 1.302 | 1.042 |
| 1 | 3 | 3.600 | 1 | 3.000 | .250 | .500 | 2.250 | 1.500 |
| 1 | 4 | 4.800 | 1 | 4.000 | .333 | .667 | 5.333 | 2.667 |

SQUARE BARS

Sharp Corners
16' lengths, except
as noted

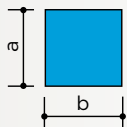

| a | b | lb/ft | Bars per Bundle† | Area | I | S |
|-------|-------|-------|------------------|-------|-------|-------|
| 5/16 | 5/16 | .116 | 48 | .097 | .001 | .005 |
| 3/8 | 3/8 | .169 | 40 | .141 | .002 | .009 |
| 1/2* | 1/2 | .300 | 20 | .250 | .005 | .021 |
| 5/8* | 5/8 | .468 | 12 | .391 | .013 | .041 |
| 3/4 | 3/4 | .674 | 10 | .563 | .026 | .070 |
| 1 | 1 | 1.200 | 5 | 1.000 | .083 | .167 |
| 1 1/4 | 1 1/4 | 1.875 | 3 | 1.563 | .204 | .326 |
| 1 1/2 | 1 1/2 | 2.700 | 2 | 2.250 | .422 | .563 |
| 1 3/4 | 1 3/4 | 3.676 | 1 | 3.063 | .782 | .893 |
| 2 | 2 | 4.800 | 2 | 4.000 | 1.333 | 1.333 |

* 16' & 20' lengths

ROUND BARS

16' lengths, except as noted

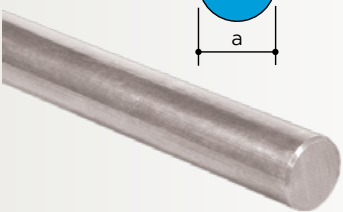
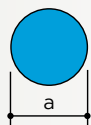

| a | lb/ft | Bars per Bundle† | Area | I | S |
|---------|--------|------------------|--------|--------|-------|
| 3/8 | .132 | 50 | .110 | .001 | .005 |
| 1/2 | .235 | 25 | .196 | .003 | .012 |
| 5/8 | .368 | 18 | .307 | .008 | .024 |
| 3/4 | .530 | 12 | .442 | .016 | .041 |
| 7/8* | .727 | 12 | .601 | .029 | .066 |
| 1* | .942 | 7 | .785 | .049 | .098 |
| 1 1/8* | 1.192 | 7 | .994 | .079 | .140 |
| 1 1/4* | 1.472 | 3 | 1.227 | .120 | .192 |
| 1 1/2 | 2.120 | 3 | 1.767 | .249 | .331 |
| 1.600** | 2.415 | 3 | 2.010 | .322 | .402 |
| 1.625 | 2.740 | - | 2.074 | .342 | .421 |
| 1 3/4 | 2.886 | 3 | 2.404 | .460 | .526 |
| 2* | 3.770 | - | 3.142 | .785 | .785 |
| 2 5/8* | 6.500 | - | 5.412 | 2.331 | 1.030 |
| 3* | 8.483 | - | 7.069 | 3.974 | 2.649 |
| 4** | 15.079 | - | 12.568 | 12.566 | 6.283 |

* 6063-T6 ** 6061-T6 • 12' lengths •• 10' lengths

†Aluminum extrusions are pre-wrapped in 100-lb paper-interleaved bundles to speed shipment and prevent damage. Quantities are subject to change without notice.

TUBING, BARS,
AND SHAPES

All dimensions in inches and weight in pounds per lineal foot

ANGLES

Sharp Corners
16' lengths

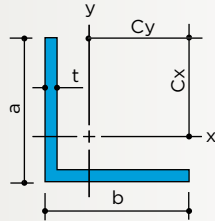

Equal Legs

| a | b | t | lb/ft | Bars per Bundle† | Area | I | S | Cx | Cy |
|-------|-------|------|-------|------------------|-------|-------|------|-------|----|
| 1/2 | 1/2 | 1/16 | .070 | 78 | .058 | .001 | .004 | .352 | |
| 1/2 | 1/2 | 1/8 | .131 | 40 | .109 | .002 | .006 | .330 | |
| 5/8 | 5/8 | 1/8 | .168 | 39 | .141 | .005 | .011 | .424 | |
| 3/4 | 3/4 | 1/16 | .108 | 47 | .089 | .005 | .009 | .540 | |
| 3/4 | 3/4 | 1/8 | .206 | 30 | .172 | .009 | .017 | .517 | |
| 1 | 1 | 1/16 | .145 | 40 | .120 | .012 | .016 | .727 | |
| 1 | 1 | 1/8 | .281 | 20 | .234 | .022 | .031 | .704 | |
| 1 | 1 | 3/16 | .408 | 15 | .341 | .030 | .044 | .682 | |
| 1 1/4 | 1 1/4 | 1/8 | .356 | 15 | .297 | .044 | .049 | .891 | |
| 1 1/4 | 1 1/4 | 3/16 | .519 | 11 | .435 | .062 | .071 | .869 | |
| 1 1/2 | 1 1/2 | 1/8 | .431 | 14 | .359 | .078 | .072 | 1.079 | |
| 1 1/2 | 1 1/2 | 3/16 | .633 | 10 | .529 | .110 | .104 | 1.056 | |
| 1 1/2 | 1 1/2 | 1/4 | .824 | 7 | .688 | .139 | .134 | 1.034 | |
| 1 3/4 | 1 3/4 | 1/8 | .506 | 12 | .422 | .126 | .099 | 1.266 | |
| 2 | 2 | 1/8 | .581 | 11 | .484 | .190 | .131 | 1.454 | |
| 2 | 2 | 3/16 | .857 | 6 | .717 | .273 | .191 | 1.431 | |
| 2 | 2 | 1/4 | 1.124 | 5 | .938 | .348 | .247 | 1.408 | |
| 2 1/2 | 2 1/2 | 1/8 | .731 | 8 | .609 | .378 | .206 | 1.829 | |
| 3 | 3 | 1/8 | .881 | 6 | .734 | .661 | .300 | 2.203 | |
| 3 | 3 | 3/16 | 1.308 | 5 | 1.093 | .964 | .442 | 2.180 | |
| 3 1/2 | 3 1/2 | 1/8 | 1.031 | 6 | .859 | 1.059 | .411 | 2.578 | |
| 4 | 4 | 1/8 | 1.181 | 5 | .984 | 1.591 | .539 | 2.953 | |

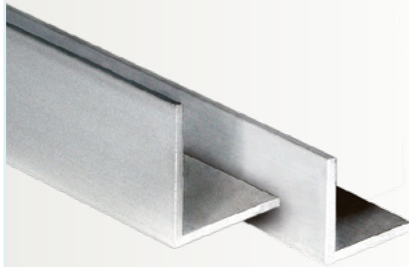

Unequal Legs

| b | a | t | lb/ft | Bars per Bundle† | Area | Ix | Sx | Cx | Iy | Sy | Cy |
|-------|-------|------|-------|------------------|-------|-------|------|-------|-------|------|-------|
| 3/8 | 3/4 | 3/32 | .116 | 60 | .096 | .003 | .007 | .465 | .001 | .001 | .277 |
| 1/2 | 1 | 1/8 | .206 | 29 | .172 | .017 | .027 | .619 | .003 | .008 | .369 |
| 1/2 | 1 1/4 | 1/8 | .244 | 25 | .203 | .032 | .042 | .755 | .003 | .008 | .380 |
| 1/2 | 1 1/2 | 1/8 | .281 | 25 | .234 | .053 | .060 | .888 | .003 | .008 | .388 |
| 1/2 | 2 | 1/8 | .355 | 20 | .297 | .118 | .103 | 1.148 | .003 | .008 | .398 |
| 3/4 | 1 | 1/8 | .244 | 25 | .203 | .020 | .029 | .668 | .009 | .017 | .543 |
| 3/4 | 1 1/2 | 1/8 | .319 | 18 | .266 | .061 | .064 | .952 | .010 | .018 | .577 |
| 3/4 | 2 | 1/8 | .394 | 15 | .328 | .136 | .111 | 1.223 | .011 | .019 | .598 |
| 1 | 1 1/2 | 1/8 | .356 | 15 | .300 | .068 | .068 | 1.003 | .024 | .032 | .753 |
| 1 | 1 3/4 | 1/8 | .394 | 16 | .328 | .104 | .091 | 1.146 | .025 | .033 | .771 |
| 1 | 2 | 1/8 | .431 | 15 | .359 | .150 | .117 | 1.285 | .026 | .033 | .785 |
| 1 | 2 | 3/16 | .633 | 10 | .529 | .215 | .170 | 1.262 | .037 | .048 | .762 |
| 1 | 2 1/2 | 1/8 | .506 | 12 | .422 | .277 | .178 | 1.558 | .028 | .034 | .808 |
| 1 | 3 | 1/8 | .581 | 10 | .484 | .456 | .250 | 1.825 | .029 | .035 | .825 |
| 1 1/4 | 3 1/2 | 1/8 | .694 | 9 | .578 | .750 | .347 | 2.160 | .057 | .055 | 1.035 |
| 1 1/2 | 1 3/4 | 1/8 | .469 | 14 | .391 | .120 | .097 | 1.233 | .081 | .073 | 1.108 |
| 1 1/2 | 2 | 1/8 | .506 | 12 | .422 | .173 | .125 | 1.382 | .085 | .075 | 1.132 |
| 1 1/2 | 2 1/2 | 1/8 | .581 | 10 | .484 | .319 | .191 | 1.671 | .090 | .077 | 1.171 |
| 2 | 2 1/2 | 1/8 | .656 | 10 | .554 | .344 | .194 | 1.779 | .196 | .129 | 1.523 |
| 2 | 3 | 1/8 | .731 | 9 | .609 | .580 | .282 | 2.053 | .213 | .137 | 1.553 |
| 2 | 3 1/2 | 1/8 | .806 | 8 | .672 | .881 | .377 | 2.339 | .222 | .140 | 1.589 |
| 2 | 4 | 1/8 | .881 | 7 | .734 | 1.266 | .483 | 2.618 | .229 | .141 | 1.382 |
| 2 1/4 | 5 1/4 | 1/8 | 1.106 | 6 | .992 | 2.749 | .817 | 3.363 | .340 | .182 | 1.863 |
| 2 1/2 | 3 1/2 | 1/8 | .881 | 7 | .734 | .951 | .391 | 2.432 | .416 | .215 | 1.932 |
| 3 | 3 1/2 | 1/8 | .956 | 6 | .797 | 1.009 | .402 | 2.511 | .692 | .306 | 2.261 |
| 3 | 4 | 1/8 | 1.031 | 6 | .859 | 1.452 | .517 | 2.810 | .719 | .311 | 2.310 |
| 3 | 5 | 1/8 | 1.181 | 5 | .984 | 2.658 | .784 | 3.390 | .762 | .319 | 2.390 |
| 4 | 5 | 1/8 | 1.331 | 5 | 1.109 | 2.924 | .820 | 3.564 | 1.698 | .554 | 3.064 |

†Aluminum extrusions are pre-wrapped in 100-lb paper-interleaved bundles to speed shipment and prevent damage. Quantities are subject to change without notice.

● ALUMINUM Alloy 6063-T52

All dimensions in inches and weight in pounds per lineal foot

TEES

Sharp Corners
16' lengths

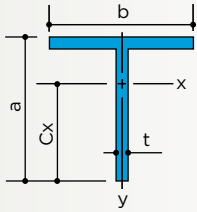

| b | a | t | lb/ft | Bars per Bundle† | Area | Ix | Sx | Cx | Iy | Sy |
|-------|-------|------|-------|------------------|------|------|------|-------|------|------|
| 3/4 | 3/4 | 1/8 | .206 | 30 | .171 | .009 | .017 | .518 | .004 | .012 |
| 3/4 | 1 1/4 | 1/8 | .280 | 20 | .233 | .037 | .045 | .814 | .004 | .012 |
| 1 | 3/4 | 1/8 | .244 | 23 | .202 | .009 | .017 | .544 | .010 | .021 |
| 1 | 1 | 1/8 | .281 | 20 | .233 | .022 | .031 | .705 | .011 | .021 |
| 1 1/8 | 1/2 | 1/8 | .338 | 20 | .282 | .005 | .016 | .318 | .020 | .032 |
| 1 1/8 | 1 1/8 | 1/8 | .319 | 19 | .265 | .031 | .039 | .924 | .015 | .027 |
| 1 1/4 | 7/8 | 1/8 | .300 | 21 | .249 | .016 | .024 | .649 | .020 | .033 |
| 1 1/2 | 1 1/2 | 1/8 | .431 | 12 | .358 | .077 | .072 | 1.080 | .035 | .047 |
| 2 | 3/4 | 1/8 | .394 | 16 | .322 | .010 | .017 | .600 | .083 | .083 |
| 2 | 2 | 3/16 | .856 | 6 | .717 | .271 | .190 | 1.430 | .126 | .126 |

● Item No. 6958 Table 1/8", Leg 3/8"

ZEEES

Sharp Corners
16' lengths

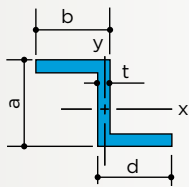

| a | b | d | t | lb/ft | Bars per Bundle† | Area | Ix | Sx | Iy | Sy |
|-----|-------|-------|------|-------|------------------|------|------|------|------|------|
| 1/2 | 1/2 | 1/2 | 3/32 | .148 | 40 | .169 | .004 | .017 | .006 | .016 |
| 3/4 | 3/4 | 3/4 | 1/8 | .300 | 21 | .250 | .020 | .053 | .027 | .039 |
| 7/8 | 3/4 | 3/4 | 1/8 | .319 | 20 | .266 | .029 | .067 | .027 | .039 |
| 1 | 5/8 | 7/8 | 1/8 | .337 | 18 | .281 | .056 | .063 | .015 | .047 |
| 1 | 1 1/8 | 1 1/8 | 1/8 | .450 | 14 | .375 | .058 | .117 | .100 | .094 |

CHANNELS

Sharp Corners
16' lengths, except as noted

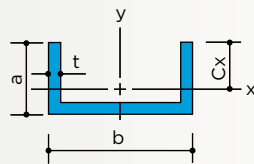

| b | a | t | lb/ft | Bars per Bundle† | Area | Ix | Sx | Cx | Iy | Sy |
|---------|-------|------|-------|------------------|-------|-------|------|-------|-------|-------|
| 1/2 | 3/8 | 1/8 | .150 | 38 | .128 | .002 | .007 | .219 | .004 | .014 |
| 1/2 | 1/2 | 3/32 | .148 | 35 | .126 | .003 | .009 | .348 | .004 | .017 |
| 1/2 | 3/4 | 1/8 | .263 | 22 | .224 | .011 | .027 | .402 | .007 | .028 |
| 5/8 | 5/8 | 1/8 | .244 | 23 | .207 | .007 | .020 | .370 | .011 | .034 |
| 5/8 | 1 | 1/8 | .356 | 16 | .297 | .028 | .050 | .569 | .017 | .053 |
| 3/4 | 3/8 | 1/8 | .187 | 35 | .159 | .002 | .009 | .238 | .011 | .028 |
| 3/4 | 1/2 | 1/8 | .225 | 30 | .191 | .004 | .013 | .323 | .014 | .037 |
| 3/4 | 3/4 | 1/8 | .300 | 20 | .250 | .014 | .030 | .453 | .020 | .053 |
| 1* | 1/2 | 1/8 | .263 | 18 | .219 | .005 | .014 | .330 | .028 | .057 |
| 1 | 5/8 | 1/8 | .304 | 25 | .250 | .009 | .022 | .406 | .035 | .069 |
| 1 | 3/4 | 1/8 | .337 | 20 | .281 | .015 | .031 | .479 | .040 | .081 |
| 1 | 1 | 1/8 | .413 | 12 | .344 | .034 | .055 | .619 | .053 | .105 |
| 1* | 2 | 1/8 | .713 | 8 | .594 | .236 | .200 | 1.148 | .101 | .202 |
| 1 1/4* | 1/2 | 1/8 | .300 | 16 | .250 | .005 | .015 | .344 | .050 | .080 |
| 1 1/4* | 5/8 | 1/8 | .337 | 12 | .281 | .010 | .023 | .424 | .060 | .096 |
| 1 1/4* | 3/4 | 1/8 | .374 | 12 | .312 | .016 | .032 | .500 | .070 | .112 |
| 1 1/4 | 1 1/4 | 1/8 | .526 | 12 | .438 | .069 | .088 | .853 | .110 | .176 |
| 1 1/2* | 1/2 | 1/8 | .337 | 16 | .281 | .005 | .015 | .354 | .080 | .106 |
| 1 1/2* | 5/8 | 1/8 | .374 | 12 | .312 | .010 | .023 | .437 | .094 | .126 |
| 1 1/2 | 3/4 | 1/8 | .413 | 16 | .344 | .017 | .033 | .517 | .109 | .146 |
| 1 1/2 | 1 | 1/8 | .487 | 12 | .406 | .039 | .059 | .668 | .139 | .185 |
| 1 1/2 | 1 1/2 | 1/8 | .637 | 8 | .531 | .123 | .129 | .952 | .198 | .264 |
| 1 3/4 | 1/2 | 1/8 | .374 | 15 | .312 | .005 | .015 | .362 | .118 | .135 |
| 1 3/4 | 3/4 | 1/8 | .450 | 12 | .375 | .018 | .034 | .531 | .159 | .182 |
| 1 3/4 | 1 | 1/8 | .524 | 12 | .438 | .042 | .060 | .688 | .200 | .229 |
| 2 | 1/2 | 1/8 | .413 | 14 | .344 | .006 | .015 | .369 | .166 | .166 |
| 2 | 1 | 1/8 | .564 | 8 | .469 | .043 | .062 | .704 | .276 | .276 |
| 2 | 2 | 1/8 | .863 | 6 | .719 | .301 | .234 | 1.285 | .496 | .496 |
| 2 1/4 | 7/8 | 1/8 | .563 | 11 | .469 | .031 | .048 | .637 | .331 | .294 |
| 2 1/2 | 3/4 | 1/8 | .564 | 10 | .469 | .020 | .036 | .562 | .383 | .307 |
| 2 1/2 | 1 1/2 | 1/8 | .787 | 8 | .656 | .147 | .140 | 1.045 | .648 | .518 |
| 2 1/2 | 2 1/2 | 1/8 | 1.062 | 6 | .906 | .599 | .370 | 1.619 | 1.001 | .801 |
| 3 | 1/2 | 1/8 | .563 | 11 | .469 | .006 | .017 | .387 | .475 | .317 |
| 3 | 1 | 1/8 | .713 | 8 | .594 | .049 | .065 | .753 | .734 | .489 |
| 3 | 2 | 1/8 | .955 | 6 | .844 | .346 | .250 | 1.382 | 1.250 | .834 |
| 3 | 3 | 1/8 | 1.293 | 4 | 1.094 | 1.050 | .538 | 1.952 | 1.767 | 1.178 |
| 4 | 1 1/2 | 1/8 | 1.013 | 6 | .844 | .169 | .150 | 1.132 | 1.960 | .979 |
| 4 1/2 | 1 1/2 | 1/8 | 1.090 | 4 | .906 | .174 | .152 | 1.157 | 2.698 | 1.199 |
| 4 1/2** | 2 | 1/8 | 1.238 | 4 | 1.031 | .394 | .265 | 1.483 | 3.190 | 1.420 |
| 5 | 2 | 3/16 | 1.940 | 2 | 1.621 | .584 | .393 | 1.486 | 5.900 | 2.360 |

* 20' lengths ** For glass block

†Aluminum extrusions are pre-wrapped in 100-lb paper-interleaved bundles to speed shipment and prevent damage. Quantities are subject to change without notice

● ALUMINUM Alloy 6063-T52, except as noted

All dimensions in inches and weight in pounds per lineal foot

ROUND CORNER BARS

20' lengths

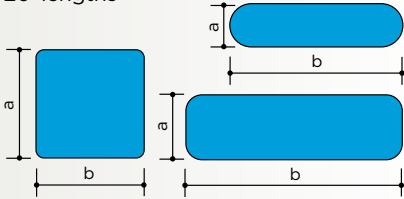

| | | a | b | Corner Radius | lb/ft | Bars per Bundle† | Area | I _x | S _x | I _y | S _y |
|--------|--------|-------|-------|---------------|-------|------------------|-------|----------------|----------------|----------------|----------------|
| ● 6988 | Oval | 1/2 | 2 | 1/4 | 1.138 | 4 | .946 | .019 | .075 | .285 | .285 |
| ● 6939 | Rect. | 3/4 | 2 1/2 | 3/16 | 2.214 | 2 | 1.845 | .085 | .225 | .932 | .746 |
| ● 6986 | Rect. | 3/4 | 3 | 1/8 | 2.684 | 2 | 2.237 | .104 | .277 | 1.658 | 1.106 |
| ● 6423 | Square | 1 1/4 | 1 1/4 | 3/32 | 1.876 | 2 | 1.555 | .201 | .321 | .201 | .321 |
| ● 6424 | Rect. | 1 1/4 | 2 3/4 | 3/32 | 4.124 | 1 | 3.430 | .445 | .712 | 2.153 | 1.566 |

EXTRUDED HANDRAIL PIPE

20' lengths

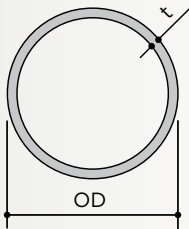

| Nominal Size | Sched. | OD | ID | t | lb/ft | Bars per Bundle† | Area | I | S | r |
|--------------|--------|-------|-------|------|-------|------------------|-------|------|------|------|
| 3/4 | 40 | 1.050 | .824 | .113 | .391 | 14 | .333 | .037 | .071 | .334 |
| 1 | 40 | 1.315 | 1.049 | .133 | .581 | 9 | .494 | .087 | .133 | .421 |
| 1 1/4* | 10 | 1.660 | 1.442 | .109 | .625 | 6 | .531 | .161 | .193 | .550 |
| 1 1/4* | 40 | 1.660 | 1.380 | .140 | .785 | 6 | .669 | .195 | .235 | .540 |
| 1 1/2* | 10 | 1.900 | 1.682 | .109 | .721 | 5 | .614 | .247 | .260 | .634 |
| 1 1/2* | 40 | 1.900 | 1.610 | .145 | .940 | 5 | .800 | .310 | .326 | .623 |
| 2 | 40 | 2.375 | 2.067 | .154 | 1.264 | 3 | 1.075 | .666 | .561 | .787 |

* Carried in stock with mill finish and with a clear anodized – AA-M10-C22-A31 (204R1) – finish.

This pipe is of tubing quality and has a smooth, clean surface and close dimensional tolerances which make it suitable for architectural work and for anodizing. It is easy to bend. Pipe is furnished and carefully wrapped for protection in handling and shipping. See pages 16-31 for stock pipe fittings.

DRAWN HANDRAIL PIPE

Alloy 6063-T832

20' lengths

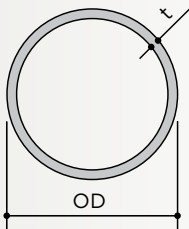

| Nominal Size | Sched. | OD | ID | t | lb/ft | Area | I | S | r |
|--------------|--------|-------|-------|------|-------|------|------|------|------|
| 1 1/4* | 10 | 1.660 | 1.442 | .109 | .625 | .531 | .161 | .193 | .550 |
| 1 1/4* | 40 | 1.660 | 1.380 | .140 | .785 | .669 | .195 | .235 | .540 |
| 1 1/2* | 10 | 1.900 | 1.682 | .109 | .721 | .614 | .247 | .260 | .634 |
| 1 1/2* | 40 | 1.900 | 1.610 | .145 | .940 | .800 | .310 | .326 | .623 |

* Carried in stock with mill finish and with a clear anodized – AA-M10-C22-A31 (204R1) – finish.

This premium quality drawn pipe has an extra smooth surface. Its harder temper gives it high strength. See pages 16-31 for stock pipe fittings.

TUBING

Round Corner

20' lengths

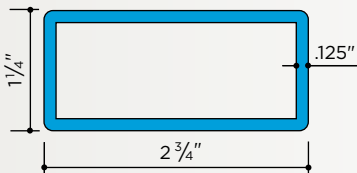

| | | lb/ft | Bars per Bundle† |
|---------|----------|-------|------------------|
| ● 6434* | Aluminum | 1.123 | 5 |

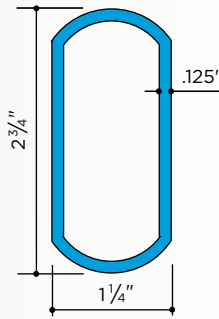

| | | lb/ft | Bars per Bundle† |
|---------|----------|-------|------------------|
| ● 6435* | Aluminum | 1.075 | 5 |

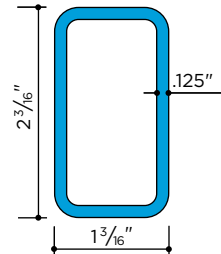

| | | lb/ft | Bars per Bundle† |
|---------|----------|-------|------------------|
| ● 6436* | Aluminum | .888 | 6 |

* 6063-T6 For Elements of Section, see page 123

† Aluminum extrusions are pre-wrapped in 100-lb paper-interleaved bundles to speed shipment and prevent damage. Quantities are subject to change without notice.

● ALUMINUM Alloy 6063-T52

All dimensions in inches and weight in pounds per lineal foot

TUBING

SQUARE

Sharp Corners
21'-1" lengths

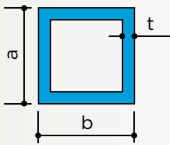

| a | b | t | lb/ft | Bars per Bundle† | Area | I | S |
|-------|-------|------|-------|------------------|-------|-------|-------|
| 1/2 | 1/2 | .062 | .130 | 36 | .109 | .003 | .014 |
| 5/8 | 5/8 | .062 | .167 | 31 | .142 | .007 | .024 |
| 3/4 | 3/4 | .062 | .205 | 24 | .171 | .013 | .036 |
| 3/4 | 3/4 | .125 | .374 | 10 | .312 | .021 | .056 |
| 1 | 1 | .062 | .278 | 16 | .233 | .034 | .068 |
| 1 | 1 | .125 | .525 | 8 | .437 | .057 | .114 |
| 1 1/4 | 1 1/4 | .078 | .438 | 9 | .366 | .084 | .134 |
| 1 1/4 | 1 1/4 | .125 | .675 | 8 | .562 | .120 | .192 |
| 1 1/2 | 1 1/2 | .078 | .532 | 8 | .444 | .150 | .200 |
| 1 1/2 | 1 1/2 | .125 | .825 | 6 | .687 | .218 | .291 |
| 1 3/4 | 1 3/4 | .125 | .975 | 4 | .812 | .360 | .411 |
| 2 | 2 | .078 | .720 | 6 | .600 | .370 | .370 |
| 2 | 2 | .125 | 1.124 | 4 | .937 | .552 | .552 |
| 2 1/2 | 2 1/2 | .125 | 1.424 | 3 | 1.187 | 1.119 | .896 |
| 3 | 3 | .125 | 1.724 | 2 | 1.437 | 1.984 | 1.323 |
| 4 | 4 | .125 | 2.324 | 2 | 1.937 | 4.854 | 2.427 |

RECTANGULAR

Sharp Corners
21'-1" lengths

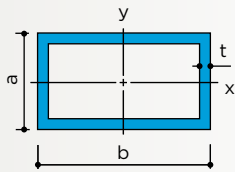

| a | b | t | lb/ft | Bars per Bundle† | Area | Ix | Sx | Iy | Sy |
|-------|-------|------|-------|------------------|-------|-------|-------|--------|-------|
| 1/2 | 1 | .125 | .374 | 12 | .312 | .009 | .003 | .033 | .066 |
| 3/4 | 1 1/2 | .125 | .588 | 8 | .500 | .040 | .106 | .130 | .173 |
| 1 | 1 1/2 | .125 | .661 | 6 | .562 | .081 | .162 | .159 | .212 |
| 1 | 2 | .125 | .825 | 6 | .687 | .105 | .210 | .332 | .332 |
| 1 | 3 | .125 | 1.119 | 4 | .937 | .153 | .307 | .950 | .633 |
| 1 1/4 | 2 1/2 | .125 | 1.050 | 4 | .875 | .219 | .351 | .678 | .543 |
| 1 1/4 | 3 | .125 | 1.200 | 4 | 1.000 | .259 | .415 | 1.079 | .720 |
| 1 1/2 | 2 | .125 | .967 | 4 | .812 | .278 | .370 | .442 | .442 |
| 1 1/2 | 2 1/2 | .125 | 1.124 | 4 | .937 | .337 | .449 | .767 | .613 |
| 1 1/2 | 3 | .125 | 1.276 | 4 | 1.022 | .384 | .512 | 1.167 | .778 |
| 1 1/2 | 6 | .125 | 2.135 | 2 | 1.812 | .752 | 1.002 | 7.197 | 2.399 |
| 1 3/4 | 2 1/4 | .125 | 1.125 | 4 | .937 | .442 | .505 | .661 | .588 |
| 1 3/4 | 3 | .125 | 1.323 | 3 | 1.125 | .566 | .647 | 1.338 | .892 |
| 1 3/4 | 3 1/2 | .125 | 1.470 | 3 | 1.250 | .649 | .742 | 1.962 | 1.121 |
| 1 3/4 | 4 | .125 | 1.650 | 3 | 1.375 | .732 | .836 | 2.742 | 1.371 |
| 1 3/4 | 4 1/2 | .125 | 1.765 | 2 | 1.500 | .814 | .931 | 3.693 | 1.641 |
| 1 3/4 | 5 | .125 | 1.910 | 2 | 1.625 | .897 | 1.025 | 4.833 | 1.933 |
| 2 | 3 | .125 | 1.395 | 3 | 1.187 | .772 | .772 | 1.467 | .978 |
| 2 | 4 | .125 | 1.710 | 3 | 1.438 | .992 | .992 | 2.976 | 1.488 |
| 2 | 5 | .125 | 2.025 | 2 | 1.687 | 1.212 | 1.212 | 5.204 | 2.082 |
| 2 | 6 | .125 | 2.326 | 2 | 1.937 | 1.432 | 1.432 | 8.276 | 2.759 |
| 3 | 5 | .125 | 2.326 | 2 | 1.937 | 3.018 | 2.012 | 6.690 | 2.676 |
| 3 | 6 | .188 | 3.882 | - | 3.226 | 5.010 | 3.340 | 15.032 | 5.010 |



ROUND

20' lengths

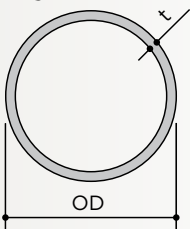

| OD | t | lb/ft | Bars per Bundle† | Area | I | S |
|-------|------|-------|------------------|-------|-------|-------|
| 2 1/2 | .125 | 1.119 | 6 | .933 | .659 | .527 |
| 3 | .125 | 1.330 | 4 | 1.129 | 1.169 | .779 |
| 3 1/2 | .125 | 1.560 | 2 | 1.325 | 1.890 | 1.080 |

See page 129 for fittings

OVAL

20' lengths

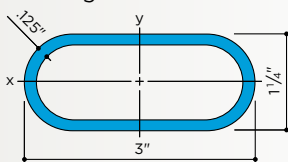

| | lb/ft | Bars per Bundle† | Area | Ix | Sx | Iy | Sy |
|--------|-------|------------------|------|------|------|------|------|
| ● 6437 | 1.057 | 5 | .879 | .210 | .336 | .799 | .532 |

†Aluminum extrusions are pre-wrapped in 100-lb paper-interleaved bundles to speed shipment and prevent damage. Quantities are subject to change without notice.

TUBING, BARS, AND SHAPES

STRUCTURAL TUBING

Aluminum Alloy 6061-T6, 24' lengths

All dimensions in inches and weight in pounds per lineal foot

Square

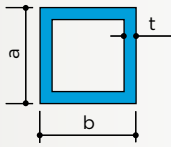

Square

| a | b | t | lb/ft | Area | I | S |
|-------|-------|------|-------|-------|-------|-------|
| 2 | 2 | 1/8 | 1.126 | .937 | .552 | .552 |
| 2 | 2 | 3/16 | 1.627 | 1.343 | .743 | .745 |
| 2 1/2 | 2 1/2 | 3/16 | 2.087 | 1.739 | 1.559 | 1.247 |
| 3 | 3 | 3/16 | 2.538 | 2.115 | 2.798 | 1.865 |
| 4 | 4 | 3/16 | 3.440 | 2.867 | 6.957 | 3.479 |

Rectangular

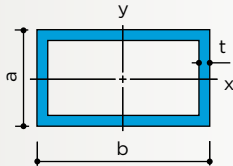

Rectangular

| a | b | t | lb/ft | Area | Ix | Sx | Iy | Sy |
|---|---|------|-------|-------|-------|-------|--------|-------|
| 2 | 3 | 3/16 | 2.123 | 1.739 | 1.064 | 1.064 | 2.055 | 1.370 |
| 2 | 4 | 3/16 | 2.538 | 2.115 | 1.374 | 1.374 | 4.226 | 2.113 |
| 3 | 6 | 3/16 | 3.892 | 3.226 | 5.010 | 3.340 | 15.032 | 5.010 |

● STEEL C1010

COLD-ROLLED ANGLES

Square Root and Square Edge
20' lengths

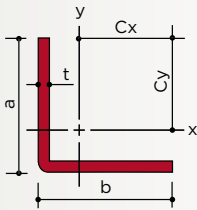

Equal Legs

| a | b | t | lb/ft | Area | I | S | Cx | Cy |
|-------|-------|------|-------|------|------|------|-------|-------|
| 1/2 | 1/2 | 1/8 | .38 | .109 | .002 | .007 | .330 | .330 |
| 5/8 | 5/8 | 1/8 | .48 | .141 | .005 | .011 | .424 | .424 |
| 3/4 | 3/4 | 1/16 | .30 | .089 | .005 | .009 | .539 | .539 |
| 3/4 | 3/4 | 1/8 | .59 | .172 | .009 | .017 | .517 | .517 |
| 1 | 1 | 1/8 | .81 | .234 | .022 | .031 | .704 | .704 |
| 1 | 1 | 3/16 | 1.16 | .341 | .030 | .044 | .682 | .682 |
| 1 1/4 | 1 1/4 | 1/8 | 1.02 | .297 | .044 | .049 | .891 | .891 |
| 1 1/4 | 1 1/4 | 3/16 | 1.48 | .435 | .062 | .071 | .869 | .869 |
| 1 1/2 | 1 1/2 | 1/8 | 1.24 | .359 | .078 | .072 | 1.079 | 1.079 |
| 1 1/2 | 1 1/2 | 3/16 | 1.80 | .529 | .110 | .104 | 1.056 | 1.056 |
| 2 | 2 | 1/8 | 1.65 | .484 | .190 | .131 | 1.454 | 1.454 |
| 2 | 2 | 3/16 | 2.44 | .717 | .273 | .191 | 1.431 | 1.431 |

Unequal Legs

| a | b | t | lb/ft | Area | Ix | Sx | Cx | Iy | Sy | Cy |
|-------|-----|-----|-------|------|------|------|-------|------|------|------|
| 1 | 5/8 | 1/8 | .64 | .187 | .018 | .029 | .646 | .005 | .012 | .163 |
| 1 1/4 | 3/4 | 1/8 | .80 | .234 | .037 | .045 | .812 | .010 | .018 | .562 |
| 1 1/2 | 1 | 1/8 | 1.01 | .297 | .068 | .068 | 1.003 | .024 | .032 | .753 |
| 2 | 1 | 1/8 | 1.23 | .359 | .149 | .116 | 1.285 | .026 | .033 | .785 |

COLD-ROLLED CHANNELS

Square Root and Square Edge
20' lengths, except as noted

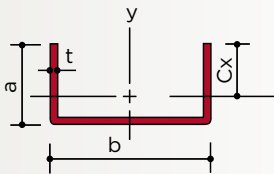

Equal Sides

| | b | a | t | lb/ft | Area | Ix | Sx | Cx | Iy | Sy |
|--------|-------|-------|------|-------|------|------|------|-------|------|------|
| ● 4730 | 1/2 | 1/2 | .093 | .40 | .122 | .003 | .010 | .299 | .004 | .016 |
| ● 4732 | 3/4 | 3/4 | .093 | .57 | .192 | .011 | .023 | .465 | .017 | .044 |
| ● 4734 | 1 | 1 | .109 | 1.03 | .303 | .030 | .049 | .625 | .048 | .096 |
| ● 4744 | 1 1/4 | 1 1/4 | .109 | 1.32 | .385 | .061 | .078 | .792 | .099 | .158 |
| ● 4750 | 1 1/2 | 1 1/2 | .109 | 1.59 | .467 | .109 | .114 | .958 | .178 | .237 |
| ● 4752 | 2 | 2 | .125 | 2.41 | .719 | .309 | .240 | 1.285 | .496 | .496 |

Unequal Sides

| | b | a | t | lb/ft | Area | Ix | Sx | Cx | Iy | Sy |
|---------|-------|--------|------|-------|-------|------|------|-------|-------|-------|
| ● 4735* | 5/8 | 5/16 | .078 | .29 | .085 | .001 | .003 | .206 | .004 | .014 |
| ● 4736* | 3/4 | 3/8 | .083 | .40 | .111 | .001 | .005 | .252 | .008 | .022 |
| ● 4753 | 2 3/8 | 2 3/16 | .156 | 3.41 | 1.005 | .499 | .351 | 1.420 | 1.880 | 1.583 |
| ● 4754 | 1 1/2 | 1 | .109 | 1.22 | .358 | .035 | .052 | .674 | .117 | .155 |
| ● 4759 | 1 3/4 | 1 1/8 | .109 | 1.40 | .412 | .052 | .067 | .768 | .198 | .226 |
| ● 4760 | 2 | 1 | .125 | 1.59 | .469 | .044 | .062 | .704 | .276 | .276 |

* 22' lengths

HOT-ROLLED TEES

20' lengths

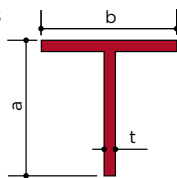

| | a | b | t | lb/ft |
|--------|---|---|-----|-------|
| ● 4724 | 1 | 1 | 1/8 | .90 |

HOT-ROLLED ZEES

Square Root
20' lengths

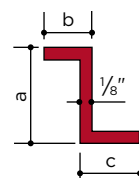

| | a | b | c | lb/ft |
|--------|--------|-----|-----|-------|
| ● 4721 | 1 3/16 | 5/8 | 3/4 | .94 |

● BRONZE Alloy C38500

All dimensions in inches and weight in pounds per lineal foot

ANGLES

Sharp Corners
20' lengths, except as noted

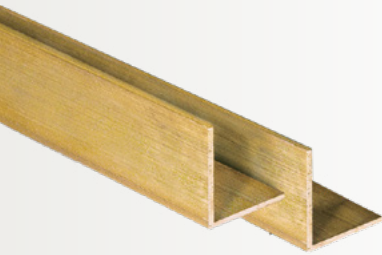
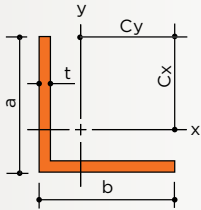

Equal Legs

| a | b | t | lb/ft | Area | Ix | Sx | Cx | Cy |
|-------|-------|------|-------|-------|-------|------|----|-------|
| 1/2 | 1/2 | 1/8 | .42 | .109 | .002 | .006 | | .330 |
| 5/8 | 5/8 | 1/8 | .52 | .141 | .005 | .011 | | .424 |
| 3/4 | 3/4 | 1/8 | .64 | .172 | .009 | .017 | | .517 |
| 1 | 1 | 1/8 | .89 | .234 | .022 | .031 | | .704 |
| 1 | 1 | 3/16 | 1.24 | .341 | .030 | .044 | | .682 |
| 1 1/4 | 1 1/4 | 1/8 | 1.09 | .297 | .044 | .049 | | .891 |
| 1 1/4 | 1 1/4 | 3/16 | 1.60 | .435 | .062 | .071 | | .869 |
| 1 1/4 | 1 1/4 | 1/4 | 2.05 | .562 | .077 | .091 | | .847 |
| 1 1/2 | 1 1/2 | 1/8 | 1.35 | .359 | .078 | .072 | | 1.079 |
| 1 1/2 | 1 1/2 | 3/16 | 1.92 | .529 | .110 | .104 | | 1.056 |
| 1 1/2 | 1 1/2 | 1/4 | 2.52 | .688 | .139 | .134 | | 1.034 |
| 2 | 2 | 1/8 | 1.79 | .484 | .190 | .131 | | 1.454 |
| 2 | 2 | 3/16 | 2.61 | .717 | .273 | .191 | | 1.431 |
| 2 | 2 | 1/4 | 3.37 | .938 | .348 | .247 | | 1.408 |
| 2 1/2 | 2 1/2 | 1/8 | 2.24 | .609 | .378 | .206 | | 1.829 |
| 2 1/2 | 2 1/2 | 1/4 | 4.33 | 1.187 | .703 | .394 | | 1.783 |
| 3* | 3 | 1/4 | 5.25 | 1.437 | 1.244 | .577 | | 2.160 |

* 16' lengths

Unequal Legs

| a | b | t | lb/ft | Area | Ix | Sx | Cx | Iy | Sy | Cy |
|-------|-------|-----|-------|-------|-------|------|-------|------|------|-------|
| 3/4 | 3/8 | 1/8 | .45 | .125 | .007 | .015 | .453 | .001 | .004 | .266 |
| 1 | 1/2 | 1/8 | .65 | .172 | .017 | .027 | .619 | .003 | .008 | .369 |
| 1 | 3/4 | 1/8 | .75 | .203 | .020 | .029 | .668 | .009 | .017 | .543 |
| 1 1/4 | 3/4 | 1/8 | .88 | .234 | .037 | .045 | .812 | .010 | .018 | .562 |
| 1 1/2 | 3/4 | 1/8 | .97 | .266 | .061 | .064 | .952 | .010 | .018 | .577 |
| 1 1/2 | 1 | 1/8 | 1.10 | .300 | .068 | .068 | 1.003 | .024 | .032 | .753 |
| 2 | 1 | 1/8 | 1.33 | .359 | .150 | .117 | 1.285 | .026 | .033 | .785 |
| 3* | 2 | 1/4 | 4.32 | 1.187 | 1.087 | .542 | 2.007 | .392 | .260 | 1.507 |
| 4* | 2 1/2 | 1/4 | 5.70 | 1.562 | 2.602 | .973 | 2.675 | .805 | .418 | 1.925 |

* 16' lengths

CHANNELS

Sharp Corners
20' lengths

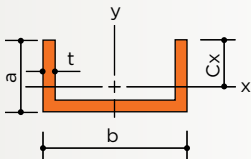

Equal Sides

| b | a | t | lb/ft | Area | Ix | Sx | Cx | Iy | Sy |
|-------|-------|------|-------|------|------|------|------|------|------|
| 1/2 | 1/2 | 3/32 | .44 | .126 | .003 | .009 | .348 | .004 | .017 |
| 3/4 | 3/4 | 1/8 | .90 | .250 | .014 | .030 | .453 | .020 | .053 |
| 1 | 1 | 1/8 | 1.25 | .344 | .034 | .055 | .619 | .053 | .105 |
| 1 1/4 | 1 1/4 | 1/8 | 1.60 | .438 | .069 | .088 | .853 | .110 | .176 |
| 1 1/2 | 1 1/2 | 1/8 | 1.94 | .531 | .123 | .129 | .952 | .198 | .264 |

Unequal Sides

| b | a | t | lb/ft | Area | Ix | Sx | Cx | Iy | Sy |
|-------|------|------|-------|------|------|------|------|------|------|
| 5/8 | 5/16 | 3/32 | .36 | .099 | .001 | .004 | .201 | .005 | .015 |
| 3/4 | 3/8 | 1/8 | .57 | .159 | .002 | .009 | .238 | .011 | .028 |
| 1 | 1/2 | 1/8 | .85 | .219 | .005 | .014 | .330 | .028 | .057 |
| 1 | 3/4 | 1/8 | 1.04 | .281 | .015 | .031 | .479 | .040 | .081 |
| 1 1/4 | 1/2 | 1/8 | .91 | .250 | .005 | .015 | .344 | .050 | .080 |
| 1 1/4 | 5/8 | 1/8 | 1.06 | .281 | .010 | .023 | .424 | .060 | .096 |
| 1 1/2 | 1/2 | 1/8 | 1.02 | .281 | .005 | .015 | .354 | .080 | .106 |
| 1 1/2 | 5/8 | 1/8 | 1.12 | .312 | .010 | .023 | .437 | .094 | .126 |
| 1 1/2 | 1 | 1/8 | 1.47 | .406 | .039 | .059 | .668 | .139 | .185 |
| 2 | 3/4 | 1/8 | 1.47 | .406 | .025 | .039 | .543 | .221 | .221 |
| 2 1/4 | 7/8 | 1/8 | 1.75 | .469 | .031 | .048 | .637 | .331 | .294 |
| 2 1/2 | 1 | 1/8 | 1.94 | .531 | .046 | .064 | .732 | .471 | .377 |

TEES

Sharp Corners
20' lengths

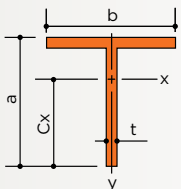

Tees

| b | a | t | lb/ft | Area | Ix | Sx | Cx | Iy | Sy |
|-------|-------|------|-------|------|------|------|-------|------|------|
| 3/4 | 3/4 | 1/8 | .64 | .171 | .009 | .017 | .518 | .004 | .012 |
| 1 | 1 | 1/8 | .89 | .233 | .022 | .031 | .705 | .011 | .021 |
| 1 1/2 | 1 1/2 | 1/8 | 1.35 | .358 | .077 | .072 | 1.080 | .035 | .047 |
| 1 1/2 | 1 1/2 | 3/16 | 1.94 | .529 | .110 | .104 | 1.056 | .054 | .071 |
| 2 | 2 | 3/16 | 2.61 | .717 | .271 | .190 | 1.430 | .126 | .126 |

All dimensions in inches and weight in pounds per lineal foot

FLAT BARS

Sharp Corners
16' lengths, except as noted

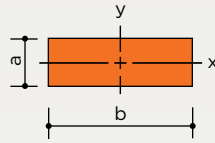

| a | b | lb/ft | Area | I _x | S _x | I _y | S _y |
|-------|-------|-------|-------|----------------|----------------|----------------|----------------|
| 1/8 | 1/2 | .23 | .063 | .000 | .001 | .001 | .005 |
| 1/8 | 5/8 | .29 | .078 | .000 | .002 | .003 | .008 |
| 1/8 | 3/4 | .35 | .094 | .000 | .002 | .004 | .012 |
| 1/8 | 1 | .46 | .125 | .000 | .003 | .010 | .020 |
| 1/8 | 1 1/4 | .58 | .156 | .000 | .003 | .020 | .032 |
| 1/8 | 1 1/2 | .69 | .188 | .000 | .004 | .035 | .047 |
| 1/8 | 2 | .92 | .250 | .000 | .005 | .083 | .083 |
| 1/8 | 3 | 1.38 | .375 | .000 | .008 | .281 | .187 |
| 3/16 | 1/2 | .35 | .094 | .000 | .002 | .002 | .008 |
| 3/16 | 5/8 | .43 | .118 | .000 | .004 | .004 | .012 |
| 3/16 | 3/4 | .52 | .141 | .000 | .004 | .007 | .018 |
| 3/16 | 1 | .69 | .188 | .001 | .006 | .016 | .032 |
| 3/16 | 1 1/2 | 1.04 | .282 | .001 | .009 | .053 | .071 |
| 3/16 | 2 | 1.38 | .376 | .001 | .012 | .125 | .125 |
| 3/16 | 2 1/2 | 1.73 | .470 | .001 | .015 | .244 | .195 |
| 3/16 | 3 | 2.08 | .564 | .002 | .018 | .422 | .281 |
| 3/16 | 3 1/2 | 2.42 | .658 | .002 | .021 | .670 | .383 |
| 3/16 | 4 | 2.76 | .752 | .002 | .023 | 1.000 | .500 |
| 1/4 | 3/8 | .34 | .094 | .000 | .004 | .001 | .006 |
| 1/4 | 1/2 | .46 | .125 | .001 | .005 | .003 | .010 |
| 1/4 | 5/8 | .58 | .156 | .001 | .007 | .005 | .016 |
| 1/4 | 3/4 | .69 | .188 | .001 | .008 | .009 | .023 |
| 1/4 | 1 | .92 | .250 | .001 | .008 | .021 | .042 |
| 1/4 | 1 1/4 | 1.15 | .313 | .002 | .016 | .041 | .066 |
| 1/4 | 1 1/2 | 1.38 | .375 | .002 | .016 | .070 | .093 |
| 1/4 | 2 | 1.84 | .500 | .003 | .024 | .167 | .167 |
| 1/4 | 2 1/2 | 2.30 | .625 | .003 | .024 | .326 | .261 |
| 1/4 | 3 | 2.77 | .750 | .004 | .032 | .563 | .375 |
| 1/4 | 4 | 3.87 | 1.000 | .005 | .040 | 1.333 | .667 |
| 5/16† | 6 | 6.67 | 1.875 | .015 | .096 | 5.625 | 1.875 |
| 3/8 | 1/2 | .68 | .188 | .002 | .012 | .004 | .016 |
| 3/8 | 5/8 | .87 | .234 | .003 | .015 | .008 | .024 |
| 3/8 | 3/4 | 1.04 | .281 | .003 | .018 | .013 | .035 |
| 3/8 | 1 | 1.38 | .375 | .004 | .021 | .031 | .062 |
| 3/8 | 1 1/4 | 1.73 | .469 | .005 | .027 | .061 | .098 |
| 3/8 | 1 1/2 | 2.07 | .563 | .007 | .037 | .106 | .141 |
| 3/8 | 2 | 2.76 | .750 | .009 | .048 | .250 | .250 |
| 3/8 | 2 1/2 | 3.42 | .938 | .011 | .059 | .488 | .390 |
| 3/8 | 3 | 4.11 | 1.125 | .013 | .069 | .844 | .563 |
| 3/8 | 4 | 5.53 | 1.500 | .018 | .096 | 2.000 | 1.000 |
| 1/2 | 3/4 | 1.37 | .375 | .008 | .031 | .018 | .047 |
| 1/2 | 1 | 1.84 | .500 | .010 | .040 | .042 | .084 |
| 1/2 | 1 1/4 | 2.28 | .625 | .013 | .052 | .081 | .130 |
| 1/2 | 1 1/2 | 2.76 | .750 | .016 | .064 | .141 | .188 |
| 1/2 | 1 3/4 | 3.22 | .875 | .018 | .072 | .223 | .225 |
| 1/2 | 2 | 3.68 | 1.000 | .021 | .084 | .333 | .333 |
| 1/2 | 2 1/2 | 4.60 | 1.250 | .026 | .104 | .651 | .520 |
| 1/2 | 3 | 5.48 | 1.500 | .031 | .124 | 1.125 | .750 |
| 1/2 | 4 | 7.36 | 2.000 | .042 | .168 | 2.667 | 1.333 |
| 3/4 | 1 | 2.74 | .750 | .035 | .094 | .063 | .125 |
| 3/4 | 1 1/4 | 3.46 | .940 | .044 | .117 | .122 | .195 |
| 3/4 | 1 1/2 | 4.11 | 1.125 | .053 | .141 | .210 | .281 |
| 3/4 | 2 | 5.53 | 1.500 | .070 | .188 | .500 | .500 |
| 1 | 1 1/4 | 4.56 | 1.250 | .104 | .208 | .163 | .261 |

†8' lengths

ROUND BARS

16' lengths, except as noted

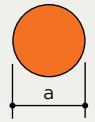

| a | lb/ft | Area | I | S |
|----------|-------|-------|-------|-------|
| 3/8 | .41 | .110 | .001 | .005 |
| 1/2 | .72 | .196 | .003 | .012 |
| 5/8 | 1.13 | .307 | .008 | .024 |
| 3/4 | 1.63 | .442 | .016 | .041 |
| 7/8* | 2.22 | .601 | .029 | .066 |
| 1 | 2.89 | .785 | .049 | .098 |
| 1 1/8 | 3.66 | .994 | .079 | .140 |
| 1 1/4 | 4.52 | 1.227 | .120 | .192 |
| 1 1/2 | 6.51 | 1.767 | .249 | .331 |
| 1 3/4 | 8.86 | 2.405 | .460 | .526 |
| 2* | 11.57 | 3.142 | .785 | .785 |
| 2 1/2 | 18.00 | 4.906 | 1.917 | 1.530 |
| 3** | 26.10 | 7.069 | 3.974 | 2.649 |
| 3 1/2*** | 35.00 | 9.621 | 7.362 | 4.209 |

* 12' lengths ** 10' lengths *** random lengths



SQUARE BARS

Sharp Corners
16' lengths, except as noted

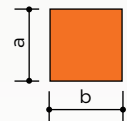

| a | b | lb/ft | Area | I | S |
|---------|-------|-------|-------|-------|-------|
| 1/4 | 1/4 | .23 | .063 | .000 | .003 |
| 3/8 | 3/8 | .52 | .141 | .002 | .009 |
| 1/2 | 1/2 | .92 | .250 | .005 | .021 |
| 5/8 | 5/8 | 1.44 | .391 | .013 | .041 |
| 3/4 | 3/4 | 2.08 | .563 | .026 | .070 |
| 1 | 1 | 3.69 | 1.000 | .083 | .167 |
| 1 1/4 | 1 1/4 | 5.76 | 1.563 | .204 | .326 |
| 1 1/2 | 1 1/2 | 8.28 | 2.250 | .422 | .563 |
| 2 | 2 | 14.76 | 4.000 | 1.333 | 1.333 |
| 2 1/2** | 2 1/2 | 23.06 | 6.250 | 3.255 | 2.604 |

** 10' lengths

● BRONZE Alloy C38500, except as noted

All dimensions in inches and weight in pounds per lineal foot

TUBING

SQUARE
Sharp Corners
16' lengths

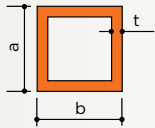

| a | b | t | lb/ft | Area | I | S |
|-------|-------|-------|-------|-------|-------|-------|
| 1/2 | 1/2 | .093 | .56 | .151 | .004 | .018 |
| 5/8 | 5/8 | .093 | .73 | .198 | .010 | .031 |
| 3/4 | 3/4 | .093 | .90 | .244 | .018 | .048 |
| 1 | 1 | .100 | 1.32 | .360 | .049 | .098 |
| 1 1/4 | 1 1/4 | .100 | 1.70 | .460 | .102 | .163 |
| 1 1/2 | 1 1/2 | .100 | 2.07 | .560 | .184 | .245 |
| 1 3/4 | 1 3/4 | .100 | 2.43 | .660 | .300 | .344 |
| 2 | 2 | .125 | 3.46 | .937 | .552 | .552 |
| 2 1/2 | 2 1/2 | .100 | 3.48 | .960 | .923 | .740 |
| 3 | 3 | .125* | 5.27 | 1.437 | 1.984 | 1.323 |

* Rounded inside corners, r = 1/4"

RECTANGULAR
Sharp Corners
16' lengths

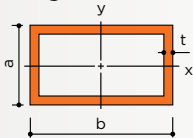

| a | b | t | lb/ft | Area | Ix | Sx | Iy | Sy |
|-------|-------|------|-------|-------|------|------|-------|-------|
| 1/2 | 1 | .100 | .95 | .260 | .009 | .034 | .029 | .058 |
| 3/4 | 1 1/2 | .100 | 1.50 | .410 | .035 | .093 | .110 | .147 |
| 1 | 1 1/2 | .100 | 1.70 | .460 | .070 | .139 | .135 | .180 |
| 1 1/2 | 2 | .100 | 1.70 | .460 | .017 | .068 | .252 | .252 |
| 1 | 2 | .100 | 2.07 | .560 | .090 | .180 | .278 | .278 |
| 1 1/4 | 2 1/2 | .125 | 3.23 | .875 | .219 | .351 | .678 | .543 |
| 1 | 3 | .125 | 3.46 | .937 | .153 | .307 | .950 | .633 |
| 1 1/4 | 3 | .125 | 3.69 | 1.000 | .259 | .415 | 1.071 | .720 |
| 1 1/2 | 3 | .125 | 3.88 | 1.022 | .384 | .512 | 1.167 | .778 |
| 1 3/4 | 3 | .125 | 4.15 | 1.125 | .566 | .647 | 1.338 | .892 |
| 2** | 3 | .125 | 4.48 | 1.187 | .772 | .772 | 1.467 | .978 |
| 1 3/4 | 4 | .125 | 5.28 | 1.375 | .732 | .836 | 2.742 | 1.371 |

**12' lengths

ROUND
20' lengths, except
as noted

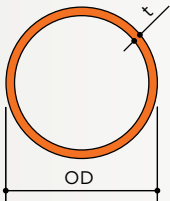

| OD | t | lb/ft | Area | I | S |
|---------|------|-------|-------|-------|-------|
| 1 1/2 ● | .100 | 1.75 | .440 | .108 | .144 |
| 1.900 | .100 | 2.07 | .565 | .230 | .242 |
| 2 1/2 | .125 | 3.44 | .933 | .659 | .527 |
| 3 | .125 | 4.50 | 1.129 | 1.169 | .779 |
| 3 1/2 * | .125 | 4.85 | 1.325 | 1.890 | 1.080 |

● Item No. 6489 *16' lengths

OVAL
16' lengths

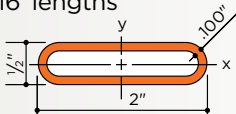

| | lb/ft | Area | Ix | Sx | Iy | Sy |
|---------------|-------|------|------|------|------|------|
| ● 6488 Bronze | 1.56 | .426 | .011 | .044 | .152 | .152 |

HANDRAIL PIPE

Red Brass Alloy C23000
Standard Pipe Sizes, 20' lengths

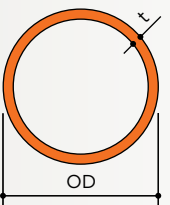

| Nominal Pipe Size | Sched. | OD | ID | t | lb/ft | Area | I | S | r |
|-------------------|--------|-------|-------|------|-------|------|------|------|------|
| 1 1/4 | 40 | 1.660 | 1.368 | .146 | 2.63 | .695 | .201 | .242 | .538 |
| 1 1/2 | 40 | 1.900 | 1.600 | .150 | 3.13 | .825 | .318 | .335 | .621 |

This pipe is furnished with plain ends, unmarked, and with a smooth finish suitable for polishing. See pages 16-27 for stock pipe fittings.

All dimensions in inches and weight in pounds per lineal foot

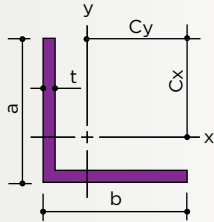
ANGLESSharp Corners
20' lengths

Equal Legs

| a | b | t | lb/ft | Area | I | S | Cx | Cy |
|-------|-------|-----|-------|------|------|------|----|-------|
| 3/4 | 3/4 | 1/8 | .45 | .125 | .007 | .015 | | .453 |
| 1 | 1 | 1/8 | .89 | .234 | .022 | .031 | | .704 |
| 1 1/2 | 1 1/2 | 1/8 | 1.35 | .359 | .078 | .072 | | 1.079 |
| 1 1/2 | 1 1/2 | 1/4 | 2.52 | .688 | .139 | .134 | | 1.034 |

Unequal Legs

| a | b | t | lb/ft | Area | Ix | Sx | Cx | Iy | Sy | Cy |
|---|---|-----|-------|------|------|------|-------|------|------|------|
| 2 | 1 | 1/8 | 1.33 | .359 | .150 | .117 | 1.285 | .026 | .033 | .785 |

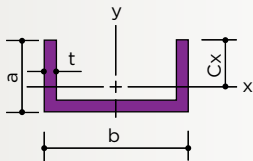
CHANNELSSharp Corners
20' lengths

| b | a | t | lb/ft | Area | Ix | Sx | Cx | Iy | Sy |
|-------|-------|------|-------|------|------|------|------|------|------|
| 1/2 | 1/2 | 3/32 | .44 | .126 | .003 | .009 | .348 | .004 | .017 |
| 3/4 | 3/4 | 1/8 | .90 | .250 | .014 | .030 | .453 | .020 | .053 |
| 1 1/4 | 1 1/2 | 1/8 | .91 | .250 | .005 | .015 | .344 | .050 | .080 |
| 1 1/2 | 1 1/2 | 1/8 | 1.02 | .281 | .005 | .015 | .354 | .080 | .106 |

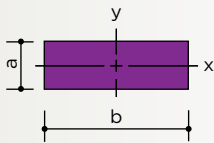
FLAT BARSSharp Corners
16' lengths, except as noted

| a | b | lb/ft | Area | Ix | Sx | Iy | Sy |
|-------|-------|-------|-------|------|------|-------|-------|
| 1/8 | 1 1/4 | .58 | .156 | .000 | .003 | .020 | .032 |
| 1/8 | 1 1/2 | .69 | .188 | .000 | .004 | .035 | .047 |
| 1/4 | 3/4 | .69 | .188 | .001 | .008 | .009 | .023 |
| 1/4 | 1 | .92 | .250 | .001 | .008 | .021 | .042 |
| 1/4 | 1 1/4 | 1.15 | .313 | .002 | .016 | .041 | .066 |
| 1/4 | 2 | 1.84 | .500 | .003 | .024 | .167 | .167 |
| 1/4 | 3 | 2.77 | .750 | .004 | .032 | .563 | .375 |
| 3/8 | 3/4 | 1.04 | .281 | .003 | .018 | .013 | .035 |
| 3/8 | 1 | 1.38 | .375 | .004 | .021 | .031 | .062 |
| 3/8 | 1 1/4 | 1.73 | .469 | .005 | .027 | .061 | .098 |
| 3/8 | 1 1/2 | 2.07 | .563 | .007 | .037 | .106 | .141 |
| 3/8 | 2 | 2.76 | .750 | .009 | .048 | .250 | .250 |
| 3/8 | 3 | 4.11 | 1.125 | .013 | .069 | .844 | .563 |
| 5/16† | 6 | 6.67 | 1.875 | .015 | .096 | 5.625 | 1.875 |
| 1/2 | 3/4 | 1.37 | .375 | .008 | .031 | .018 | .047 |
| 1/2 | 1 1/2 | 2.76 | .750 | .016 | .064 | .141 | .188 |
| 1/2 | 2 | 3.68 | 1.000 | .021 | .084 | .333 | .333 |
| 1/2 | 3 | 5.48 | 1.500 | .031 | .124 | 1.125 | .750 |
| 3/4 | 1 | 2.74 | .750 | .035 | .094 | .063 | .125 |
| 3/4 | 1 1/2 | 4.11 | 1.125 | .053 | .141 | .210 | .281 |
| 3/4 | 2 | 5.53 | 1.500 | .070 | .188 | .500 | .500 |

**ROUND BARS**

16' lengths, except as noted

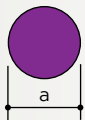

| a | lb/ft | Area | I | S |
|--------|-------|-------|-------|-------|
| 1/2 | .72 | .196 | .003 | .012 |
| 5/8 | 1.13 | .307 | .008 | .024 |
| 3/4 | 1.63 | .442 | .016 | .041 |
| 7/8 | 2.22 | .601 | .029 | .066 |
| 1 | 2.89 | .785 | .049 | .098 |
| 1 1/4 | 4.52 | 1.227 | .120 | .192 |
| 1 1/2 | 6.51 | 1.767 | .249 | .331 |
| 1 5/8 | 7.50 | 2.074 | .342 | .421 |
| 2* | 11.57 | 3.142 | .785 | .785 |
| 3** | 26.10 | 7.069 | 3.974 | 2.649 |
| 3 1/2† | 35.00 | 9.621 | 7.362 | 4.209 |

* 12' lengths, ** 10' lengths, † 8' lengths

● NICKEL-SILVER Alloy C79800 Mill Finish, except as noted

All dimensions in inches and weight in pounds per lineal foot

SQUARE BARS

Sharp Corners
16' lengths, except as noted

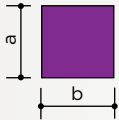

| a | b | lb/ft | Area | I | S |
|---------|-------|-------|-------|------|------|
| 1/2 | 1/2 | .92 | .250 | .005 | .021 |
| 3/4 | 3/4 | 2.08 | .563 | .026 | .070 |
| 1 | 1 | 3.69 | 1.000 | .083 | .167 |
| 1 1/4 | 1 1/4 | 5.76 | 1.563 | .204 | .326 |
| 1 1/2** | 1 1/2 | 8.28 | 2.250 | .422 | .563 |

** 10' lengths

TUBING

Square
Sharp Corners
16' lengths

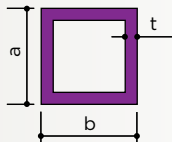

| a | b | t | lb/ft | Area | I | S |
|-------|-------|------|-------|------|------|------|
| 3/4 | 3/4 | .093 | .90 | .244 | .018 | .048 |
| 1 | 1 | .100 | 1.32 | .360 | .049 | .098 |
| 1 1/4 | 1 1/4 | .100 | 1.70 | .460 | .102 | .163 |
| 1 1/2 | 1 1/2 | .100 | 2.07 | .560 | .184 | .245 |
| 2 | 2 | .100 | 2.83 | .760 | .458 | .459 |

Rectangular

Sharp Corners
16' lengths

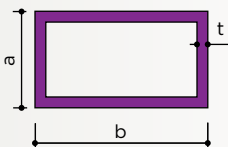

| a | b | t | lb/ft | Area | I _x | S _x | C _x | I _y | S _y | C _y |
|---------|-------|------|-------|-------|----------------|----------------|----------------|----------------|----------------|----------------|
| 3/4 | 1 1/2 | .100 | 1.50 | .410 | .035 | .093 | - | .110 | .147 | - |
| 1 | 2 | .100 | 2.07 | .560 | .090 | .180 | - | .278 | .278 | - |
| 1 1/4 ● | 2 3/4 | .125 | 3.40 | .930 | .237 | .379 | .625 | .851 | .619 | 1.375 |
| 1 1/2 | 3 | .125 | 3.88 | 1.022 | .384 | .512 | - | 1.167 | .778 | - |
| 1 3/4 | 3 | .125 | 4.15 | 1.125 | .566 | .647 | - | 1.338 | .892 | - |
| 1 3/4 | 4 | .125 | 5.28 | 1.375 | .732 | .836 | - | 2.742 | 1.371 | - |

● Item No. 1334 Rounded Corners

Round

16' lengths, except as noted

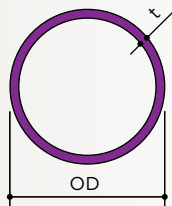

| OD | t | lb/ft | Area | I | S |
|----------|------|-------|-------|-------|------|
| 1 1/2* ● | .100 | 1.75 | .440 | .108 | .144 |
| 1.900* ● | .109 | 2.25 | .721 | .641 | .247 |
| 2 1/2 | .125 | 3.44 | .933 | .659 | .527 |
| 3 | .125 | 4.50 | 1.129 | 1.169 | .779 |

● Item No. 5289* 20' lengths

Oval

20' lengths

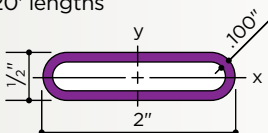

| | lb/ft | Area | I _x | S _x | I _y | S _y |
|----------------------|-------|------|----------------|----------------|----------------|----------------|
| ● 5288 Nickel-Silver | 1.56 | .426 | .011 | .044 | .152 | .152 |

● STAINLESS Type 304 (18-8) Mill Finish, smooth surface, suitable for polishing

All dimensions in inches and weight in pounds per lineal foot

ROLLED ANGLES

20' lengths

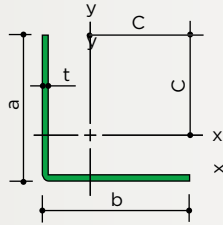

| a | b | t | lb/ft | Area | I | S | Cx | Cy |
|-------|-------|------|-------|------|------|------|-------|----|
| 1/2 | 1/2 | .062 | .192 | .058 | .001 | .004 | .352 | |
| 5/8 | 5/8 | .062 | .247 | .074 | .003 | .006 | .446 | |
| 3/4 | 3/4 | .062 | .296 | .089 | .005 | .009 | .539 | |
| 3/4 | 3/4 | .125 | .596 | .172 | .009 | .017 | .517 | |
| 1 | 1 | .062 | .410 | .120 | .012 | .016 | .727 | |
| 1 | 1 | .125 | .808 | .234 | .022 | .031 | .704 | |
| 1 1/4 | 1 1/4 | .062 | .507 | .151 | .023 | .025 | .914 | |
| 1 1/4 | 1 1/4 | .125 | 1.020 | .297 | .044 | .049 | .891 | |
| 1 1/2 | 1 1/2 | .062 | .605 | .182 | .041 | .037 | 1.102 | |
| 1 1/2 | 1 1/2 | .125 | 1.240 | .359 | .078 | .072 | 1.079 | |

ROLLED CHANNELS

20' lengths, except as noted

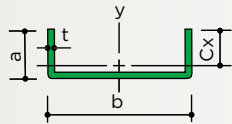

| b | a | t | lb/ft | Area | Ix | Sx | Cx | Iy | Sy |
|-------|------|------|-------|------|------|------|------|------|------|
| 1/2 | 1/2 | .062 | .284 | .085 | .002 | .007 | .310 | .003 | .013 |
| 5/8* | 5/16 | .078 | .293 | .085 | .001 | .003 | .206 | .004 | .014 |
| 3/4 | 3/8 | .062 | .279 | .085 | .001 | .004 | .259 | .001 | .003 |
| 3/4 | 3/4 | .062 | .451 | .132 | .015 | .024 | .621 | .012 | .033 |
| 1 | 1/2 | .062 | .385 | .116 | .003 | .007 | .350 | .017 | .034 |
| 1 | 1 | .062 | .591 | .178 | .019 | .029 | .643 | .031 | .062 |
| 1 1/4 | 1/2 | .062 | .452 | .132 | .003 | .008 | .366 | .029 | .047 |
| 1 1/2 | 1/2 | .062 | .492 | .147 | .003 | .008 | .377 | .046 | .061 |

* 22' lengths

TRUE BARS

Sharp Corners
12' to 14' lengths

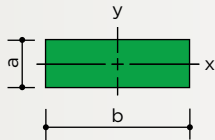

| a | b | lb/ft | Area | Ix | Sx | Iy | Sy |
|------|-------|-------|-------|------|------|-------|-------|
| 3/16 | 3/4 | .478 | .141 | .000 | .004 | .007 | .018 |
| 3/16 | 1 | .638 | .188 | .001 | .006 | .016 | .032 |
| 3/16 | 1 1/4 | .797 | .235 | .001 | .007 | .031 | .050 |
| 3/16 | 1 1/2 | .957 | .282 | .001 | .009 | .053 | .071 |
| 3/16 | 2 | 1.280 | .376 | .001 | .012 | .125 | .125 |
| 3/16 | 3 | 1.990 | .564 | .002 | .018 | .422 | .281 |
| 1/4 | 3/4 | .636 | .188 | .001 | .008 | .009 | .023 |
| 1/4 | 1 | .850 | .250 | .001 | .008 | .021 | .042 |
| 1/4 | 1 1/4 | 1.060 | .313 | .002 | .016 | .041 | .066 |
| 1/4 | 1 1/2 | 1.280 | .375 | .002 | .016 | .070 | .093 |
| 1/4 | 2 | 1.700 | .500 | .003 | .024 | .167 | .167 |
| 1/4 | 2 1/2 | 2.120 | .625 | .003 | .024 | .326 | .261 |
| 1/4 | 3 | 2.550 | .750 | .004 | .032 | .563 | .375 |
| 1/4 | 4 | 3.400 | 1.000 | .005 | .040 | 1.333 | .667 |
| 3/8 | 1 | 1.280 | .375 | .004 | .021 | .031 | .062 |
| 3/8 | 1 1/4 | 1.590 | .469 | .005 | .027 | .061 | .098 |
| 3/8 | 1 1/2 | 1.920 | .563 | .007 | .037 | .106 | .141 |
| 3/8 | 2 | 2.550 | .750 | .009 | .048 | .250 | .250 |
| 3/8 | 2 1/2 | 3.190 | .938 | .011 | .059 | .488 | .390 |
| 3/8 | 3 | 3.830 | 1.125 | .013 | .069 | .844 | .563 |
| 3/8 | 4 | 5.100 | 1.500 | .018 | .096 | 2.000 | 1.000 |
| 1/2 | 3/4 | 1.280 | .375 | .008 | .031 | .018 | .047 |
| 1/2 | 1 | 1.700 | .500 | .010 | .040 | .042 | .084 |
| 1/2 | 1 1/2 | 2.550 | .750 | .016 | .064 | .141 | .188 |
| 1/2 | 2 | 3.400 | 1.000 | .021 | .084 | .333 | .333 |
| 1/2 | 2 1/2 | 4.250 | 1.250 | .026 | .104 | .651 | .520 |
| 1/2 | 3 | 5.100 | 1.500 | .031 | .124 | 1.125 | .750 |
| 1/2 | 4 | 6.800 | 2.000 | .042 | .168 | 2.667 | 1.333 |
| 3/4 | 1 | 2.550 | .750 | .035 | .094 | .063 | .125 |
| 3/4 | 1 1/2 | 3.830 | 1.125 | .053 | .141 | .210 | .281 |
| 3/4 | 2 | 5.100 | 1.500 | .070 | .188 | .500 | .500 |
| 3/4 | 3 | 7.650 | 2.250 | .106 | .281 | 1.688 | 1.125 |
| 1 | 1 1/2 | 5.100 | 1.500 | .125 | .250 | .281 | .375 |



● STAINLESS Type 304 (18-8) Mill Finish, smooth surface, suitable for polishing

All dimensions in inches and weight in pounds per lineal foot

ROUND BARS

12'-14' lengths

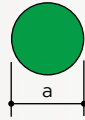

| a | lb/ft | Area | I | S |
|--------|-------|-------|------|------|
| 3/8 | .378 | .110 | .001 | .005 |
| 1/2 | .671 | .196 | .003 | .012 |
| 9/16* | .850 | .249 | .005 | .018 |
| 5/8 | 1.050 | .307 | .008 | .024 |
| 3/4 | 1.510 | .442 | .016 | .041 |
| 7/8* | 2.060 | .601 | .029 | .066 |
| 1* | 2.680 | .785 | .049 | .098 |
| 1 1/4* | 4.200 | 1.227 | .120 | .192 |

*Type 303

SQUARE BARS

Sharp Corners
12'-14' lengths

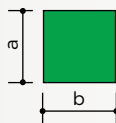

| a | b | lb/ft | Area | I | S |
|-------|-------|-------|-------|------|------|
| 1/2 | 1/2 | .855 | .250 | .005 | .021 |
| 5/8 | 5/8 | 1.330 | .391 | .013 | .041 |
| 3/4 | 3/4 | 1.920 | .563 | .026 | .070 |
| 1 | 1 | 3.420 | 1.000 | .083 | .167 |
| 1 1/4 | 1 1/4 | 5.310 | 1.563 | .204 | .326 |

HANDRAIL PIPE

Cold-rolled Ornamental Grade
20' lengths
No. 4 Finish, 180 grit,
paper-wrapped

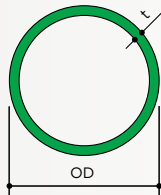

| Nominal Pipe Size | Sched. | OD | t | lb/ft | Area | I | S | r |
|-------------------|--------|-------|------|-------|------|------|------|------|
| 3/4 | 40 | 1.050 | .113 | 1.200 | .333 | .037 | .071 | .334 |
| 1 | 40 | 1.315 | .120 | 1.460 | .494 | .087 | .133 | .421 |
| 1 1/4 | 5 | 1.660 | .062 | 1.110 | .326 | .104 | .125 | .564 |
| 1 1/4 | 40 | 1.660 | .148 | 2.150 | .669 | .195 | .235 | .540 |
| 1 1/2 | 5 | 1.900 | .062 | 1.274 | .375 | .158 | .166 | .649 |
| 1 1/2 | 40 | 1.900 | .148 | 2.550 | .800 | .310 | .326 | .623 |

TUBING

Square

Ornamental Grade
20' lengths

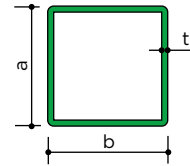

| a | b | t | lb/ft | Area | I | S |
|-------|-------|------|-------|------|------|------|
| 3/4 | 3/4 | .049 | .472 | .137 | .011 | .030 |
| 1 | 1 | .062 | .835 | .234 | .034 | .069 |
| 1 1/4 | 1 1/4 | .062 | 1.058 | .297 | .070 | .112 |
| 1 1/2 | 1 1/2 | .062 | 1.281 | .359 | .124 | .166 |
| 1 3/4 | 1 3/4 | .062 | 1.505 | .422 | .200 | .230 |
| 2 | 2 | .062 | 1.728 | .484 | .303 | .304 |

Rectangular

Ornamental Grade
20' lengths, except as noted

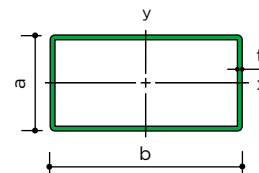

| a | b | t | lb/ft | Area | Ix | Sx | rx | Iy | Sy | ry |
|---------|-------|------|-------|------|------|------|------|-------|------|-------|
| 3/4 | 1 1/2 | .062 | .946 | .266 | .025 | .066 | .305 | .076 | .101 | .533 |
| 1 | 1 1/2 | .062 | 1.048 | .297 | .048 | .096 | .403 | .092 | .122 | .556 |
| 1 | 2 | .062 | 1.281 | .359 | .062 | .124 | .415 | .186 | .186 | .719 |
| 1 | 3 | .062 | 1.728 | .484 | .089 | .179 | .430 | .517 | .345 | 1.033 |
| 1 1/4 | 2 1/2 | .062 | 1.616 | .453 | .125 | .200 | .525 | .372 | .297 | .906 |
| 1 3/4*3 | | .062 | 2.062 | .578 | .312 | .356 | .734 | .720 | .480 | 1.116 |
| 1 3/4*4 | | .062 | 2.683 | .703 | .401 | .458 | .755 | 1.454 | .727 | 1.438 |

*21'-1" lengths

Round

Ornamental Grade
20' lengths

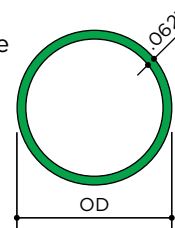

| OD | ID | lb/ft | Area | I | S |
|-------|-------|-------|------|-------|------|
| 2 1/2 | 2.375 | 1.691 | .497 | .369 | .295 |
| 3 | 2.875 | 1.930 | .577 | .622 | .415 |
| 4 | 3.875 | 2.550 | .804 | 1.556 | .778 |

Oval

Ornamental Grade
20' lengths

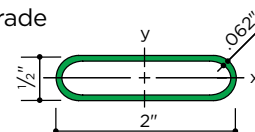

| | lb/ft | Area | Ix | Sx | Iy | Sy |
|--------|-------|------|------|------|------|------|
| ● 4488 | .944 | .284 | .011 | .046 | .107 | .107 |

Availability of complete structural information enables architects and designers to make proper use of Blum's component systems to provide safe, durable handrail installations. The designer can engineer installations to conform to specific building code loading criteria or can establish design requirements for a given installation on the basis of anticipated traffic exposure.

The five major considerations for the structural designs of handrails are:

1. Structural loading criteria as established by governing building codes or special design requirements.
2. Properties of railing materials and allowable stresses for design.
3. Elements of sections for railing components.
4. Load, stress, and deflection relationships expressed as formulas for engineering design.
5. Proper attachment and sound supporting structure.

CODE REQUIREMENTS AND REGULATIONS

Structural requirements for railings are usually expressed in one of two ways, depending on governing codes and regulations. Some of these specify an applied loading distributed uniformly along the rail while others specify loading concentrated on the top rail. The designer should consult governing codes, local ordinances, project specifications and regulatory authorities to determine requirements for compliance.

The Americans with Disabilities Act (ADA): Refer to page 3 for information regarding handrail dimensions mentioned in the ADA Accessibility Guidelines and ANSI 117.1-17.

ALLOWABLE STRESSES

To provide adequate safety factors, the engineering profession assigns to each material an allowable design stress, which is usually expressed as a specific fraction of minimum yield, or sometimes as a smaller fraction of minimum ultimate strength. Allowable stresses vary with the composition and temper of the material and also, to some degree, with the kind of shape and the direction of stress.

Yield strength is the point of stress (in pounds per square inch) at which material fails to return to its original position after the stress has been removed and takes a permanent set. Minimum yield is defined as the test value exceeded by 99% of a large number of specimens. For non-ferrous metals, the yield point is arbitrarily defined as the point of stress at which permanent set is a specific fraction of 1% of the length of the test piece (0.2% offset as shown below or 0.5% elongation). Ultimate strength is considerably higher (see graph).

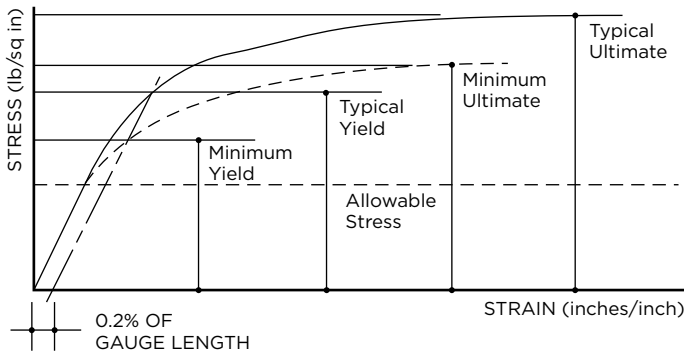

ELEMENTS OF SECTIONS

Properties of sections of JB® handrail mouldings, posts, and support sections are listed on page 123. For properties of bars, shapes and tubes, see pages 106-121.

MECHANICAL PROPERTIES OF MATERIALS

Below is a table of metals used in the architectural components described in this catalog, together with their yields, allowable stresses, and moduli of elasticity. These mechanical properties have been established by producers of the various materials.

| Material | Allowable Bending Stress for Design (psi) | Expected Minimum Yield (psi) | Modulus of Elasticity (psi x 10 ⁶) |
|-----------------------------------------------------|-------------------------------------------|------------------------------|------------------------------------------------|
| Aluminum 6061-T6, shapes | 19,500 | 35,000 | 10.0 |
| major axis shapes | 27,700 | 35,000 | 10.0 |
| minor axis | | | |
| Aluminum 6063-T6, shapes | 15,200 | 25,000 | 10.0 |
| major axis shapes | 19,700 | 25,000 | 10.0 |
| minor axis | | | |
| Aluminum 6063-T52, bars and shapes | 12,600 | 16,000 | 10.0 |
| Aluminum 6063-T52, tubing | 11,300 | 16,000 | 10.0 |
| Aluminum 6063-T832, drawn pipe | 24,800 | 35,000 | 10.0 |
| Bronze C38500, extruded | 9,700 | 16,000 | 14.0 |
| Bronze C38500, handrail moulding and tubing | 14,500 | 24,000 | 14.0 |
| Bronze C38500, rectangular tubing, bars, and shapes | 21,200 | 35,000 | 14.0 |
| Red Brass C23000, drawn pipe, ASTM B43 | 11,000 | 18,000 | 17.0 |
| Nickel-Silver C79800, extruded | 24,000 | 40,000 | 18.0 |
| Stainless Steel type 304, extruded, ASTM A276 | 15,000 | 25,000 | 28.0 |
| Stainless Steel type 304, hot-rolled, ASTM A276 | 18,000 | 30,000 | 28.0 |
| Stainless Steel type 304, cold-formed | 15,100 | 28,000 | 28.0 |
| Stainless Steel type 304 round tubing (as welded) | 30,000 | 55,000 | 28.0 |
| Carbon Steel C1010, roll-formed, ASTM A29 | 16,800 | 28,000 | 29.0 |

LOADING DIAGRAM

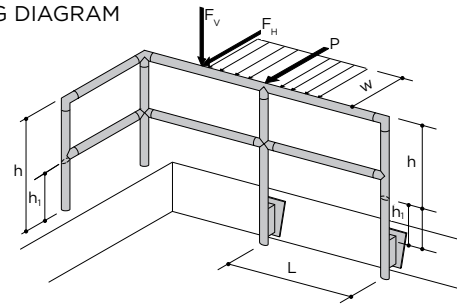

EXPLANATION OF SYMBOLS

- w = Uniform horizontal loading, perpendicular to the rail (lb/ft).
 - L = Span between centerlines of posts or brackets (in.).
 - P = Horizontal force, perpendicular to rail applied at top of post (lb).
 - F_H = Horizontal force, perpendicular to rail at any point along the railing (lb).
 - F_V = Vertical force, perpendicular to rail at any point between posts (lb).
 - h = Height of post. Distance from point of load application above top of attachment (in.).
 - h_i = Distance from top of post attachment to top of reinforcing insert (in.).
 - M = Bending moment (in.-lb).
 - f = Unit stress (psi)
 - f_s = Allowable fibre stress for design (psi).
 - S_x & S_y = Section modulus about the x- or y-axis respectively (in.³).
 - I_x & I_y = Moment of inertia about the x- or y-axis respectively (in.⁴).
 - k = Stiffness of member.
 - K = Bending moment constant.
 - c = Distance from the neutral axis to the extreme fibre of any section (in.).
 - E = Modulus of elasticity (psi x 10⁶).
 - Δ = Deflection (in.).
 - R = Stiffness ratio.
 - P_r = Load proportion factor.
 - F_r = Reaction factor (psi).
- Values for w (uniform load in lb/ft) are converted to lb/in. by dividing by 12

ELEMENTS OF SECTIONS

- ALUMINUM
- BRONZE
- NICKEL-SILVER
- STAINLESS
- STEEL

HANDRAILS

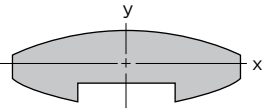

| Shape | Area | Minor Axis | | | Major Axis | | |
|-----------------|-------|------------|----------|----------|------------|----------|----------|
| | | lx (in4) | Sx (in3) | cx (in.) | ly (in4) | Sy (in3) | cy (in.) |
| ● 6402 | 1.250 | 0.083 | 0.098 | 0.845 | 0.412 | 0.347 | 1.188 |
| ● 6407 | 1.680 | 0.088 | 0.104 | 0.844 | 1.311 | 0.807 | 1.625 |
| ● 6436† | 0.741 | 0.159 | 0.268 | 0.594 | 0.422 | 0.386 | 1.094 |
| ● 6437† | 0.879 | 0.210 | 0.336 | 0.625 | 0.799 | 0.532 | 1.500 |
| ● 6530 | 0.810 | 0.032 | 0.082 | 0.395 | 0.315 | 0.315 | 1.000 |
| ● 6531 | 0.573 | 0.023 | 0.056 | 0.411 | 0.132 | 0.175 | 0.750 |
| ● 6532 | 1.090 | 0.039 | 0.084 | 0.465 | 0.616 | 0.493 | 1.250 |
| ● 6540 | 0.628 | 0.312 | 0.284 | 1.099 | 0.034 | 0.068 | 0.500 |
| ● 6901 | 1.387 | 0.042 | 0.106 | 0.396 | 0.709 | 0.540 | 1.313 |
| ● 6902 | 1.227 | 0.034 | 0.084 | 0.409 | 0.520 | 0.438 | 1.188 |
| ● 6903 | 0.361 | 0.013 | 0.029 | 0.448 | 0.109 | 0.125 | 0.875 |
| ● 6904 | 0.726 | 0.072 | 0.118 | 0.612 | 0.519 | 0.377 | 1.375 |
| ● 6905 | 1.414 | 0.026 | 0.089 | 0.297 | 1.167 | 0.718 | 1.625 |
| ● 6906 | 2.051 | 0.058 | 0.161 | 0.358 | 2.195 | 1.171 | 1.845 |
| ● 6907 | 1.441 | 0.031 | 0.077 | 0.402 | 1.263 | 0.777 | 1.625 |
| ● 6929 | 0.557 | 0.018 | 0.042 | 0.425 | 0.260 | 0.231 | 1.125 |
| ● 6930 | 0.779 | 0.023 | 0.052 | 0.449 | 0.300 | 0.267 | 1.125 |
| ● 6931 | 0.527 | 0.011 | 0.030 | 0.358 | 0.108 | 0.133 | 0.813 |
| ● 6932 | 0.684 | 0.059 | 0.100 | 0.586 | 0.616 | 0.429 | 1.438 |
| ● 6933 | 0.670 | 0.013 | 0.035 | 0.369 | 0.175 | 0.200 | 0.875 |
| ● 6934 | 0.669 | 0.017 | 0.040 | 0.427 | 0.208 | 0.214 | 0.969 |
| ● 6935 | 0.843 | 0.024 | 0.053 | 0.451 | 0.343 | 0.323 | 1.065 |
| ● 6939 | 1.845 | 0.085 | 0.225 | 0.375 | 0.932 | 0.746 | 1.250 |
| ● 6984 | 1.079 | 0.021 | 0.056 | 0.367 | 0.676 | 0.492 | 1.375 |
| ● 6985 | 0.805 | 0.017 | 0.040 | 0.413 | 0.254 | 0.254 | 1.000 |
| ● 6986 | 2.237 | 0.104 | 0.277 | 0.375 | 1.658 | 1.106 | 1.500 |
| ● 6987 | 0.746 | 0.056 | 0.084 | 0.662 | 0.648 | 0.471 | 1.375 |
| ● 6988 | 0.946 | 0.019 | 0.075 | 0.250 | 0.285 | 0.285 | 1.000 |
| ● 4529 | 0.684 | 0.059 | 0.100 | 0.586 | 0.616 | 0.429 | 1.438 |
| ● 4530 ● 5530 | 0.779 | 0.023 | 0.052 | 0.449 | 0.300 | 0.267 | 1.125 |
| ● 4531 | 0.527 | 0.011 | 0.030 | 0.358 | 0.108 | 0.133 | 0.813 |
| ● 4533 | 0.937 | 0.457 | 0.372 | 1.229 | 0.785 | 0.571 | 0.916 |
| ● 4534 ● 5534 | 0.669 | 0.017 | 0.040 | 0.427 | 0.208 | 0.214 | 0.969 |
| ● 4535 ● 5235 | 0.799 | 0.024 | 0.052 | 0.454 | 0.344 | 0.323 | 1.063 |
| ● 4538 ● 5538 | 0.806 | 0.194 | 0.202 | 0.958 | 0.661 | 0.481 | 1.375 |
| ● 4539 | 0.670 | 0.013 | 0.035 | 0.369 | 0.175 | 0.200 | 0.875 |
| ● 4572 ● 5572 | 0.701 | 0.008 | 0.032 | 0.239 | 0.299 | 0.266 | 1.125 |
| ● 4573 | 1.054 | 0.016 | 0.059 | 0.268 | 0.654 | 0.476 | 1.375 |
| ● 4574 ● 5274 | 0.919 | 0.020 | 0.053 | 0.376 | 0.654 | 0.476 | 1.375 |
| ● 4575 | 0.645 | 0.014 | 0.033 | 0.437 | 0.232 | 0.232 | 1.000 |
| ● 6488† ● 5288† | 0.426 | 0.011 | 0.044 | 0.250 | 0.152 | 0.152 | 1.000 |
| ● 6489† ● 5289† | 0.440 | 0.108 | 0.144 | 1.250 | 0.108 | 0.144 | 1.250 |
| ● 4488† | 0.284 | 0.011 | 0.046 | 0.250 | 0.107 | 0.107 | 1.000 |
| ● 6501 | 1.054 | 0.017 | 0.067 | 0.256 | 0.629 | 0.457 | 1.375 |
| ● 6502 | 0.740 | 0.008 | 0.033 | 0.235 | 0.314 | 0.280 | 1.125 |
| ● 6503 | 0.739 | 0.014 | 0.050 | 0.341 | 0.126 | 0.168 | 0.750 |
| ● 6511† | 0.386 | 0.006 | 0.031 | 0.238 | 0.189 | 0.137 | 1.375 |
| ● 6512† | 0.291 | 0.008 | 0.034 | 0.236 | 0.136 | 0.121 | 1.125 |
| ● 4416 | 0.927 | 0.021 | 0.073 | 0.291 | 0.232 | 0.231 | 1.000 |
| ● 4428 | 0.569 | 0.017 | 0.041 | 0.416 | 0.209 | 0.215 | 0.969 |
| ● 4429 | 0.403 | 0.008 | 0.022 | 0.375 | 0.104 | 0.119 | 0.875 |
| ● 4435 | 0.746 | 0.018 | 0.044 | 0.406 | 0.349 | 0.328 | 1.062 |
| ● 4441 | 0.594 | 0.024 | 0.055 | 0.432 | 0.291 | 0.258 | 1.125 |

†Tubing

CARLSTADT® POSTS

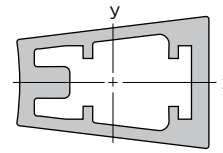

| Shape | Area | Minor Axis | | | Major Axis | | |
|------------------|-------|------------|----------|----------|------------|----------|----------|
| | | lx (in4) | Sx (in3) | cx (in.) | ly (in4) | Sy (in3) | cy (in.) |
| ● 436E† | 0.655 | 0.029 | 0.078 | 0.370 | 0.087 | 0.140 | 0.622 |
| ● 6423 (423) | 1.555 | 0.201 | 0.321 | 0.625 | 0.201 | 0.321 | 0.625 |
| ● 6424 (424) | 3.430 | 0.445 | 0.712 | 0.625 | 2.153 | 1.566 | 1.375 |
| ● 6427 (427) | 1.926 | 0.208 | 0.303 | 0.687 | 0.496 | 0.409 | 0.789 |
| ● 6430 (430)† | 0.726 | 0.096 | 0.192 | 0.500 | 0.241 | 0.297 | 0.813 |
| ● 6434† ● 1334† | 0.930 | 0.237 | 0.379 | 0.625 | 0.851 | 0.619 | 1.375 |
| ● 6435† †† | 0.871 | 0.210 | 0.337 | 0.625 | 0.710 | 0.516 | 1.375 |
| ● 6458 (458)† †† | 1.110 | 0.177 | 0.258 | 0.687 | 0.529 | 0.508 | 1.042 |
| ● 6459 (459)† †† | 1.030 | 0.201 | 0.322 | 0.687 | 0.708 | 0.679 | 1.041 |
| ● 4830 (830)† | 0.726 | 0.096 | 0.192 | 0.500 | 0.241 | 0.297 | 0.813 |
| ● 230† | 0.308 | 0.050 | 0.100 | 0.500 | 0.095 | 0.126 | 0.750 |
| ● 233B (294)* †† | 1.021 | 0.052 | 0.133 | 0.390 | 0.146 | 0.223 | 0.655 |
| ● 283 (295)* †† | 1.412 | 0.072 | 0.184 | 0.390 | 0.385 | 0.426 | 0.905 |
| ● 280† | 0.373 | 0.064 | 0.128 | 0.500 | 0.193 | 0.193 | 1.000 |

* Aluminum, for use with stainless steel posts † Tubing †† T6 temper

GLASS RAILING SECTIONS

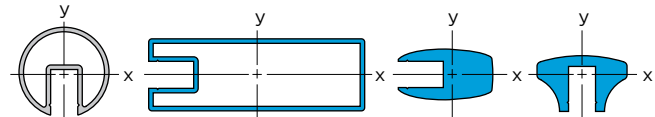

| Railing Number | Area | Minor Axis | | | Major Axis | | |
|----------------|-------|------------|----------|----------|------------|----------|----------|
| | | lx (in4) | Sx (in3) | cx (in.) | ly (in4) | Sy (in3) | cy (in.) |
| ● 1130 | 0.874 | 0.227 | 0.236 | 0.962 | 0.295 | 0.311 | 0.950 |
| ● 1132 ● 1232 | 1.245 | 0.632 | 0.500 | 1.263 | 0.717 | 0.574 | 1.250 |
| ● 1133 | 2.414 | 0.416 | 0.583 | 0.714 | 0.970 | 0.619 | 1.566 |
| ● 1134 | 1.980 | 0.296 | 0.300 | 0.988 | 1.022 | 0.817 | 1.250 |
| ● 1135 | 1.632 | 1.910 | 1.030 | 1.855 | 1.947 | 1.113 | 1.750 |
| ● 1136 | 2.250 | 1.488 | 1.488 | 1.000 | 9.196 | 2.821 | 3.260 |
| ● 1154 | 1.442 | 1.105 | 0.721 | 1.532 | 1.268 | 0.845 | 1.500 |
| ● 1155 | 1.638 | 1.875 | 1.024 | 1.831 | 1.989 | 1.136 | 1.750 |
| ● 1430 | 0.501 | 0.142 | 0.154 | 0.927 | 0.183 | 0.192 | 0.950 |
| ● 1432 ● 1452 | 0.643 | 0.358 | 0.280 | 1.280 | 0.395 | 0.316 | 1.250 |
| ● 1433 ● 1453 | 0.712 | 0.630 | 0.386 | 1.632 | 0.643 | 0.429 | 1.500 |
| ● 1472 ● 1473 | 0.909 | 1.570 | 0.867 | 1.811 | 1.520 | 0.762 | 2.000 |
| ● 1230 | 0.766 | 0.202 | 0.223 | 0.907 | 0.278 | 0.292 | 0.950 |
| ● 1233 ● 1333 | 1.442 | 1.160 | 0.743 | 1.568 | 1.229 | 0.819 | 1.500 |
| ● 1235 | 2.360 | 2.704 | 1.471 | 1.838 | 2.772 | 1.584 | 1.750 |
| ● 1330 | 0.840 | 0.236 | 0.262 | 0.901 | 0.324 | 0.340 | 0.950 |
| ● 1332 | 1.245 | 0.632 | 0.500 | 1.263 | 0.717 | 0.574 | 1.250 |
| ● 1141 | 4.353 | 6.068 | 4.106 | 1.478 | 2.314 | 1.851 | 1.250 |
| ● 1142 | 6.828 | 10.206 | 5.449 | 1.873 | 5.121 | 4.097 | 1.250 |
| ● 1143 | 7.199 | 12.497 | 6.598 | 1.894 | 6.735 | 4.898 | 1.375 |

Unless designated as T6 temper, all aluminum alloy is in the T52 temper. The values of these elements of sections are approximate and—while they have been ascertained with care—they cannot be guaranteed.

See page 128 for properties of Connectorail® pipe and reinforcing bars.

BENDING MOMENTS AND STRESSES

Determination of bending moments and stress in structural railing members follows conventional engineering design procedures. The resisting moment—calculated from the Section Modulus (S , which equals I/c) and Allowable Design Stress (f_s)—must be greater than or equal to the Applied Bending Moment (M).

$$\frac{I}{c} \times f_s = S \times f_s = M$$

This translates into railing formulas as described below.

RAILS: Connections between posts and rails are assumed to be free to pivot, although in practice the rail post connection is normally not a pivot. Distribution of loads through multiple spans decreases maximum bending moment in horizontal members. The effect of different numbers of spans may be taken into account by varying the Bending Moment Constant (K). Calculation of Unit Stress (f) and Length of Span (L) are accomplished by using the following formulas:

1. For uniform vertical or horizontal loads (w):

$$M = \frac{w/12 \times L^2}{K} \quad M = S \times f$$

$$f = \frac{w/12 \times L^2}{S \times K} \quad K = 8 \text{ for one or two spans}$$

$$L = \sqrt{\frac{f \times K \times S}{w/12}} \quad K = 9.5 \text{ for three or more spans of a continuous rail}$$

2. For concentrated loads (F) applied at mid span:

$$M = \frac{F \times L}{K} \quad M = S \times f$$

$$f = \frac{F \times L}{S \times K} \quad K = 4 \text{ for one span}$$

$$L = \frac{S \times K \times f}{F} \quad K = 5 \text{ for two or more spans of a continuous rail}$$

Values of K are defined based on the maximum bending moment developed under various numbers of spans.

POSTS: Posts act as vertical cantilever beams in resisting horizontal thrust applied at the top rail. Bending moment produced by horizontal thrust normally controls design, and post spacing may be calculated using the following equations.

1. For uniform horizontal loading (w):

$$M = P \times h \quad P = w/12 \times L \quad M = S \times f$$

$$f = \frac{w/12 \times L \times h}{S} \quad L = \frac{S \times f}{w/12 \times h}$$

2. For concentrated horizontal loading (F_h):

When concentrated loading is specified, the horizontal load on the top rail is distributed among several posts adjacent to the point of loading. The load distribution is a function of the relative stiffness of post and top rail and of the number of spans in the railing. For a straight run of railing it may be calculated with the aid of the graph on page 129. This calculation will show what proportion (P_f) of the total load any one post may have to sustain. To the extent that it is less than 100%, it will justify the use of lighter and more economical construction. The following equation applies:

$$M = P \times h \quad P = F_h \times P_f$$

$$f = \frac{F_h \times h \times P_f}{S}$$

RAILING FORMULAS

INTERNALLY REINFORCED POSTS

The load-carrying capacity of a post with reinforcing insert is limited by the allowable fibre stress at one of three points.

1. The post at the top of the insert, above which it is not reinforced.
2. The insert at its base, at the highest point of its attachment to the supporting structure.
3. The post at the same point of attachment.

The lowest of these three loading limits controls design for the combined post and reinforcing insert.

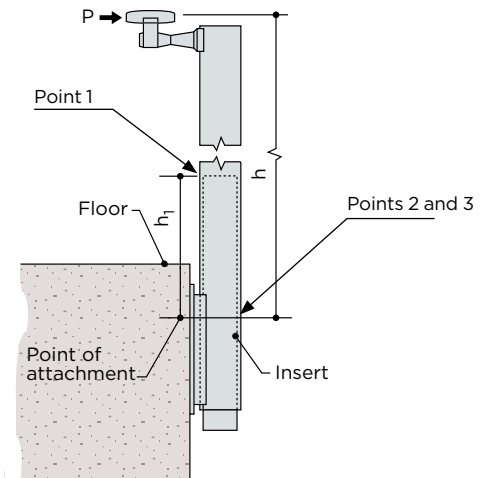

1. Post at top of insert:

Moment in post (top of insert): $M = P \times (h - h_1)$
Fibre stress in post (top of insert):

$$f = \frac{M}{S} = \frac{P \times (h - h_1)}{S}$$

$$\text{Loading limit: } P = \frac{f_s \times S}{h - h_1}$$

At the point of contact between the railing post and the reinforcing insert, the deflection of each is assumed to be the same but the resisting force of each is a function of its Moment of Inertia (I) and Modulus of Elasticity (E). The resultant combined Reaction Factor (F_r) at the top of the insert is determined as follows:

$$F_r = \left(\frac{h}{2 \times h_1} - 0.617 \right) \div \left(\frac{E_p \times I_p}{3 \times E_r \times I_r} + 0.333 \right)$$

E_r and I_r refer to the reinforcing insert
 E_p and I_p refer to the post

The loading limits for points 2 and 3 are then determined as follows:

2. Insert at base:

Moment in insert: $M = P \times (h - h_1)$
Fibre stress in insert

$$f = \frac{M}{S_r} = \frac{P \times F_r \times h_1}{S_r}$$

$$\text{Loading limit: } P = \frac{f_s \times S_r}{F_r \times h_1}$$

RAILING FORMULAS

3. Post at base:

$$\text{Moment in post: } M = P \times [h - (F_r \times h_1)]$$

$$\text{Fibre stress in post: } f = \frac{M}{S_p} = \frac{P \times [h - (F_r \times h_1)]}{S_p}$$

$$\text{Loading limit: } P = \frac{f_s \times S_p}{h - (F_r \times h_1)}$$

COMBINED HANDRAIL SECTIONS

When two sections of the same metal are combined by being fastened together to form a handrail (e.g. a steel moulding mounted on a steel channel), the sections develop the same deflection under load but act independently about their respective neutral axes.

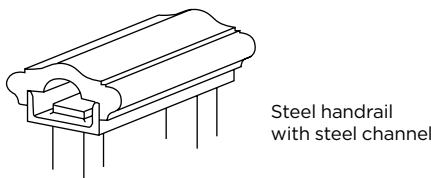

Steel handrail with steel channel

I_a and I_b are the moments of inertia of the two sections. Since the Section Modulus (S) equals I/c , the combined value for S of the two sections would be:

$$S = \frac{I_a + I_b}{c_{\max}} \quad (c_{\max} \text{ is either } c_a \text{ or } c_b, \text{ whichever is greater})$$

In the railing formulas, substitute the above equation for the value of S whenever combined sections of the same material are used.

COMBINED SECTIONS OF DISSIMILAR MATERIALS

To compute the loading of combined sections of dissimilar materials (e.g. a bronze handrail mounted on a steel channel), calculations involve the determination of the relative portion of the load carried by each section. The load distribution is a function of the relative stiffness of the two sections, which is determined by the Moments of Inertia (I) and their Moduli of Elasticity (E). The distribution of the total load between two sections is determined as follows:

$$\text{Load Carried by A} = \frac{\text{Total Load}}{1 + \frac{E_b \times I_b}{E_a \times I_a}}$$

$$\text{Load Carried by B} = \text{Total Load} - \text{Total Load Carried by A}$$

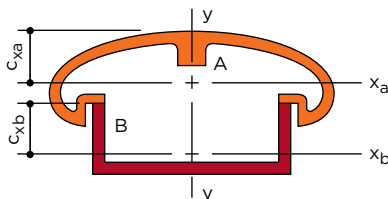

Individual calculation to determine the fibre stress for each material, using the load portion of each section, will then determine which section controls design; namely, the section giving the lesser result (see example 6 on page 127).

DEFLECTION CONSIDERATIONS

Excessive deflection of a railing under load, even though it meets strength requirements, will give the user a feeling of insecurity and may cause tripping or stumbling.

Lateral deflection of posts or vertical deflection of horizontal rails under load are computed as follows—these formulas must be used with caution:

For posts without reinforcing insert:

$$\Delta = \frac{P \times h^3}{3 \times E \times I} \quad \text{or} \quad \frac{w/12 \times L \times h^3}{3 \times E \times I}$$

For posts with reinforcing insert of similar or dissimilar material:

$$\Delta = \frac{P \times (h - h_1)^3}{3 \times E_p \times I_p} + \frac{P \times [h^3 - (h - h_1)^3]}{3 \times [(E_p \times I_p) + (E_r \times I_r)]}$$

Where E_p and I_p apply to post
 E_r and I_r apply to reinforcing insert

For rails (concentrated load, F):

$$\Delta = \frac{F \times L^3}{K \times E \times I}$$

Where K = 48 for simple span
 66 for two or more spans, load on end span
 87 for three or more spans, load on intermediate span

For rails (uniform load, w):

$$\Delta = \frac{5 \times w/12 \times L^4}{384 \times E \times I} \quad \text{for simple spans}$$

$$\Delta = \frac{w/12 \times L^4}{145 \times E \times I} \quad \text{for two or more spans}$$

There are few, if any, regulations or code requirements limiting deflection in a railing but ASTM has put forth the following criteria regarding Maximum Allowable Deflection (Δ_{\max}) in their specification E985.

For horizontal load at midspan:

$$\Delta_{\max} = h/24 + L/96$$

For horizontal load at top of post:

$$\Delta_{\max} = h/12$$

For vertical load at midspan:

$$\Delta_{\max} = L/96$$

In many instances, the anchorage of the railing to the floor, tread, or fascia is subject to a degree of rotation which will add an indeterminate amount to the deflection on the post and rail. Anchorage and supporting structure must be as secure and rigid as possible.

The equations presented have been taken from NAAMM AMP 521-01: Pipe Railing Systems Manual Including Round Tube, 4th Edition" and "NAAMM AMP 510-92: Metal Stairs Manual, 5th Edition.

These sample problems demonstrate how engineering data provided by Julius Blum & Co., Inc. can be used to obtain solutions to practical handrail design problems. Problems are solved by equating the maximum bending moment resulting from applied loading to the resisting moment determined from geometrical section properties and allowable stress. This method can be used to obtain solutions for most installation and loading conditions.

EXAMPLE 1:

DETERMINE MAXIMUM POST SPACING REQUIREMENTS:

Uniform load, $w = 50$ lb/ft
Railing height, $h = 38$ in.

MATERIAL SPECIFIED:

Post: #423 aluminum, 6063-T52
Allowable stress, $f_s = 12,600$ psi (refer to page 122);
Section modulus, $S = .321$ in³ (refer to page 123)

DETERMINE:

Maximum post spacing (simple span), L (in.)
Resisting bending moment, $M_{(resisting)} = f_s \times S$
Applied bending moment, $M_{(applied)} = w/12 \times L \times h$
 $M_{(resisting)}$ must equal $M_{(applied)}$

$$f_s \times S = w/12 \times L \times h$$

$$L = \frac{f_s \times S}{w/12 \times h}$$

$$L = \frac{12,600 \times .321}{50/12 \times 38}$$

$$L = 25.54 \text{ in.}$$

EXAMPLE 2:

DETERMINE REQUIRED SECTION MODULUS OF POST REQUIREMENTS:

Concentrated load, $F = 200$ lbs
Railing height, $h = 42$ in.

MATERIAL SPECIFIED:

Post: Steel tubing
Allowable stress, $f_s = 16,800$ psi (refer to page 122)

DETERMINE:

Section modulus, S , and select a suitable section
Resisting bending moment, $M_{(resisting)} = f_s \times S$
Applied bending moment, $M_{(applied)} = F \times h$
 $M_{(resisting)}$ must equal $M_{(applied)}$

$$f_s \times S = F \times h$$

$$S = \frac{F \times h}{f_s}$$

$$S = \frac{200 \times 42}{16,800}$$

$$S = 0.500 \text{ in}^3$$

EXAMPLE PROBLEMS AND SOLUTIONS

EXAMPLE 3:

DETERMINE MAXIMUM SPAN FOR HANDRAIL MOULDINGS, CONCENTRATED LOAD REQUIREMENTS:

Concentrated load, $F = 200$ lbs

MATERIAL SPECIFIED:

Handrail moulding: #6489, 1 1/2" O.D. bronze tubing
 $f_s = 14,500$ psi; $S_x = .144$ in³

The railing will be installed with more than two consecutive spans, therefore the Bending Moment Constant, $K = 5$ (refer to page 124).

DETERMINE:

Maximum span for handrail moulding, L (in.)
Resisting bending moment, $M_{(resisting)} = f_s \times S$

$$\text{Applied bending moment, } M_{(applied)} = \frac{F \times L}{K}$$

$M_{(resisting)}$ must equal $M_{(applied)}$

$$f_s \times S = \frac{F \times L}{K}$$

$$L = \frac{f_s \times S \times K}{F}$$

$$L = \frac{14,500 \times .144 \times 5.0}{200} = 52.2 \text{ in.}$$

EXAMPLE 4:

DETERMINE MAXIMUM SPAN FOR A COMBINED HANDRAIL SECTION USING SECTIONS OF THE SAME METAL REQUIREMENTS:

Concentrated load, $F = 200$ lbs

MATERIALS SPECIFIED:

Handrail moulding: #6932, aluminum, 6063-T52
 $f_s = 12,600$ psi; $I_{xa} = .059$ in⁴; $c_{xa} = .586$ in.
Support channel: 2" x 1/2" x 1/8" aluminum channel
 $f_s = 12,600$ psi; $I_{xb} = .006$ in⁴; $c_{xb} = .369$ in.
 $c_{max} = .586$ in. (greater of c_{xa} vs. c_{xb})

The railing will be installed with more than two consecutive spans, therefore the Bending Moment Constant, $K = 5$ (refer to page 124).

DETERMINE:

Maximum span for combined handrail section, L (in.)

$$\text{Resisting bending moment, } M_{(resisting)} = f_s \times \left(\frac{I_{xa} + I_{xb}}{c_{max}} \right)$$

$$\text{Applied bending moment, } M_{(applied)} = \frac{F \times L}{K}$$

$M_{(resisting)}$ must equal $M_{(applied)}$

$$f_s \times \left(\frac{I_{xa} + I_{xb}}{c_{max}} \right) = \frac{F \times L}{K}$$

$$L = \frac{f_s \times (I_{xa} + I_{xb}) \times K}{F \times c_{max}}$$

$$L = \frac{12,600 \times (.059 + .006) \times 5.0}{200 \times .586} = 35 \text{ in.}$$

EXAMPLE PROBLEMS AND SOLUTIONS

EXAMPLE 5: CONCENTRATED LOAD

LOAD DISTRIBUTION AMONG POSTS DESCRIPTION:

Railing for an air terminal public area— heavy pedestrian traffic is expected.

REQUIREMENTS:

Loading, $F = 300$ lbs

Railing height = 42" at platforms;
34" at stairs

Post height, h : Posts are fascia mounted; top of post attachment is 2" below walking surface. Therefore post height is railing height plus 2".

Maximum opening to be no more than 4"; 12 or more spans between posts.

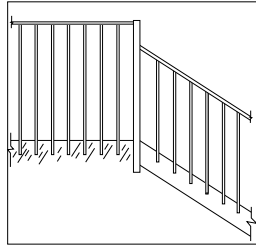

MATERIALS SPECIFIED:

Handrail moulding: #6901, aluminum 6063-T52

$f_s = 12,600$ psi; $E = 10 \times 10^6$; $I_y = .709$ in⁴; $S_y = .540$ in³

Intermediate posts: #430, aluminum 6063-T6

$f_s = 15,200$ psi; $E = 10 \times 10^6$; $I = .241$ in⁴; $S = .297$ in³

End posts: $2\frac{1}{2}$ " x $2\frac{1}{2}$ " x $\frac{3}{16}$ " square aluminum - 6061-T6 - tubing

$f_s = 19,500$ psi; $E = 10 \times 10^6$; $S = 1.247$ in³

DETERMINE:

Structural compliance of proposed construction.

1. Stress at base of end posts (end posts are dissimilar from intermediate posts—they have to resist 100% of horizontal load):

$$f = \frac{P \times h}{S} = \frac{300 \times 44}{1.247} = 10,585 \text{ psi}$$

(19,500 psi allowable)

2. Stress at base of intermediate posts at platform ($L = 4$ in, $h = 44$ in.):

A. Stiffness ratio:

$$R = \frac{E_r \times I_r}{L} \div \frac{E_p \times I_p}{h} = \frac{.709 \times 44}{4 \times .241} = 32.36$$

B. Load proportion factor: (see graph, p. 131) = 0.236

C. Load per post: $300 \times 0.236 = 70.8$ lbs

D. Stress at base of post:

$$f = \frac{P \times h}{S} = \frac{70.8 \times 44}{.297} = 10,489 \text{ psi}$$

(15,200 psi allowable)

3. Stress at base of intermediate post at stairs ($L = 4$ in., $h = 36$ in.):

A. Stiffness ratio:

$$R = \frac{E_r \times I_r}{L} \div \frac{E_p \times I_p}{h} = \frac{.709 \times 36}{4 \times .241} = 26.47$$

B. Load proportion factor: (see graph, p. 131) = 0.248

C. Load per post: $300 \times 0.248 = 74.4$ lbs

D. Stress at base of post:

$$f = \frac{P \times h}{S} = \frac{74.4 \times 36}{.297} = 9,018 \text{ psi}$$

(15,200 psi allowable)

4. Stress on handrail at mid-span:

$$f = \frac{F_h \times L}{S \times K} = \frac{300 \times 4}{.540 \times 5} = 444 \text{ psi}$$

(12,600 psi allowable)

Railing meets structural designer's requirements.

EXAMPLE 6: UNIFORMLY DISTRIBUTED LOAD

COMBINED HANDRAIL SECTION OF DISSIMILAR MATERIALS

DESCRIPTION:

Stair railing of steel balusters, mounted between steel channel top and bottom rails, attached to square steel posts, with a bronze handrail.

REQUIREMENTS:

Loading, $w = 50$ lb/ft, horizontal and vertical.

Railing height, $h = 34$ " at stair, 42" at landings.

Post spacing, $L = 40$ "; 3 or more spans in each run.

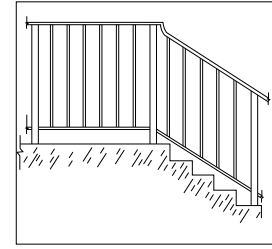

MATERIALS SPECIFIED:

Handrail moulding: #4530, bronze C38500

$f_s = 9,700$ psi; $I_x = .023$ in⁴; $c_x = 0.449$ in.; $E = 14 \times 10^6$ psi

Posts: $1\frac{1}{2}$ " x $1\frac{1}{2}$ " x $.140$ " structural steel tubing

$f_s = 27,700$ psi; $S = .316$ in³

Sub-rails: $1\frac{1}{2}$ " x $\frac{1}{2}$ " x $\frac{1}{8}$ " steel (C1010) channel — top and

bottom: $f_s = 16,800$ psi; $I_x = .005$ in⁴; $c_x = 0.354$ in.;

$E = 29 \times 10^6$ psi

DETERMINE:

Structural compliance of proposed construction

1. Stress at base of post:

$$\frac{M}{S} = \frac{w/12 \times L \times h}{S} \quad \text{At stairs:} \quad \frac{50 \times 40 \times 34}{12 \times .316} = 17,932 \text{ psi}$$

$$\text{At landings:} \quad \frac{50 \times 40 \times 42}{12 \times .316} = 22,152 \text{ psi}$$

(27,700 psi allowable)

2. Stress on rail:

Since I_y of both bronze_(b) and steel_(s) sections is greater than I_x , vertical load controls design.

A. Total load:

$$w/12 \times L = \frac{50 \times 40}{12} = 167 \text{ lbs}$$

B. Load per foot on bronze, w_b :

$$w_b = w \div \left(1 + \frac{E_s \times 2 \times I_{xs}}{E_b \times I_{xb}} \right)$$

$$w_b = 50 \div \left(1 + \frac{29 \times 10^6 \times 2 \times .005}{14 \times 10^6 \times .023} \right) = 26.31 \text{ lb/ft}$$

C. Load per foot on steel, w_s :

$$w_s = w - w_b$$

$$w_s = 50 - 26.31 = 23.69 \text{ lb/ft}$$

D. Stress on bronze, f_{sb} :

$$f_{sb} = \frac{w_b / 12 \times L^2 \times c_{max}}{I_{xb} \times K} = \frac{26.31 / 12 \times 40^2 \times 0.449}{.023 \times 9.5}$$

$$= 7,209 \text{ psi (9,700 psi allowable)}$$

E. Stress on steel, f_{ss} :

$$f_{ss} = \frac{w_s / 12 \times L^2 \times c_{max}}{I_{xs} \times K} = \frac{23.69 / 12 \times 40^2 \times 0.354}{2 \times .005 \times 9.5}$$

$$= 11,770 \text{ psi (16,800 psi allowable)}$$

Design meets code structural requirements.

Resistance to vertical loading of upper and lower steel channels is additive. Therefore the value of I_{xs} is doubled. The additional resistance to vertical load by the truss action of the balusters has not been considered, making the result of the calculation more conservative.

MECHANICAL PROPERTIES

| Material | Allowable Stress (psi) | Minimum Yield (psi) | Modulus of Elasticity (psi x 10 ⁶) |
|-----------------------|------------------------|---------------------|------------------------------------------------|
| ● Aluminum* | | | |
| 6061-T6 | 19,500 | 35,000 | 10.0 |
| 6063-T52 pipe | 11,300 | 16,000 | 10.0 |
| 6063-T832 pipe | 24,800 | 35,000 | 10.0 |
| ● Red Brass C23000 | 11,000 | 18,000 | 17.0 |
| ● Stainless• Type 304 | 30,000 | 55,000 | 28.0 |

*Aluminum Association Specifications for Aluminum Structures.

• American Iron & Steel Institute Stainless Steel Cold-Formed Structural Design Manual.

SECTION PROPERTIES

Connectorail® Pipe (Aluminum, Bronze, Stainless)

| Nominal Size | Sched. | OD | Wall | Area | I | S |
|--------------|--------|--------|-------|------|------|------|
| 1 1/4" | 10 | 1.660" | .109" | .531 | .161 | .193 |
| 1 1/4" | 40 | 1.660" | .140" | .669 | .195 | .235 |
| 1 1/4" | 40 | 1.660" | .146" | .695 | .201 | .242 |
| 1 1/2" | 5 | 1.900" | .062" | .375 | .158 | .166 |
| 1 1/2" | 10 | 1.900" | .109" | .614 | .247 | .260 |
| 1 1/2" | 40 | 1.900" | .145" | .800 | .310 | .326 |
| 1 1/2" | 40 | 1.900" | .150" | .825 | .318 | .335 |

Connectorail® Reinforcing Bars (6061-T6)

| No. | Sched. | Nominal Size | OD | Area | I | S |
|--------------|--------|--------------|--------|-------|------|------|
| ● 7192 | 10 | 1 1/4" | 1.427" | 1.599 | .204 | .285 |
| ● 7292/7295 | 10 | 1 1/2" | 1.667" | 2.183 | .379 | .455 |
| ● 7492 | 40 | 1 1/4" | 1.328" | 1.452 | .168 | .247 |
| ● 7592/ 7595 | 40 | 1 1/2" | 1.585" | 1.973 | .310 | .391 |
| ● 9392** | 5 | 1 1/2" | 1.750" | .615 | .205 | .239 |

** Tubing with .120" wall, type 304 Stainless Steel

CONNECTORAIL® TEST RESULTS

1 1/2" Aluminum and Stainless Steel Pipe—Single Span

| Span (L) or Height (h) | RAIL | | | | | | | | POST | | | | | | | |
|-----------------------------------|------------|---------------|------------|---------------|------------|---------------|------------|---------------|------------|---------------|------------------|---------------|------------------|---------------|------------------|---------------|
| | 57 | | 75 | | 96 | | 96 | | 96 | | 42" w/24" re-bar | | 42" w/24" re-bar | | 42" w/24" re-bar | |
| Schedule | 10 | | 40 | | 10 | | 40 | | 5 | | 10 | | 40 | | 5 | |
| Alloy and Temper | 6063-T52 | | 6063-T52 | | 6063-T832 | | 6063-T832 | | Type 304 | | 6063-T832 | | 6063-T832 | | Type 304 | |
| Load (P) | Deflection | Permanent Set | Deflection | Permanent Set | Deflection | Permanent Set | Deflection | Permanent Set | Deflection | Permanent Set | Deflection | Permanent Set | Deflection | Permanent Set | Deflection | Permanent Set |
| 200 lbs | .344" | .000" | .547" | .000" | 1.466" | .000" | 1.021" | .000" | .867" | .025" | 1.389" | .000" | 1.724" | .000" | 1.006" | .036" |
| 250 lbs | .388" | .000" | .669" | .000" | 1.818" | .000" | 1.317" | .000" | 1.120" | .040" | 1.659" | .000" | 2.122" | .000" | 1.160" | .056" |
| 300 lbs | .496" | .000" | .845" | .000" | 2.214" | .000" | 1.594" | .000" | 1.395" | .128" | 1.926" | .000" | 2.537" | .000" | 1.369" | .080" |
| 350 lbs | .565" | .000" | .998" | .000" | 2.483" | .000" | 1.882" | .000" | 1.728" | .205" | 2.206" | .000" | 2.849" | .000" | 1.633" | .112" |
| 400 lbs | .739" | .047" | 1.189" | .000" | 2.984" | .000" | 2.178" | .000" | 1.992" | .322" | 2.601" | .000" | 3.211" | .000" | | |
| 450 lbs | 1.368" | .488" | 1.654" | .151" | 3.464" | .047" | 2.488" | .000" | 2.563" | .652" | 2.811" | .000" | 3.603" | .000" | 2.131" | .238" |
| 500 lbs | | | 1.990" | .656" | 4.510" | .406" | 2.775" | .000" | 2.972" | .994" | 3.122" | .000" | 4.278" | .109" | 2.270" | .452" |
| 550 lbs | | | | | | | 3.080" | .000" | 4.176" | 1.726" | 3.484" | .000" | 4.868" | .266" | | |
| 600 lbs | | | | | | | 3.424" | .000" | 5.591" | 2.886" | 3.860" | .146" | | | 2.765" | |
| 650 lbs | | | | | | | 3.754" | .031" | | | 4.267" | .391" | | | | |
| 700 lbs | | | | | | | 4.213" | .192" | | | | | | | 3.880" | |
| 0.2% Specified Permanent set load | 430 lbs | | 440 lbs | | 470 lbs | | 700 lbs | | 350 lbs | | 590 lbs | | 490 lbs | | 340 lbs | |

NOTE ON WELDED PIPE RAILINGS

An important consideration for welded pipe railings is the effect of welding heat on the structural properties of aluminum handrail pipe. For example, extruded pipe of aluminum alloy 6063-T52 has an allowable design stress of 11,300 psi. After welding, the allowable stress must be reduced to 8,000 psi within 1" of the weld. Since maximum bending moment generally occurs at points of support or attachment, the reduced stress will often control design. This consideration does not apply to non-welded Connectorail®.

LOADING TABLES

The values tabulated in the following page apply to installations fabricated and erected in accordance with Connectorail® specifications and using Connectorail® components exclusively. Chart values have been determined by assuming that reinforcing inserts are included with fascia mounted railings and with railings set into the floor, except where no insert is indicated.

For these tables, various post heights have been selected arbitrarily. Values of maximum post spacing for other post heights can be interpolated easily.

When Connectorail® posts are surface-mounted on floors, treads or stringers, using a floor flange, the entire bending moment of the post is transferred to the reinforcing insert and the allowable post loading has to be computed accordingly. The allowable load will be determined by the resisting moment of the reinforcing insert alone or the unreinforced post above the insert (h - h₁), whichever is less.

● ALUMINUM ● BRONZE ● STAINLESS

CONNECTORAIL® LOAD TABLES

Maximum Allowable Spans—Post Spacing
Based on bending stress in post and insert
Load: 50 lbs per foot, applied horizontally at top rail

Calculations are for a dowel of similar material

| Post Material Pipe size | Post height (h) | 15" insert h1 = 9" | | 25" insert h1 = 12" h1 = 19" | |
|--------------------------------------------------|-----------------|-----------------------|------------|---------------------------------|----------|
| | | No insert | 15" insert | h1 = 12" | h1 = 19" |
| ● Aluminum 6063-T832 1 1/4" Sch. 10 | 30" | 38" | 55" | 64" | 90" |
| | 34" | 34" | 46" | 52" | 77" |
| | 38" | 30" | 40" | 44" | 61" |
| | 42" | 27" | 35" | 38" | 50" |
| ● Aluminum 6063-T832 1 1/4" Sch. 40 | 30" | 47" | 67" | 74" | 90" |
| | 34" | 41" | 56" | 64" | 79" |
| | 38" | 37" | 48" | 54" | 71" |
| | 42" | 33" | 42" | 47" | 61" |
| ● Aluminum 6063-T832 1 1/2" Sch. 10 | 30" | 52" | 74" | 86" | 134" |
| | 34" | 46" | 62" | 70" | 104" |
| | 38" | 41" | 53" | 60" | 82" |
| | 42" | 37" | 47" | 52" | 68" |
| ● Aluminum 6063-T832 1 1/2" Sch. 40 | 30" | 65" | 92" | 108" | 134" |
| | 34" | 57" | 78" | 88" | 118" |
| | 38" | 51" | 67" | 75" | 103" |
| | 42" | 46" | 59" | 65" | 85" |
| ● Bronze (Red Brass) C23000 1 1/4" Sch. 40 | 30" | 21" | 30" | 40" | 40" |
| | 34" | 18" | 25" | 35" | 35" |
| | 38" | 16" | 21" | 32" | 32" |
| | 42" | 15" | 19" | 27" | 27" |
| ● Bronze (Red Brass) C23000 1 1/2" Sch. 40 | 30" | 29" | 41" | 40" | 40" |
| | 34" | 25" | 34" | 35" | 35" |
| | 38" | 23" | 30" | 32" | 32" |
| | 42" | 21" | 26" | 27" | 27" |
| ● Stainless Steel Type 304 1 1/2" Sch. 5 | 30" | 40" | 100" | 120" | 120" |
| | 34" | 35" | 75" | 86" | 86" |
| | 38" | 32" | 60" | 67" | 67" |
| | 42" | 29" | 50" | 55" | 55" |
| ● Stainless Steel Type 304 1 1/2" Sch. 5 | 30" | 40" | 100" | 120" | 120" |
| | 34" | 35" | 75" | 86" | 86" |
| | 38" | 32" | 60" | 67" | 67" |
| | 42" | 29" | 50" | 55" | 55" |

Maximum Allowable Spans—Handrail
Based on bending stress in rail.
Load: 50 lbs per foot

| | 1 or 2 spans | 3 or more spans |
|-----------------------------|--------------|-----------------|
| ● Aluminum 6063-T52 | | |
| 1 1/4" Sch. 10 | 65" | 71" |
| 1 1/4" Sch. 40 | 71" | 78" |
| 1 1/2" Sch. 10 | 75" | 82" |
| 1 1/2" Sch. 40 | 84" | 92" |
| ● Bronze (Red Brass) C23000 | | |
| 1 1/4" Sch. 40 | 70" | 77" |
| 1 1/2" Sch. 40 | 83" | 90" |
| ● Stainless Steel Type 304 | | |
| 1 1/2" Sch. 5 | 98" | 107" |

If it is desired to use longer rail spans than allowed by the limits above, alloy 6063-T832 pipe should be used. Allowable rail span for 6063-T832 pipe is usually greater than allowable post spacing.

LOAD DISTRIBUTION CONSIDERATIONS

The graph below is used to determine railing load distribution. It has been determined by computer analysis and confirmed by laboratory test. The formula used in determining the graph assumes that all posts are of identical material and section.

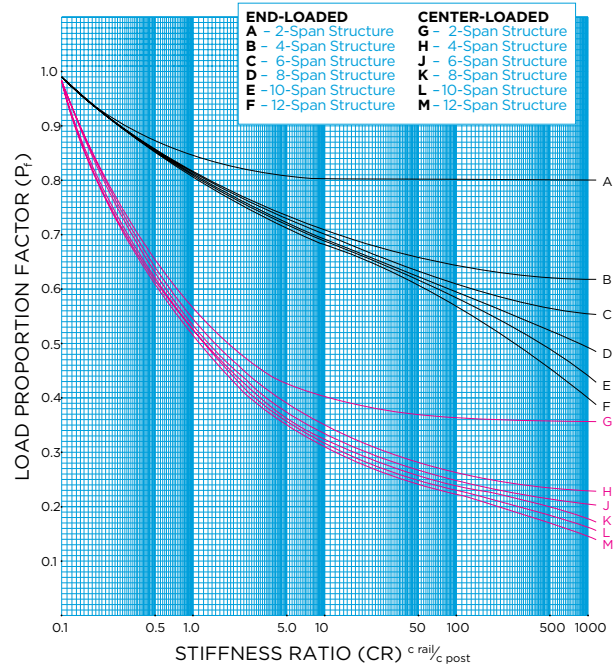

The Stiffness (C) of a rail or post is:

$$C_r = \frac{E \times I}{L} = \text{for the rail}$$

$$C_p = \frac{E \times I}{h} = \text{for the post}$$

(see page 122 for definition of symbols)

The Stiffness Ratio (CR) is determined as: $CR = \frac{C_r}{C_p}$

The Stiffness Ratio is then plotted on the graph to obtain a Load Proportion Factor (Pf). When the load proportion factor has been determined, it is multiplied by the total load to determine the load one post must sustain.

If one or both ends of the railing are free standing, the end-loaded condition must be assumed. If both ends of the run are laterally braced by a change in direction or attachment to a firm structure, the center-loaded load proportion factor may be used.

NOTE: If end posts differ from intermediate posts in strength, the load distribution pattern becomes indeterminate and end posts should then be designed to carry 100% of the concentrated load. Intermediate posts may then be designed to the center loaded condition.

In single span railings, each post must be designed to carry the full concentrated load. When posts and rails are of identical material and section (as in pipe railing), and post spacing varies between 3' and 6' feet while post height is between 30" and 42" inches, load distribution is fairly uniform. In this situation, the greatest proportion of a concentrated load carried by any post can be estimated as follows:

| | | | |
|-----------------|-----------|---------------------|-----------|
| End posts: | | Intermediate posts: | |
| 2-span railing | Pf = 0.85 | 2 span railing | Pf = 0.65 |
| 3 or more spans | Pf = 0.82 | 3 or more spans | Pf = 0.60 |

Thus, if a 200 lb concentrated load is specified for a pipe railing, actual design load to be applied at the top of the end post is .82 x 200 lb (164 lb), while design load to be applied to intermediate posts is .60 x 200 lb (120 lb). If railing posts are reinforced, the load proportion factor for posts is about 3 percentage points higher.

| ITEM # | PG# | | | | | | |
|----------|---------------------|----------|-----------------|------|-----------------|-------|--------------------|
| 3 | 54 | 142 | 24, 86, 95 | 214 | 28 | 273 | 52 |
| 4 | 54 | 142L | 44 | 215F | 29 | 274 | 52 |
| 11 | 54 | 143 | 24, 86, 95 | 216F | 29 | 275 | 13, 23, 89, 91 |
| 12 | 54 | 143L | 44 | 217 | 90 | 276 | 51 |
| 23L | 47 | 144 | 24, 86, 87, 95 | 218 | 23, 91 | 277 | 29 |
| 24L | 47 | 145 | 24, 86, 95 | 219 | 90 | 278 | 29 |
| 28L | 46 | 147 | 51 | 220 | 23, 91 | 279 | 78, 82 |
| 29 | 48 | 150CC | 41, 42 | 221 | 13, 23, 92 | 280 | 78, 79, 82, 123 |
| 29L | 46 | 150CL/CR | 41 | 222 | 22, 67, 89, 93 | 281 | 52 |
| 30 | 48 | 151 | 85, 89, 97 | 222L | 22 | 282 | 52 |
| 30L | 46 | 152 | 73, 86, 95 | 223 | 13, 23, 92 | 283 | 79, 123 |
| 33L | 46 | 153 | 49 | 224 | 12, 96 | 284 | 79 |
| 36L | 46 | 154 | 48 | 225 | 28 | 285 | 78 |
| 38 | 50 | 155 | 44 | 226 | 28 | 286 | 30 |
| 39 | 50 | 156 | 44 | 227 | 73, 75, 77, 79 | 287 | 30 |
| 40 | 50 | 157 | 44 | 228 | 79 | 288 | 30 |
| 43 | 50 | 158 | 49 | 229 | 79 | 289 | 30 |
| 44 | 50 | 159 | 49 | 230 | 78, 79, 82, 123 | 290 | 84, 89, 97, 103 |
| 47 | 50 | 160 | 84 | 231 | 79 | 291 | 30 |
| 48 | 50 | 161 | 73, 86, 95 | 232 | 28 | 292 | 30 |
| 51 | 50 | 162 | 73, 86, 95 | 233B | 79, 123 | 293 | 30 |
| 53 | 54 | 163 | 85, 89, 96, 103 | 234 | 47, 50 | 294 | 78, 123 |
| 54 | 54 | 164 | 85, 96, 103 | 235 | 47 | 295 | 78, 123 |
| 63 | 85, 96, 103 | 166 | 22, 84, 97 | 236 | 47 | 296 | 22, 84, 97, 103 |
| 64 | 85, 96, 103 | 167 | 84, 97 | 237 | 78 | 297 | 51 |
| 72 | 52 | 168 | 22, 84, 97 | 238 | 78, 82 | 298 | 22, 84, 97, 103 |
| 73 | 52 | 169 | 84, 97 | 239 | 47 | 299 | 84, 97, 103 |
| 74 | 52 | 170 | 13, 90 | 240 | 12, 96 | 300 | 50 |
| 75 | 50 | 171 | 69, 82, 93 | 241 | 82, 93 | 302 | 13, 90 |
| 77 | 50 | 172 | 69, 82, 93 | 242 | 13, 23, 92 | 304 | 13, 90 |
| 80 | 50 | 173 | 69, 83, 89, 92 | 243 | 13, 83, 92 | 305 | 90 |
| 100CC | 41, 42 | 174 | 69, 83, 92 | 245 | 82, 94 | 306 | 91 |
| 100CL/CR | 41 | 175 | 69, 83, 92 | 246 | 82, 94 | 307 | 13, 23, 83, 92, 94 |
| 100JL/JR | 40 | 176 | 13, 23, 91 | 247 | 83, 94 | 308 | 13, 23, 83, 92, 94 |
| 104 | 68 | 177 | 50 | 248 | 83, 94 | 309 | 34, 82, 89, 93 |
| 104-16 | 68 | 178 | 50 | 249 | 51 | 310 | 52 |
| 105 | 68 | 179 | 50 | 250 | 51 | 311 | 52 |
| 113 | 25, 35, 69, 87, 104 | 180 | 50 | 251 | 51 | 312 | 34, 82, 93 |
| 121L | 46 | 181 | 50 | 252 | 50 | 313 | 34, 83, 89, 92, 94 |
| 123 | 48 | 182 | 50 | 253 | 50 | 314 | 34, 83, 92, 94 |
| 123L | 47 | 183 | 45 | 254 | 50 | 315 | 90 |
| 124 | 48 | 184 | 45 | 255 | 51 | 316 | 23, 91 |
| 124L | 47 | 192 | 23, 91 | 256 | 51 | 317 | 90 |
| 125CC | 41, 42 | 193 | 90 | 257 | 51 | 318 | 23, 91 |
| 125CL/CR | 41 | 196 | 22, 84, 97, 103 | 258 | 28 | 319 | 13, 23, 91 |
| 126L | 46 | 198 | 45 | 259 | 28 | 321 | 13, 23, 89 |
| 128L | 46 | 201 | 51 | 260 | 50 | 322 | 22, 93 |
| 129 | 48 | 202 | 51 | 261 | 50 | 323 | 48 |
| 129L | 46 | 203 | 51 | 262 | 50 | 323L | 46 |
| 130 | 48 | 204 | 51 | 263 | 50 | 324 | 48 |
| 130L | 46 | 205 | 51 | 264 | 50 | 324L | 46 |
| 131 | 44 | 206 | 51 | 265 | 52 | 325 | 48 |
| 132 | 44 | 207 | 24, 86, 95 | 266 | 52 | 325DL | 46 |
| 134 | 44 | 208 | 24, 86, 95 | 267 | 50 | 325L | 46 |
| 135 | 44 | 209 | 44 | 268 | 50 | 326L | 44 |
| 136 | 44 | 210 | 28 | 269 | 50 | 327 | 48 |
| 137 | 48 | 211 | 11, 19, 28, 31 | 270 | 13, 90 | 327DL | 46 |
| 138 | 48 | 212 | 29 | 271 | 13, 83, 92 | 327L | 46 |
| 139 | 48 | 213 | 25, 69, 87, 104 | 272 | 52 | 328 | 48 |

| ITEM # | PG# | | | | | | |
|--------|------------|----------|------------------------------|----------|-------------------------|-------|--------|
| 328DL | 47 | 376 | 13, 23, 91 | 441 | 82, 85, 93, 96 | 526 | 62 |
| 328L | 47 | 377 | 90 | 442 | 82, 93 | 526-R | 54 |
| 329 | 48 | 378 | 91 | 443 | 13, 83, 92 | 527 | 62 |
| 329L | 46 | 381 | 90 | 444 | 13, 83, 92 | 528 | 49 |
| 330 | 48 | 382 | 90, 91 | 448 | 50 | 529 | 49 |
| 330L | 46 | 382-B | 91 | 449 | 51 | 530 | 49 |
| 331 | 44 | 382-W | 91 | 450CC | 41, 42 | 530D | 49 |
| 331L | 44 | 383 | 90 | 450CL/CR | 41 | 531 | 49 |
| 332 | 44 | 384 | 23, 91 | 451 | 77 | 531D | 49 |
| 332L | 44 | 385 | 90 | 452 | 50 | 532 | 49, 62 |
| 333 | 44 | 386 | 91 | 453 | 77 | 532D | 49 |
| 334 | 48 | 387 | 90 | 454 | 50 | 533 | 49 |
| 334L | 47 | 388 | 23, 91 | 455 | 51 | 533D | 49 |
| 335 | 48 | 389 | 13, 23, 91 | 456 | 51 | 534 | 49 |
| 336 | 48 | 390 | 51 | 457 | 51 | 535 | 57 |
| 336L | 47 | 391 | 51 | 458 | 74, 75, 76, 77, 82, 123 | 537 | 60 |
| 337 | 48 | 393 | 51 | 459 | 76, 77, 82, 123 | 538 | 60 |
| 337L | 47 | 395 | 51 | 461 | 50 | 539 | 60 |
| 338 | 48 | 396 | 51 | 462 | 69, 82, 94 | 540 | 60 |
| 338L | 47 | 397 | 51 | 463 | 69, 82, 94 | 541 | 60 |
| 339 | 48 | 398 | 51 | 464 | 69, 83, 94 | 542 | 59 |
| 339L | 47 | 399 | 51 | 465 | 69, 83, 94 | 543 | 57 |
| 340 | 44, 50 | 400 | 51 | 467 | 50 | 544 | 57 |
| 341 | 44, 50 | 400CC | 41, 42 | 468 | 75 | 545 | 57 |
| 342 | 51 | 400CL/CR | 41 | 469 | 75 | 546 | 57 |
| 343 | 44 | 401 | 38 | 473 | 52 | 547 | 57 |
| 343L | 44 | 402 | 22, 93 | 474 | 52 | 548 | 61 |
| 344 | 51 | 402L | 22, 93 | 477 | 90 | 550 | 63 |
| 345L | 44 | 403 | 13, 23 | 478 | 23, 89, 91 | 551 | 63 |
| 346 | 50 | 404 | 22, 93 | 479 | 50 | 552 | 63 |
| 347 | 51 | 405 | 13, 23 | 480 | 50 | 555 | 61 |
| 347L | 44 | 406 | 52 | 481 | 50 | 558 | 61 |
| 348 | 52 | 408 | 71, 81 | 482 | 50 | 559 | 57 |
| 349 | 51 | 411 | 11, 19, 28, 31 | 483 | 50 | 560 | 57 |
| 350 | 51 | 413 | 25, 69, 87, 104 | 484 | 50 | 561 | 57 |
| 351 | 51 | 414 | 83, 94 | 485 | 50 | 562 | 57 |
| 352 | 50 | 415 | 83, 94 | 486 | 50 | 563 | 57 |
| 353 | 50 | 418 | 83, 92 | 495 | 74 | 564 | 57 |
| 354 | 50, 51 | 419 | 83, 92 | 496 | 76 | 565 | 57 |
| 355 | 51 | 421 | 71 | 497 | 90 | 566 | 57 |
| 356 | 51 | 422 | 71 | 498 | 23, 91 | 567 | 57 |
| 357 | 51 | 423 | 70, 71, 123 | 504 | 59 | 568 | 63 |
| 358 | 48 | 424 | 70, 71, 80, 123 | 510 | 61 | 569 | 63 |
| 359 | 50 | 425 | 71 | 511 | 61 | 570 | 63 |
| 360 | 50 | 425CC | 41, 42 | 512 | 61 | 571 | 63 |
| 361 | 50 | 425CL/CR | 41 | 513 | 61 | 572 | 63 |
| 362 | 50 | 426 | 71 | 514 | 61 | 572-R | 54 |
| 363 | 50 | 427 | 70, 71, 123 | 515 | 61 | 573 | 63 |
| 365 | 52 | 428 | 73, 75, 77, 79 | 515B | 61 | 574 | 63 |
| 366 | 52 | 429 | 73, 75, 77 | 516 | 64 | 576 | 62 |
| 367 | 50 | 430 | 72, 73, 82, 86, 95, 123, 127 | 517 | 64 | 577 | 62 |
| 368 | 50 | 431 | 73 | 518 | 64 | 578 | 62 |
| 369 | 50 | 432 | 72, 74, 76, 82 | 519 | 64 | 579 | 58 |
| 370 | 13, 89, 90 | 433 | 73 | 520 | 62 | 580 | 62 |
| 371 | 13, 90 | 434 | 50 | 521 | 62 | 581 | 62 |
| 372 | 90 | 435 | 72 | 522 | 62 | 582 | 62 |
| 373 | 29, 91 | 436E | 72, 74, 76, 123 | 523 | 62 | 583 | 58 |
| 374 | 29, 91 | 439 | 82, 89, 93 | 524 | 62 | 584 | 64 |
| 375 | 13, 23, 91 | 440 | 82, 93 | 525 | 62 | 585 | 58 |

| ITEM # | PG# | | | | | | |
|----------|--------|------|--------------------|-----|---------------------|------|----------------|
| 586 | 63 | 708 | 17, 29 | 810 | 19, 28 | 928 | 28 |
| 587 | 63 | 709 | 44 | 811 | 11, 19, 28, 31 | 929 | 29 |
| 588 | 63 | 710 | 19, 28, 80, 87 | 813 | 25, 67, 69, 87, 104 | 930 | 29 |
| 589 | 59 | 711 | 11, 19, 28, 31, 80 | 824 | 12, 96 | 931 | 29 |
| 590 | 58 | 712 | 28 | 827 | 19 | 932 | 29 |
| 591 | 64 | 714 | 28 | 828 | 19 | 933 | 29 |
| 592 | 64 | 717 | 51 | 830 | 72, 73, 82, 123 | 934 | 29 |
| 593 | 64 | 718 | 48 | 831 | 73 | 936 | 30 |
| 594 | 64 | 719 | 51 | 833 | 73 | 937 | 30 |
| 595 | 64 | 720 | 28 | 835 | 72 | 938 | 30 |
| 596 | 57 | 723L | 46 | 838 | 73 | 939 | 30 |
| 597 | 57 | 724L | 46 | 839 | 73 | 942 | 28 |
| 598 | 57 | 727 | 19 | 840 | 12, 96 | 943 | 28 |
| 598-R | 54 | 728 | 19 | 841 | 82, 93 | 948 | 28 |
| 599 | 57 | 730L | 46 | 842 | 13, 23, 92 | 949 | 28 |
| 600CC | 41, 42 | 731L | 44 | 843 | 13, 83, 89, 92 | 951 | 30 |
| 600CL/CR | 41 | 733L | 46 | 844 | 13, 83, 92 | 952 | 30 |
| 601 | 30 | 735 | 47 | 862 | 82, 94 | 953 | 30 |
| 602 | 30 | 736L | 46 | 863 | 82, 94 | 954 | 30 |
| 604 | 29 | 738L | 46 | 864 | 83, 94 | 958 | 28 |
| 605 | 29 | 739L | 46 | 865 | 83, 94 | 959 | 28 |
| 606 | 30 | 740 | 47 | 866 | 52 | 960 | 59 |
| 607 | 30 | 746 | 20 | 872 | 52 | 961 | 58 |
| 608 | 30 | 747 | 20 | 883 | 45 | 962 | 59 |
| 609 | 30 | 748 | 19 | 884 | 45 | 963 | 57 |
| 610 | 28 | 749 | 19 | 887 | 45 | 964 | 57 |
| 611 | 28 | 750 | 19 | 888 | 45 | 965 | 57 |
| 612 | 28 | 752 | 50 | 890 | 84, 97, 103 | 967 | 57 |
| 614 | 28 | 753 | 50 | 891 | 90 | 968 | 57 |
| 615CC | 41, 42 | 754 | 50 | 892 | 23, 91 | 969 | 57 |
| 615CL/CR | 41 | 755 | 19 | 893 | 90 | 970 | 49 |
| 618 | 28 | 756 | 19 | 894 | 23, 91 | 971 | 49 |
| 619 | 28 | 757 | 19 | 896 | 22, 84, 89, 97, 103 | 972 | 49 |
| 620 | 28 | 758 | 19 | 898 | 22, 84, 97, 103 | 973 | 49 |
| 621 | 90 | 759 | 29 | 899 | 84, 97, 103 | 983 | 29 |
| 622 | 91 | 760 | 51 | 901 | 30 | 984 | 29 |
| 625 | 90 | 763 | 59 | 903 | 29 | 985 | 29 |
| 626 | 91 | 765 | 52 | 904 | 29 | 986 | 29 |
| 650CC | 41, 42 | 766 | 52 | 906 | 29 | 987 | 30 |
| 650CL/CR | 41 | 767 | 50 | 907 | 29 | 1021 | 90 |
| 664 | 29 | 768 | 50 | 908 | 29 | 1022 | 23, 91 |
| 665 | 29 | 769 | 50 | 909 | 29 | 1026 | 23, 91 |
| 682 | 48 | 773 | 70 | 910 | 29 | 1087 | 90 |
| 682L | 47 | 774 | 70, 80 | 911 | 28 | 1088 | 23, 91 |
| 683 | 48 | 775 | 80 | 912 | 28 | 1110 | 10, 31 |
| 683L | 47 | 776 | 51 | 913 | 28 | 1111 | 10, 11 |
| 684 | 48 | 777 | 70 | 914 | 28 | 1112 | 10, 11 |
| 684L | 47 | 782 | 21 | 915 | 28 | 1113 | 10, 11 |
| 686 | 44 | 783 | 21 | 917 | 28 | 1114 | 10, 11 |
| 687 | 44 | 784 | 21 | 918 | 28 | 1115 | 10, 11 |
| 690 | 51 | 786 | 20 | 919 | 28 | 1120 | 10, 31 |
| 691 | 51 | 787 | 20 | 920 | 28 | 1122 | 10, 31 |
| 694 | 51 | 788 | 20 | 921 | 30 | 1123 | 11, 31 |
| 695 | 51 | 797 | 51 | 922 | 30 | 1125 | 11, 31 |
| 701 | 30 | 801 | 13, 23, 92 | 923 | 30 | 1130 | 8, 10, 11, 123 |
| 702 | 30 | 802 | 22, 93 | 924 | 30 | 1132 | 8, 10, 123 |
| 703 | 44 | 803 | 13, 23, 92 | 925 | 28 | 1133 | 8, 35, 123 |
| 705 | 29 | 807 | 17, 29 | 926 | 28 | 1134 | 8, 35, 123 |
| 707 | 17, 29 | 808 | 17, 29 | 927 | 28 | 1135 | 8, 10, 11, 123 |

| ITEM # | PG# | | | | |
|-----------|----------------|-----------|--------------------|-----------|-----------------|
| 1136 | 8, 10, 123 | 1333N | 10, 31 | 1618 | 28 |
| 1137 | 8, 10 | 1334 | 37, 80, 119, 123 | 1619 | 28 |
| 1138 | 12 | 1334N | 37, 81 | 1622 | 89, 91 |
| 1139 | 12 | 1340 | 16 | 1624 | 12, 96 |
| 1141 | 6, 123 | 1341 | 82, 89, 93 | 1626 | 91 |
| 1142 | 6, 123 | 1342 | 13, 23, 92 | 1640 | 12, 96 |
| 1143 | 6, 123 | 1343 | 13, 83, 92 | 1653 | 54 |
| 1154 | 8, 10, 11, 123 | 1350CC | 41, 42 | 1654 | 54 |
| 1155 | 8, 10, 11, 123 | 1350CL/CR | 41 | 1664 | 29 |
| 1160 | 10, 11, 31 | 1361 | 22, 82, 94 | 1665 | 29 |
| 1161 | 12 | 1362 | 82, 94 | 1922 | 30 |
| 1162 | 12 | 1363 | 10, 11, 31 | 1923 | 30 |
| 1163 | 10, 11, 31 | 1364 | 83, 94 | 1961 | 58 |
| 1164 | 10, 11, 31 | 1365 | 83, 94 | 1962 | 59 |
| 1170 | 10, 11, 31 | 1366 | 82, 94 | 1963 | 59 |
| 1180 | 10, 31 | 1373 | 17 | 1970 | 49 |
| 1181 | 10, 31 | 1374 | 80 | 1971 | 49 |
| 1182 | 10, 31 | 1378 | 91 | 1972 | 49 |
| 1186 | 10 | 1382 | 91 | 1973 | 49 |
| 1201 | 51 | 1386 | 91 | 1983 | 45 |
| 1202 | 51 | 1410 | 10, 31 | 1984 | 45 |
| 1203 | 51 | 1411 | 10, 11 | 1988 | 45 |
| 1204 | 51 | 1413 | 10, 11 | 2003 | 65 |
| 1205 | 51 | 1414 | 10, 11 | 2012 | 65 |
| 1206 | 51 | 1420 | 10, 31 | 2014 | 65 |
| 1210 | 10, 31 | 1423 | 11, 31 | 2015 | 65 |
| 1211 | 10, 11 | 1425 | 11, 31 | 2016 | 65 |
| 1212 | 10, 11 | 1430 | 8, 10, 11, 123 | 2017 | 65 |
| 1213 | 10, 11 | 1432 | 8, 10, 11, 123 | 2023 | 65 |
| 1214 | 10, 11 | 1433 | 8, 10, 11, 123 | 2453 | 54 |
| 1220 | 10, 31 | 1452 | 8, 10, 11, 123 | 2454 | 54 |
| 1222 | 10, 31 | 1453 | 8, 10, 11, 123 | 2515 | 65 |
| 1223 | 11, 31 | 1463 | 10, 11, 31 | 2524 | 65 |
| 1225 | 11, 31 | 1464 | 10, 11, 31 | 2528 | 65 |
| 1230 | 9, 10, 11, 123 | 1472 | 8, 10, 11, 123 | 2538 | 65 |
| 1232 | 9, 10, 123 | 1473 | 8, 10, 11, 31, 123 | 2553 | 54 |
| 1233 | 9, 10, 11, 123 | 1473M | 10, 11 | 2554 | 54 |
| 1235 | 9, 10, 11, 123 | 1473N | 10, 31 | 2611 | 65 |
| 1264 | 10, 11, 31 | 1474 | 10, 31 | 2616 | 65 |
| 1280 | 10, 31 | 1480 | 10, 31 | 2640 | 65 |
| 1281 | 10, 31 | 1482 | 10, 31 | 2653 | 54 |
| 1282 | 10, 31 | 1504 | 59 | 2654 | 54 |
| 1283 | 10, 31 | 1508 | 58 | 2717 | 65 |
| 1302 | 22, 93 | 1531 | 49 | 2719 | 65 |
| 1303 | 13, 23, 92 | 1579 | 58 | 2726 | 65 |
| 1306 | 91 | 1583 | 58 | 2855 | 65 |
| 1315CC | 41, 42 | 1585 | 58 | 2859 | 65 |
| 1315CL/CR | 41 | 1589 | 59 | 2861 | 65 |
| 1323 | 11, 31 | 1601 | 54 | 2866 | 65 |
| 1325 | 11, 31 | 1603 | 54 | 2870 | 65 |
| 1328 | 19 | 1604 | 29 | 2932 | 65 |
| 1330 | 9, 10, 11, 123 | 1605 | 29 | 2982 | 65 |
| 1330C | 10, 16, 31 | 1606 | 30 | 3023 | 53 |
| 1330N | 10, 17, 31 | 1607 | 30 | 3024 | 53 |
| 1332 | 9, 10, 11, 123 | 1609 | 30 | 3025 | 53 |
| 1332C | 10, 31 | 1610 | 28 | 3033 | 53 |
| 1332N | 10, 31 | 1611 | 28 | 3034 | 53 |
| 1333 | 9, 10, 11, 123 | 1612 | 28 | 3041 | 53 |
| 1333C | 10, 31 | 1614 | 28 | 3042 | 53 |
| | | | | 3043 | 53 |
| | | | | 3044 | 53 |
| | | | | 3045 | 53 |
| | | | | 3064 | 53 |
| | | | | 3073 | 53 |
| | | | | 3123 | 53 |
| | | | | 3124 | 53 |
| | | | | 3125 | 53 |
| | | | | 3126 | 53 |
| | | | | 3133 | 53 |
| | | | | 3134 | 53 |
| | | | | 3142 | 53 |
| | | | | 3143 | 53 |
| | | | | 3144 | 53 |
| | | | | 3145 | 53 |
| | | | | 3164 | 94 |
| | | | | 3243 | 53 |
| | | | | 3277 | 53 |
| | | | | 3323 | 53 |
| | | | | 3523 | 53 |
| | | | | 3524 | 53 |
| | | | | 3525 | 53 |
| | | | | 3526 | 53 |
| | | | | 3541 | 53 |
| | | | | 3542 | 53 |
| | | | | 3543 | 53 |
| | | | | 3544 | 53 |
| | | | | 3545 | 53 |
| | | | | 3601 | 30 |
| | | | | 3602 | 30 |
| | | | | 3604 | 29 |
| | | | | 3605 | 29 |
| | | | | 3607 | 30 |
| | | | | 3608 | 30 |
| | | | | 4024 | 53 |
| | | | | 4416 | 38, 123 |
| | | | | 4428 | 38, 40, 42, 123 |
| | | | | 4428B | 38 |
| | | | | 4428C | 38, 41, 42 |
| | | | | 4428E | 38, 40 |
| | | | | 4428GL/GR | 38, 41 |
| | | | | 4428L | 38, 40 |
| | | | | 4428N | 38 |
| | | | | 4428S | 38 |
| | | | | 4428V | 38 |
| | | | | 4429 | 38, 40, 42, 123 |
| | | | | 4429B | 38 |
| | | | | 4429C | 38, 41, 42 |
| | | | | 4429E | 38, 40 |
| | | | | 4429F | 38, 40 |
| | | | | 4429F-3 | 40 |
| | | | | 4429F-4 | 40 |
| | | | | 4429F-5 | 40 |
| | | | | 4429F-6 | 40 |
| | | | | 4429GL/GR | 38, 41 |
| | | | | 4429JL/JR | 38 |
| | | | | 4429L | 38, 40 |
| | | | | 4429N | 38 |
| | | | | 4429S | 38 |

| ITEM # | PG# | | | | |
|-----------|-----------------------|-----------|----------------------|-----------|-------------------------------|
| 4429SL/SR | 38, 40 | 4534B | 36 | 4721 | 114 |
| 4429T | 38, 40 | 4534C | 36, 41, 42 | 4724 | 114 |
| 4429U | 38, 40 | 4534E | 36, 40 | 4730 | 114 |
| 4429UC | 38 | 4534GL/GR | 36, 41 | 4732 | 114 |
| 4429UL | 38 | 4534J | 36 | 4734 | 114 |
| 4429V | 38 | 4534L | 36, 40 | 4735 | 114 |
| 4435 | 38, 123 | 4534BN | 36 | 4736 | 114 |
| 4435V | 38 | 4534BS | 36 | 4744 | 114 |
| 4441 | 38, 40, 42, 123 | 4534T | 36, 40 | 4750 | 114 |
| 4441B | 38 | 4534V | 36 | 4752 | 114 |
| 4441C | 38, 41, 42 | 4535 | 36, 40, 42, 102, 123 | 4753 | 114 |
| 4441E | 38, 40 | 4535B | 36 | 4754 | 114 |
| 4441GL/GR | 38, 41 | 4535C | 41, 42 | 4759 | 114 |
| 4441N | 38 | 4535GL/GR | 36, 41 | 4760 | 114 |
| 4441S | 38 | 4535N | 36 | 4830 | 72, 73, 123 |
| 4441T | 38 | 4535S | 36 | 5120 | 55 |
| 4441U | 38, 40 | 4535T | 36, 40 | 5130 | 55 |
| 4441UC | 38 | 4535V | 36 | 5132 | 55 |
| 4441V | 38 | 4538 | 9, 10, 36, 42, 123 | 5140 | 55 |
| 4445 | 38 | 4538N | 36, 10 | 5142 | 55 |
| 4487 | 100 | 4539 | 36, 42, 102, 123 | 5143 | 55 |
| 4488 | 38, 42, 102, 121, 123 | 4539B | 36 | 5152 | 55 |
| 4488N | 38 | 4539C | 36, 41, 42 | 5153 | 55 |
| 4503 | 36, 102 | 4539GL/GR | 36, 41 | 5162 | 55 |
| 4506 | 25 | 4539N | 36 | 5163 | 55 |
| 4507 | 25 | 4539S | 36 | 5164 | 55 |
| 4519 | 100 | 4539V | 36 | 5183 | 55 |
| 4520 | 100 | 4551 | 99 | 5184 | 55 |
| 4522 | 100 | 4552 | 99 | 5235 | 37, 42, 102, 123 |
| 4523 | 100 | 4553 | 99 | 5235B | 37 |
| 4524 | 100 | 4553Q | 99 | 5235C | 37, 41, 42 |
| 4526 | 101 | 4555 | 99 | 5235GL/GR | 37, 41 |
| 4527 | 101 | 4556 | 99 | 5235N | 37 |
| 4529 | 36, 42, 123 | 4557 | 99 | 5235S | 37 |
| 4529N | 36 | 4558 | 99 | 5235V | 37 |
| 4530 | 36, 40, 42, 123, 127 | 4559 | 99 | 5264 | 22, 84, 97, 103 |
| 4530B | 36 | 4563 | 99 | 5274 | 37, 42, 102, 123 |
| 4530C | 36, 41, 42 | 4564 | 99 | 5274C | 37, 41, 42 |
| 4530E | 36, 40 | 4565 | 101 | 5274N | 37 |
| 4530GL/GR | 36, 41 | 4566 | 99 | 5288 | 37, 42, 102, 119, 123 |
| 4530J | 36 | 4569 | 99 | 5288N | 37 |
| 4530L | 36, 40 | 4572 | 36, 42, 123 | 5289 | 11, 31, 37, 42, 102, 119, 123 |
| 4530N | 36 | 4572C | 36, 41, 42 | 5289N | 37, 31 |
| 4530S | 36 | 4572N | 36 | 5320 | 55 |
| 4530T | 36, 40 | 4573 | 36, 42, 123 | 5325 | 55 |
| 4530V | 36 | 4573C | 36, 41, 42 | 5330 | 55 |
| 4531 | 36, 40, 42, 123 | 4573N | 36 | 5335 | 55 |
| 4531B | 36 | 4574 | 36, 42, 102, 123 | 5340 | 55 |
| 4531C | 36, 41, 42 | 4574C | 36, 41, 42 | 5364 | 22, 84, 97, 103 |
| 4531E | 36, 40 | 4574N | 36 | 5411 | 55 |
| 4531GL/GR | 36, 41 | 4575 | 36, 42, 102, 123 | 5415 | 55 |
| 4531J | 36 | 4575C | 36, 41, 42 | 5440 | 55 |
| 4531L | 36, 40 | 4575N | 36 | 5530 | 37, 42, 123 |
| 4531N | 36 | 4579 | 99 | 5530B | 37 |
| 4531S | 36 | 4589 | 99 | 5530C | 37, 41, 42 |
| 4531U | 36, 40 | 4590 | 100 | 5530GL/GR | 37, 41 |
| 4531V | 36 | 4596 | 100 | 5530N | 37 |
| 4533 | 9, 36, 123 | 4598 | 100 | 5530S | 37 |
| 4534 | 36, 40, 42, 123 | 4599 | 99 | 5530V | 37 |
| | | | | 5534 | 37, 42, 123 |
| | | | | 5534B | 37 |
| | | | | 5534C | 37, 41, 42 |
| | | | | 5534GL/GR | 37, 41 |
| | | | | 5534N | 37 |
| | | | | 5534S | 37 |
| | | | | 5534V | 37 |
| | | | | 5538 | 9, 10, 37, 42, 123 |
| | | | | 5538N | 37, 10 |
| | | | | 5563 | 99 |
| | | | | 5564 | 99 |
| | | | | 5569 | 99 |
| | | | | 5569X | 99 |
| | | | | 5572 | 37, 42, 123 |
| | | | | 5572C | 37, 41, 42 |
| | | | | 5572N | 37 |
| | | | | 5579 | 99 |
| | | | | 5589 | 99 |
| | | | | 5599 | 99 |
| | | | | 5615 | 55 |
| | | | | 5620 | 55 |
| | | | | 5625 | 55 |
| | | | | 5630 | 55 |
| | | | | 5632 | 55 |
| | | | | 5635 | 55 |
| | | | | 5640 | 55 |
| | | | | 5642 | 55 |
| | | | | 5643 | 55 |
| | | | | 5650 | 55 |
| | | | | 5652 | 55 |
| | | | | 5653 | 55 |
| | | | | 5660 | 55 |
| | | | | 5663 | 55 |
| | | | | 5664 | 55 |
| | | | | 5683 | 55 |
| | | | | 5684 | 55 |
| | | | | 5720 | 55 |
| | | | | 5730 | 55 |
| | | | | 5740 | 55 |
| | | | | 5784 | 55 |
| | | | | 5820 | 55 |
| | | | | 5830 | 55 |
| | | | | 5840 | 55 |
| | | | | 5863 | 55 |
| | | | | 5864 | 55 |
| | | | | 5883 | 55 |
| | | | | 5884 | 55 |
| | | | | 5920 | 55 |
| | | | | 5925 | 55 |
| | | | | 5930 | 55 |
| | | | | 5933 | 55 |
| | | | | 5935 | 55 |
| | | | | 5940 | 55 |
| | | | | 5943 | 55 |
| | | | | 5944 | 55 |
| | | | | 5963 | 55 |
| | | | | 6063-T52 | 31 |
| | | | | 6102 | 104 |
| | | | | 6105 | 104 |

| ITEM # | PG# | | | | |
|--------|------------------------------------|-----------|-----------------------------|-----------|----------------------|
| 6121 | 9, 105 | 6571 | 99 | 6931N | 34 |
| 6130 | 105 | 6572 | 99 | 6931S | 34 |
| 6140 | 105 | 6579 | 99 | 6931T | 34, 40 |
| 6201 | 54 | 6589 | 99 | 6931V | 34 |
| 6203 | 54 | 6599 | 99 | 6932 | 35, 42, 123, 126 |
| 6402 | 34, 42, 85, 97, 101, 123 | 6601 | 54 | 6932B | 35 |
| 6402C | 34 | 6603 | 54 | 6932C | 35, 41, 42 |
| 6402N | 34 | 6642 | 105 | 6932N | 35 |
| 6405 | 34, 42, 85, 97 | 6643 | 105 | 6932S | 35 |
| 6405C | 34 | 6645 | 105 | 6933 | 34, 42, 101, 123 |
| 6405N | 34 | 6646 | 105 | 6933B | 34 |
| 6407 | 34, 42, 85, 97, 123 | 6647 | 105 | 6933C | 34, 41, 42 |
| 6407C | 34 | 6901 | 34, 42, 123, 127 | 6933GL/GR | 34, 41 |
| 6407N | 34 | 6901C | 34, 41, 42 | 6933N | 34 |
| 6423 | 35, 70, 71, 112, 123 | 6901N | 34 | 6933S | 34 |
| 6424 | 35, 70, 71, 80, 112, 123 | 6902 | 34, 42, 123 | 6933V | 34 |
| 6427 | 70, 71, 123 | 6902C | 34, 41, 42 | 6934 | 34, 40, 42, 123 |
| 6430 | 72, 73, 85, 86, 95, 96, 123 | 6902N | 34 | 6934B | 34 |
| 6431 | 59 | 6903 | 35, 123 | 6934C | 34, 41, 42 |
| 6432 | 59 | 6904 | 35, 123 | 6934E | 34, 40 |
| 6433 | 59 | 6905 | 24, 34, 42, 85, 94, 96, 123 | 6934GL/GR | 34, 41 |
| 6434 | 35, 42, 70, 71, 80, 81, 112, 123 | 6905C | 34, 41, 42 | 6934L | 34, 40 |
| 6434C | 35, 42 | 6905N | 34 | 6934N | 34 |
| 6434N | 35, 81 | 6906 | 34, 42, 123 | 6934S | 34 |
| 6435 | 35, 42, 80, 82, 123 | 6906C | 34, 41, 42 | 6934T | 34, 40 |
| 6435C | 41, 42 | 6906N | 34 | 6934V | 34 |
| 6435N | 81 | 6907 | 34, 42, 123 | 6935 | 34, 40, 42, 101, 123 |
| 6436 | 35, 42, 123 | 6907C | 34, 41, 42 | 6935B | 34 |
| 6437 | 35, 42, 87, 101, 113, 123 | 6907N | 34 | 6935C | 34, 41, 42 |
| 6446 | 20 | 6910 | 100 | 6935E | 34, 40 |
| 6458 | 74, 75, 123 | 6913 | 101 | 6935GL/GR | 34, 41 |
| 6459 | 76, 77, 123 | 6914 | 100 | 6935N | 34 |
| 6473 | 105 | 6915 | 100 | 6935S | 34 |
| 6474 | 105 | 6916 | 100 | 6935T | 34, 40 |
| 6488 | 36, 42, 102, 117, 123 | 6921 | 100 | 6935V | 34 |
| 6489 | 11, 31, 36, 42, 102, 117, 123, 126 | 6922 | 100 | 6939 | 35, 101, 112, 123 |
| 6489C | 31, 41, 42 | 6923 | 100 | 6948 | 100 |
| 6489D | 31 | 6924 | 100 | 6952 | 104 |
| 6489N | 31 | 6925 | 100 | 6955 | 104 |
| 6501 | 38, 123 | 6926 | 100 | 6958 | 104, 111 |
| 6502 | 38, 12 | 6927 | 101 | 6959 | 104 |
| 6503 | 38, 102, 123 | 6929 | 34, 40, 42, 123 | 6960 | 104 |
| 6511 | 38, 42, 102, 123 | 6930 | 34, 35, 40, 42, 123 | 6961 | 101 |
| 6511N | 38 | 6930B | 34 | 6963 | 99 |
| 6512 | 38, 42, 102, 123 | 6930C | 34, 41, 42 | 6964 | 99 |
| 6512N | 38 | 6930E | 34, 40 | 6967 | 99 |
| 6513 | 38 | 6930GL/GR | 34, 41 | 6969 | 99 |
| 6513N | 38 | 6930J | 34 | 6970 | 99 |
| 6530 | 34, 42, 68, 123 | 6930L | 34, 40 | 6971 | 99 |
| 6530C | 34, 41, 42, 68 | 6930N | 34 | 6973 | 99 |
| 6530N | 34, 68 | 6930S | 34 | 6975 | 99 |
| 6531 | 34, 42, 68, 123 | 6930T | 40 | 6979 | 99 |
| 6531C | 34, 41, 42, 68 | 6930V | 34 | 6984 | 34, 42, 101, 123 |
| 6531N | 34, 68 | 6931 | 34, 40, 42, 123 | 6984C | 34, 41, 42 |
| 6532 | 34, 42, 67, 68, 123 | 6931B | 34 | 6984N | 34 |
| 6532C | 34, 41, 42, 68 | 6931C | 34, 41, 42 | 6985 | 34, 42, 101, 123 |
| 6532N | 34, 68 | 6931E | 34, 40 | 6985C | 34, 41, 42 |
| 6540 | 68, 123 | 6931GL/GR | 34, 41 | 6985N | 34 |
| 6569 | 99 | 6931L | 34, 40 | 6986 | 35, 101, 112, 123 |
| | | | | 6987 | 35, 42, 123 |
| | | | | 6987C | 35, 41, 42 |
| | | | | 6987N | 35 |
| | | | | 6988 | 35, 101, 112, 123 |
| | | | | 6989 | 99 |
| | | | | 6997 | 101 |
| | | | | 6998 | 100 |
| | | | | 6999 | 99 |
| | | | | 7063 | 11, 31 |
| | | | | 7103 | 16, 80 |
| | | | | 7104 | 16, 80 |
| | | | | 7109 | 18 |
| | | | | 7110 | 16 |
| | | | | 7111 | 18 |
| | | | | 7112 | 18 |
| | | | | 7115 | 18 |
| | | | | 7118 | 18 |
| | | | | 7119 | 18 |
| | | | | 7120 | 16 |
| | | | | 7122 | 18 |
| | | | | 7125 | 18 |
| | | | | 7128 | 18 |
| | | | | 7130 | 18 |
| | | | | 7139 | 18 |
| | | | | 7140 | 15, 16 |
| | | | | 7141 | 16 |
| | | | | 7142 | 18 |
| | | | | 7145 | 18 |
| | | | | 7148 | 18 |
| | | | | 7150 | 16 |
| | | | | 7160 | 25 |
| | | | | 7161 | 22, 25, 82, 94 |
| | | | | 7162 | 22, 80 |
| | | | | 7163 | 16 |
| | | | | 7164 | 22, 84, 97 |
| | | | | 7170 | 19 |
| | | | | 7173 | 18 |
| | | | | 7179 | 18 |
| | | | | 7180 | 17, 81 |
| | | | | 7181 | 17, 29 |
| | | | | 7182 | 18 |
| | | | | 7185 | 18 |
| | | | | 7188 | 18 |
| | | | | 7190 | 19 |
| | | | | 7191 | 19 |
| | | | | 7192 | 20, 128 |
| | | | | 7203 | 16, 80 |
| | | | | 7204 | 16, 80 |
| | | | | 7205 | 18 |
| | | | | 7206 | 18 |
| | | | | 7207 | 18 |
| | | | | 7208 | 18 |
| | | | | 7209 | 18 |
| | | | | 7210 | 10, 16, 31 |
| | | | | 7211 | 18 |
| | | | | 7212 | 18 |
| | | | | 7215 | 18 |
| | | | | 7216 | 18 |
| | | | | 7218 | 18 |

| ITEM # | PG# | | | | | | |
|--------|----------------|--------|---------|------|-----------------|-----------------------------------------|------------|
| 7219 | 18 | 7444 | 18 | 7585 | 18 | 9373 | 17 |
| 7220 | 16 | 7445 | 18 | 7588 | 18 | 9379 | 18 |
| 7222 | 18 | 7448 | 18 | 7592 | 20, 128 | 9380 | 10, 17, 31 |
| 7225 | 18 | 7450 | 16 | 7593 | 19 | 9382 | 18 |
| 7228 | 18 | 7451 | 18 | 7594 | 19 | 9385 | 18 |
| 7230 | 18 | 7460 | 25, 87 | 7595 | 20, 128 | 9388 | 18 |
| 7239 | 18 | 7460-5 | 25, 87 | 8106 | 25, 69, 104 | 9390 | 19 |
| 7240 | 16 | 7462 | 22, 80 | 8107 | 25, 69, 104 | 9391 | 19 |
| 7241 | 16 | 7463 | 16 | 8206 | 25, 69, 104 | 9392 | 20, 128 |
| 7242 | 18 | 7471 | 19 | 8207 | 25, 69, 104 | 9977 | 90 |
| 7243 | 18 | 7473 | 17 | 8610 | 16 | 56425 | 55 |
| 7244 | 18 | 7473-3 | 17 | 8640 | 16 | 56525 | 55 |
| 7245 | 18 | 7479 | 18 | 8661 | 22, 25, 82, 94 | | |
| 7248 | 18 | 7480 | 17, 81 | 8673 | 17 | | |
| 7250 | 16 | 7481 | 17, 29 | 8708 | 25, 69, 104 | | |
| 7260 | 25, 87 | 7482 | 18 | 8709 | 8 | | |
| 7261 | 22, 25, 82, 94 | 7485 | 18 | 8710 | 6 | | |
| 7262 | 22, 80 | 7488 | 18 | 8711 | 6 | | |
| 7263 | 16 | 7492 | 20, 128 | 8713 | 8 | | |
| 7264 | 22, 84, 97 | 7503 | 16, 80 | 8714 | 8 | | |
| 7270 | 19 | 7504 | 16, 80 | 8715 | 8 | | |
| 7271 | 19 | 7505 | 18 | 8716 | 8 | | |
| 7273 | 17 | 7506 | 18 | 8738 | 9 | | |
| 7279 | 18 | 7507 | 18 | 8810 | 16 | | |
| 7280 | 10, 17, 31, 81 | 7508 | 18 | 8840 | 16 | | |
| 7281 | 17, 29 | 7509 | 18 | 8861 | 22, 25, 82, 94 | | |
| 7282 | 18 | 7510 | 16 | 8864 | 22, 84, 97, 103 | | |
| 7285 | 18 | 7511 | 17 | 8873 | 17 | | |
| 7288 | 18 | 7512 | 18 | 8893 | 19 | | |
| 7290 | 19 | 7515 | 18 | 8894 | 19 | | |
| 7291 | 19 | 7516 | 18 | 8964 | 22, 84, 97, 103 | | |
| 7292 | 20, 128 | 7518 | 18 | 9161 | 22, 25, 82, 94 | | |
| 7293 | 19 | 7519 | 18 | 9164 | 22, 84, 97 | | |
| 7294 | 19 | 7520 | 16 | 9305 | 18 | | |
| 7295 | 20, 128 | 7522 | 18 | 9309 | 18 | | |
| 7403 | 16, 80 | 7525 | 18 | 9310 | 10, 16, 31 | | |
| 7404 | 16, 80 | 7528 | 18 | 9311 | 17 | | |
| 7405 | 18 | 7530 | 17 | 9312 | 18 | | |
| 7406 | 18 | 7539 | 18 | 9315 | 18 | | |
| 7407 | 18 | 7540 | 16 | 9316 | 18 | | |
| 7408 | 18 | 7541 | 16 | 9318 | 18 | | |
| 7409 | 18 | 7542 | 18 | 9319 | 18 | | |
| 7410 | 16 | 7543 | 17 | 9322 | 18 | | |
| 7411 | 17 | 7544 | 18 | 9325 | 18 | | |
| 7412 | 18 | 7545 | 18 | 9328 | 18 | | |
| 7415 | 18 | 7548 | 18 | 9330 | 17 | | |
| 7416 | 18 | 7550 | 16 | 9339 | 18 | | |
| 7418 | 18 | 7551 | 18 | 9340 | 16 | | |
| 7419 | 18 | 7560 | 25, 87 | 9341 | 16 | | |
| 7420 | 16 | 7560-5 | 25, 87 | 9342 | 18 | | |
| 7422 | 18 | 7562 | 22, 80 | 9344 | 18 | | |
| 7425 | 18 | 7563 | 16 | 9345 | 18 | | |
| 7428 | 18 | 7565 | 25 | 9348 | 18 | | |
| 7430 | 17 | 7571 | 19 | 9361 | 22, 25, 82, 94 | | |
| 7439 | 18 | 7573 | 17 | 9362 | 22 | | |
| 7440 | 16 | 7579 | 18 | 9363 | 10, 11, 16, 31 | | |
| 7441 | 16 | 7580 | 17, 81 | 9364 | 22, 84, 97, 103 | | |
| 7442 | 18 | 7581 | 17, 29 | 9371 | 19 | | |
| 7443 | 17 | 7582 | 18 | 9372 | 17 | | |
| | | | | | | 1/4"-20 x 1" SEMS | 16, 21 |
| | | | | | | 1/4"-20 x 2 1/2" RHMS | 21 |
| | | | | | | 1/4"-20 x 3" RHMS | 21 |
| | | | | | | 3/8" x 2" aluminum lag screw | 85, 94 |
| | | | | | | 3/8" x 2" brass lag screw | 45, 85, 94 |
| | | | | | | 3/8" x 2" stainless steel lag screw | 85, 94 |
| | | | | | | 3/8" x 2" nickel-silver lag screw | 45, 85, 94 |
| | | | | | | 3/8" x 3" steel hanger bolt | 85, 94 |
| | | | | | | 5/16" x 1 1/2" post bracket hanger bolt | 85, 94 |
| | | | | | | 3/8" x 3" sleeve anchor bolt | 21, 27 |
| | | | | | | A25-140 threaded rivet | 21 |
| | | | | | | A25-200 threaded rivet | 21 |
| | | | | | | Arc-Fit Pipe Notcher | 28 |
| | | | | | | Heavy-duty double machine bolt anchors | 85, 94 |
| | | | | | | Rivet heading tool | 21, 26 |
| | | | | | | Scotch-Weld® epoxy | 21, 26, 31 |



B

B

B

B



B

B

B

B

B



B

B

B

B



B

B

B

B

B



B

B

B

B



B

B

B

B

B



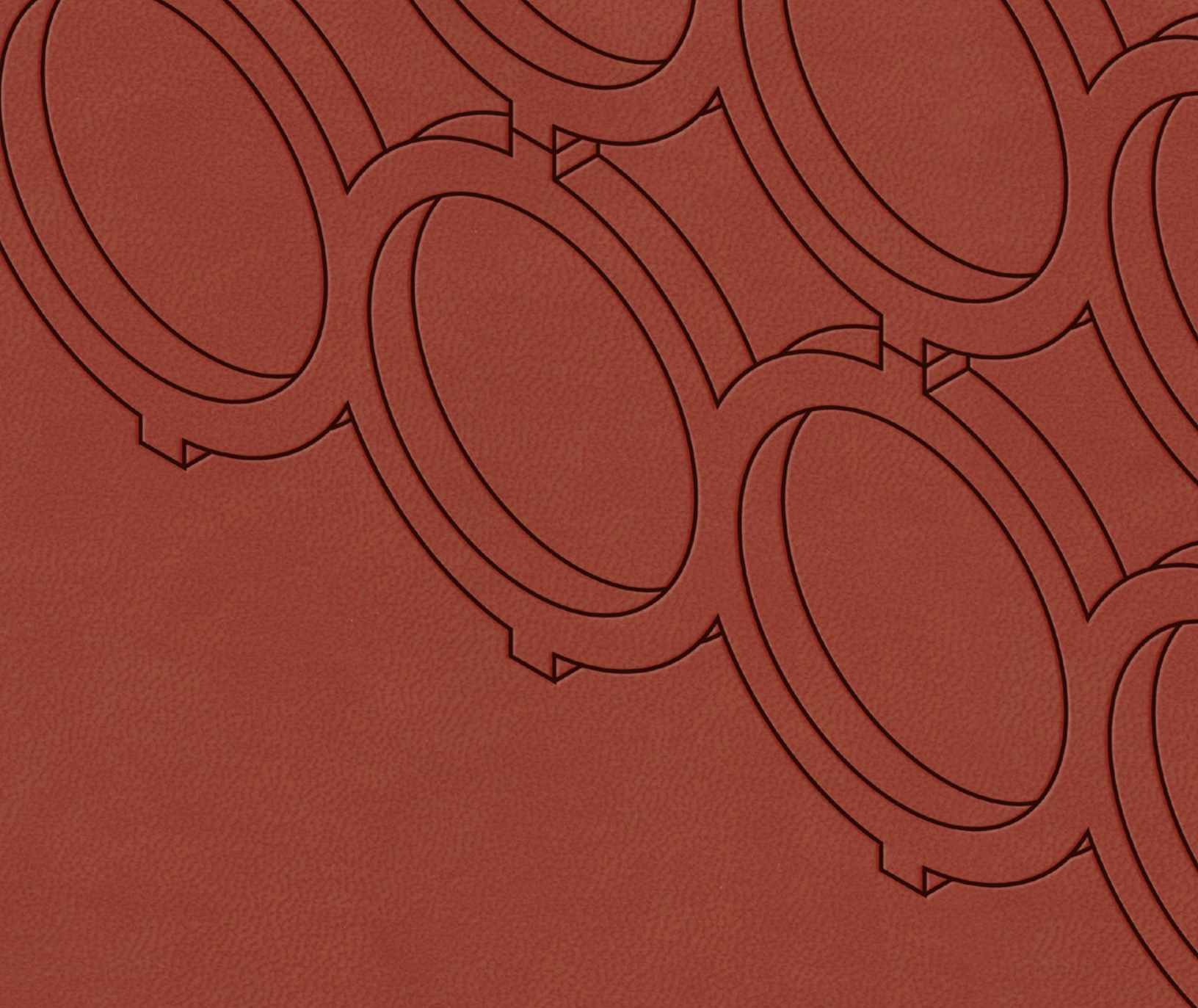

JULIUS BLUM & CO. INC.

Stock Components for Architectural Metal Work

Juliusblum.com
800.526.6293